



RUBY-D813-H610E-D5

Industrial Board

User Manual

Version R1.0

Copyright

The documentation and the software included with this product are copyrighted 2025 by Portwell. All rights are reserved. Portwell reserves the right to make improvements to the products described in this manual at any time without notice. No part of this manual may be reproduced, copied, translated, or transmitted in any form or by any means without the prior written permission of Portwell. The information provided in this manual is intended to be accurate and reliable. However, Portwell assumes no responsibility for its use, nor for any infringements of the rights of third parties that may result from its use.

Revision History

R1.0	Official release Rev. 1.0

Table of Contents

1. Introduction	5
2. Specifications	7
2.1 Supported Operating Systems	9
2.2 Mechanical Dimensions	10
2.3 Power Consumption	10
2.4 Environmental Specifications.....	11
3 Block Diagram	12
4 Hardware Configuration	14
4.1 Jumpers and Connectors.....	15
4.2 Jumper Settings	16
4.3 Connector Settings.....	18
5 Sample Code	27
5.1 Watch Dog Timer	28
5.2 GPIO Signal	30
6 BIOS Setup Items	45
6.1 Entering Setup -- Launch System Setup	46
6.2 Main.....	47
6.3 Advanced.....	48
6.3.1 PCH-FW Configuration	49
6.3.2 Trusted Computing.....	50
6.3.3 CPU Configuration	51
6.3.4 Graphics Configuration.....	52
6.3.5 PCI Express Configuration	56
6.3.6 CSM Configuration	57
6.3.7 Super I/O Configuration.....	64
6.3.8 Serial Console Redirection	67
6.3.9 SATA Configuration.....	75
6.3.10 Network Stack Configuration	78
6.3.11 USB Configuration.....	79
6.3.12 NVMe Configuration.....	80
6.3.13 Onboard Device Configuration.....	81
6.3.14 Miscellaneous	83
6.3.15 APM Configuration	84
6.3.16 EZ flash	86
6.3.17 Watchdog Timer.....	86
6.4 Hardware Monitor	48
6.5 Security	48
6.6 Boot.....	48
6.7	

6.7.8	EZ-Flash	88
6.3.1 G	Preserve BIOS option method	8G
7	System Resources.....	107
7.1	Intel PCH	107
7.2	Main Memory.....	107
7.3	Installing the Single Board Computer.....	107
8	Troubleshooting.....	110
8.1	Hardware Quick Installation.....	110
8.2	BIOS Setting.....	111
8.3	FAQ.....	113
G	Portwell Software Service.....	115

Chapter 1

Overview

1 Introduction

1. Introduction

The RUBY-D813-H610E-D5 supports Intel® Alder Lake/Raptor Lake/Raptor Lake Refresh -S Core™ i9 / i7 / i5 / i3, Pentium® and Celeron® Processors, LGA1700, utilizes the ATX form factor. It supports two DDR5 U-DIMMs up to 96GB capacity, one M.2 M key socket. Graphic with GfX Gen 12, HD graphics 730 /770, support four independent displays via DisplayPort, HDMI, and VGA. Additionally, it features two 1GbE ports, four USB3.2 ports and four USB 2.0 ports.

The RUBY-D813-H610E-D5 series is versatile, compact, powerful, making it ideal for diverse applications such as industrial automation, robotic control systems, automated test equipment, medical equipment, gateways, digital signage, and more.

Chapter 2

- 2 Specifications
- 2.1 Supported Operating Systems
- 2.2 Mechanical Dimension
- 2.3 Power Consumption

2. Specifications

Main Processor	Intel® Alder Lake/Raptor Lake/Raptor Lake Refresh -S Core™ i9 / i7 / i5 / i3,Pentium® and Celeron® Processors
Chipset	Intel® H610E Chipset
System BIOS	AMI UEFI BIOS
Main Memory	2x non-ECC DDR5 5600MT/s U-DIMM up to 96GB
Graphics	Controller: Intel® GfX Gen 12, HD graphics 730 /770 LVDS: Supports one LVDS up to resolution 1920 x 1200 DP: Supports one Display port up to resolution of 4096 x 2160 HDMI: Supports one HDMI port up to resolution of 4096 x 2160
Expansion Interface	1 x PCIe Gen5 x16 slot 1 x PCIe 3.0 x16 slot (x4 mode) 1 x PCIe 3.0 x1 slot 4 x PCI slots 1 x M.2 Socket 3 with M key, type 2242/2260/2280 (SATA/PCIe x1 mode)
SATA Interface	Four SATA ports(SATA 6Gb/s)
Input/Output	COM Ports: Six Ports _ 2x RS-232/422/485 on rear I/O &4x RS-232 on board header USB Port:4(2 x USB 3.2 Gen2, 2 x USB 3.2 Gen1) and 4x USB2.0 ports on REAR I/O, 1 x Header Support Additional 2 x USB2.0 Connectors Audio Interface: Line-In / Line-Out
Ethernet	Supports one 10/100/1000 Mbps Ethernet port (s) via PCI Express x1 bus Supports one 10/100/1000 Mbps Ethernet port (s) via PCI Express x1 bus
High Drive GPIO	One pin-header for GPIO(8bit GPIO)
Mechanical and environmental specifications	Operating temperature: 0 ~ 60° C Storage temperature:-20 ~ 80° C Humidity: 5 ~ 95% non-condensing Power supply voltage: ATX Board size: 304.8mm x 243.8 mm
Certification	CE/FCC

2.1 Supported Operating Systems

The RUBY-D813-H610E supports the following operating systems.

- Windows® 11 IoT Enterprise LTSC
- Windows® 10 (64bit)
- Windows® 10 IoT Enterprise
- Ubuntu
- RedHat Enterprise
- Fedora Workstation
- OpenSUSE

2.2 Mechanical Dimensions

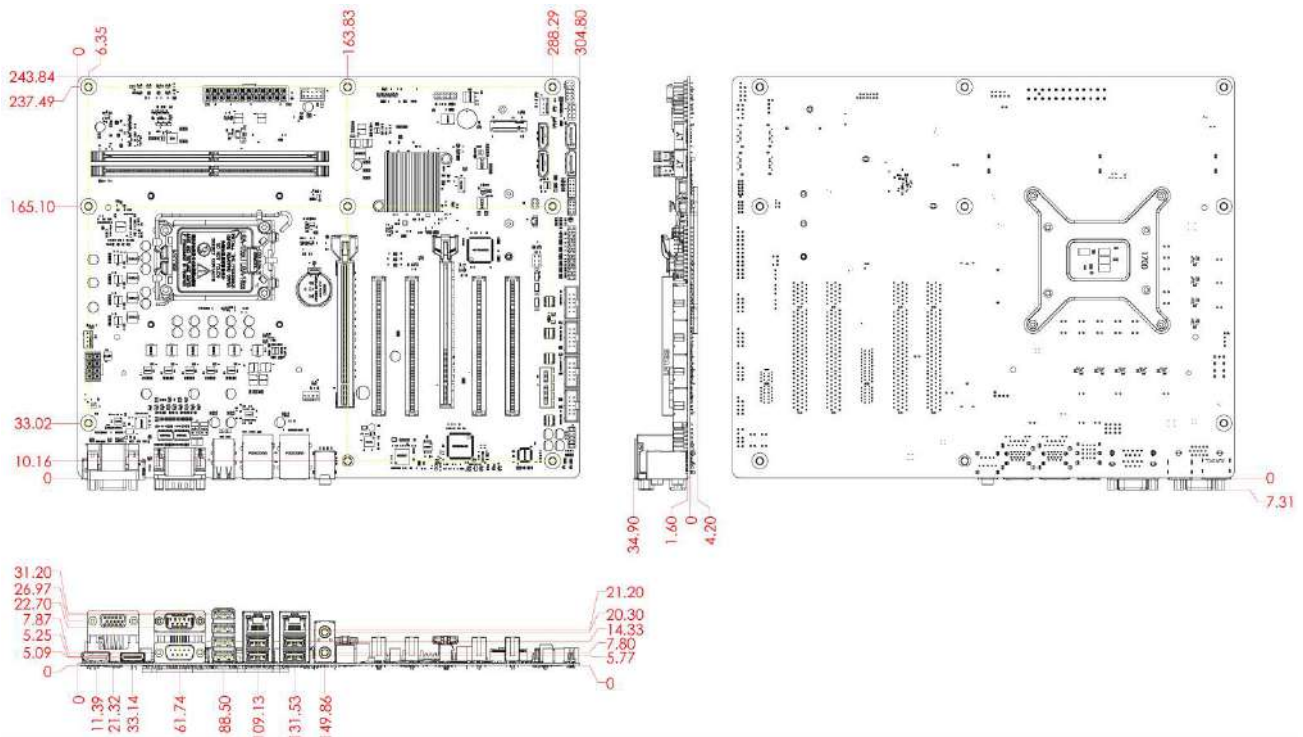

2.3 Power Consumption

CPU Type	Intel® Core™ i7-12700E CPU @ 4.8GHz
SBC BIOS	Portwell, Inc. RUBY-D813-H610EBIOS (1.00.00.02)
Memory	InnodiskDIMM DDR4 2666 16GB
VGA Card	Onboard Intel® UHD Graphics 770
VGA Driver	Intel® UHD Graphics 770 ver: 30.0.101.1371
LAN Card	Onboard Intel® Ethernet Connection I219V
LAN Driver	Intel® Ethernet Connection I219V Version: 12.19.1.37
LAN Card #2	Onboard Intel® I210AT Gigabit Network Connection
LAN Driver #2	Intel® I210AT Gigabit Network Connection Version: 12.18.12.1
Audio Card	Onboard Realtek ALC897 High Definition Audio
Audio Driver	Realtek ALC897 High Definition Audio Version: 6.0.9285.1
Chipset Driver	Intel® Alder lake-S Chipset Device Software Version: 10.1.18950.8298
USB 3.0 Driver	Intel® USB 3.0 eXtensible Host Controller Adaptation Driver
SATA HDD	Intel SSD 256G
Power Supply	FSP460-60PFB 460W

Power Consumption

Item	Power ON	Full Loading 10Min	Full Loading 30Min
CPU +12V	0.98A	2.05A	1.98A
System +12V	0.83A	1.48A	1.26A
System +3.3V	0.55A	0.65A	0.69A
System +5V	1.11A	1.37A	1.34A
System+ Device +12V	0.97A	1.81A	1.56A
System+ Device +5V	1.87A		
USB2.0 Loading Test	4.98 V/ 570 mA		

2.4 Environmental Specifications

Storage Temperature: -40~85° C

Operation Temperature: 0~60° C

Storage Humidity: 5~95%, non-condensing

Operation Humidity: 5~95%, non-condensing

Chapter 3

3 Block Diagram

RUBY-D814-Q870 user manual

3 Block Diagram

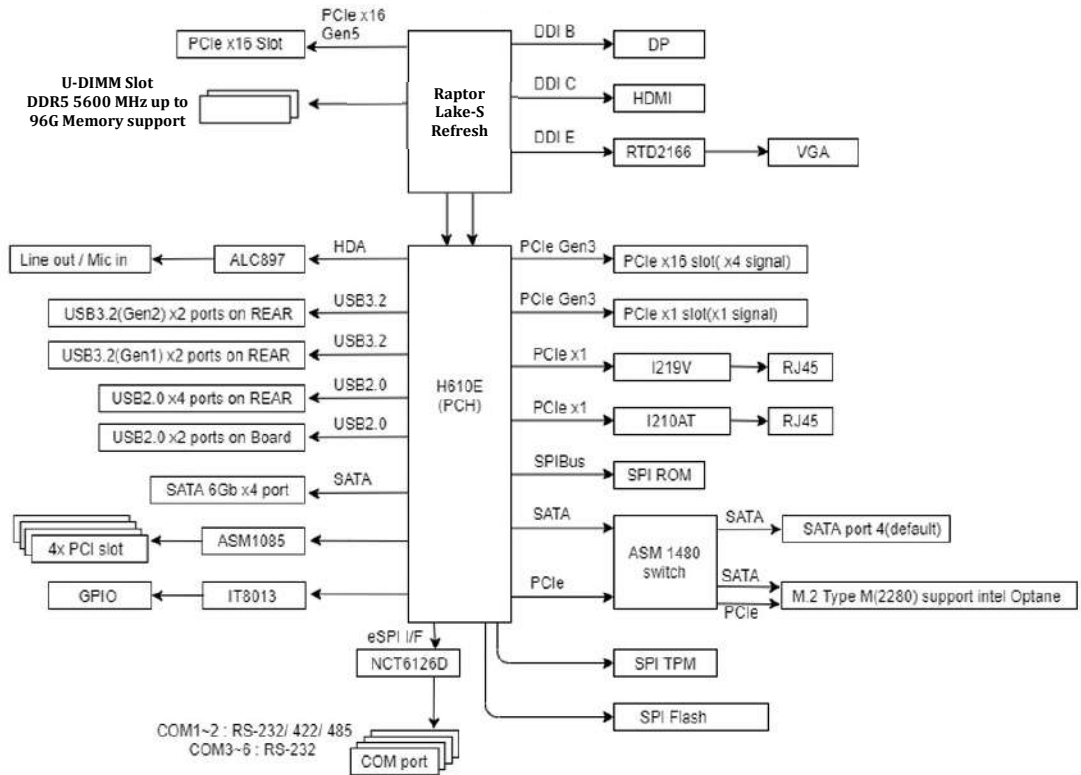

Chapter 4

- 4 Hardware Configuration
- 4.1 Jumpers and Connectors
- 4.2 Jumper Settings
- 4.3 Connector Settings

4 Hardware Configuration

4.1 Jumpers and Connectors

Figure 1, RUBY-D814-Q870 Top View

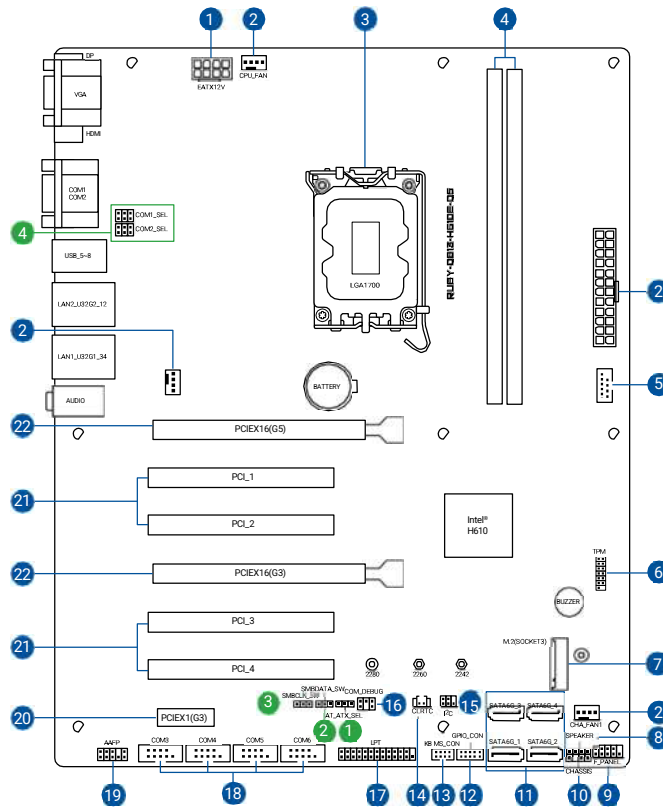

4.2 Jumper Settings

For users to customize RUBY-D813-H610E-D5's features. In the following sections, Short means covering a jumper cap over jumper pins; Open or N/C (Not Connected) means removing a jumper cap from jumper pins. Users can refer to Figure 1 for the Jumper allocations.

Jumper Table

The jumper settings are schematically depicted in this manual as follows:

Jump Function List:

Jump	Function	Remark
1	AT/ATX Mode selection jumper	2-pin
2	3-pin SMBDATA_SW	3-pin
3	3-pin SMBCLK_SW	3-pin
4	COM RING/+5V/+12V (COM1/2_SEL)	6-pin

1: AT/ATX Mode selection jumper (3-pin AT_ATX_SEL)

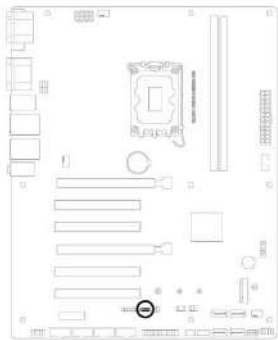

PIN No.	Signal Description
1-2 (default)	ATX ★
2-3	AT

2: 3-pin SMBDATA_SW

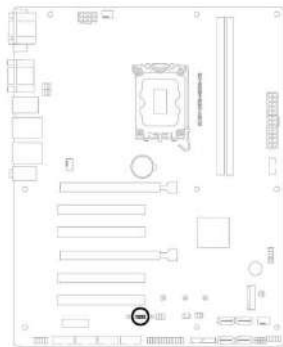

PIN No.	Signal Description
1-2	PCIe SMBus connection open
2-3 (default)	PCIe SMBus connection close

3: 3-pin SMBCLK_SW

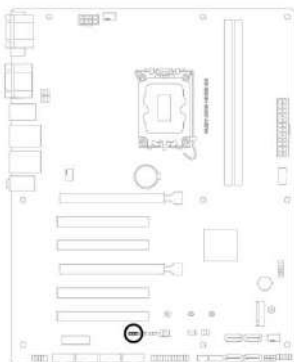

PIN No.	Signal Description
1-2	PCIe SMBCLK connection open
2-3 (default)	PCIe SMBCLK connection close

4: PANEL Voltage Selection

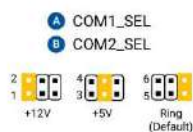
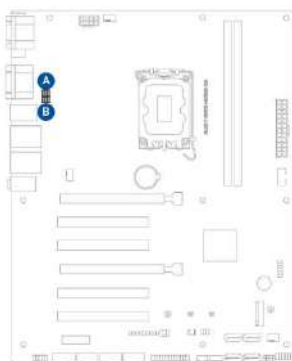

PIN No.	Signal Description
1-2	+12V
3-4	+5V
5-6 (default)	Ring

4.3 Connector Settings

Connector Function List:

Conn	Function	Remark
1	ATX Power connectors	24-pin, 2x4-pin
2	CPU and Chassis Fan headers	4-pin
3	Intel® LGA1700 CPU socket	
4	DDR5 U-DIMM slots	
5	USB 2.0 header	10-1 pin
6	TPM header	14-1 pin
7	M.2 socket (socket 3)	
8	Internal Speaker header	4-1 pin
9	System Panel header	10-1 pin
10	Chassis Intrusion header	4-1 pin
11	SATA 6.0 Gb/s connector	7-pin
12	GPIO header	6-1 pin
13	PS/2 Keyboard & Mouse header	8-pin
14	Clear RTC RAM	2- pin
15	I2C header	6-1 pin
16	COM Debug header	5-1 pin
17	LPT header	26-1 pin
18	COM Port headers (COM3 – COM6)	10-1 pin
19	Front Panel Audio header	10-1 pin
20	PCIe 3.0 x1 slot	
21	PCI slot	
22	PCIe 5.0/3.0 x16 slot	

1 ATX Power connectors (24-pin ATXPWR, 2x4-pin EATX12V)

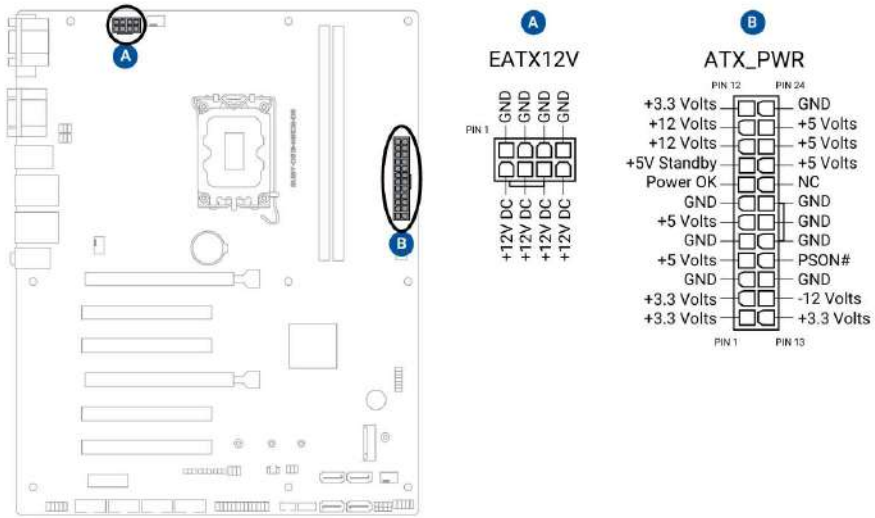

2 CPU and Chassis Fan headers (4-pin CPU_FAN, 4-pin CHA_FAN)

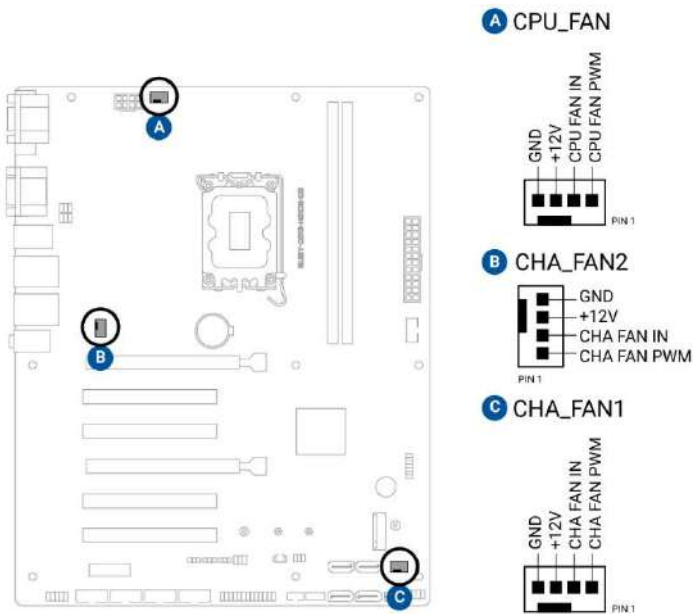

6 TPM header (14-1pin TPM)

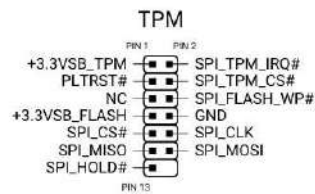
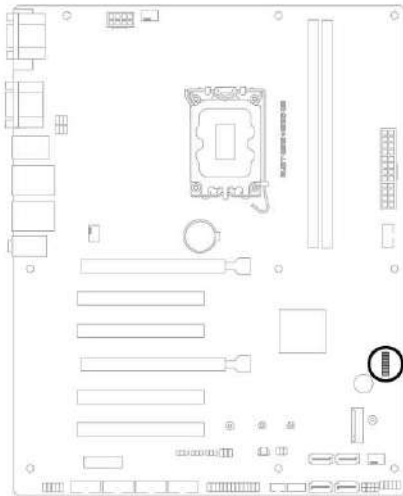

7 M.2 socket (socket 3)

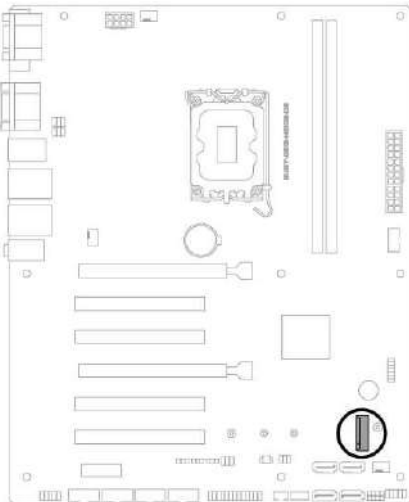

M.2(SOCKET3)

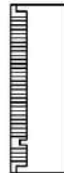

8 Internal Speaker header (4-pin SPEAKER)

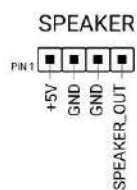
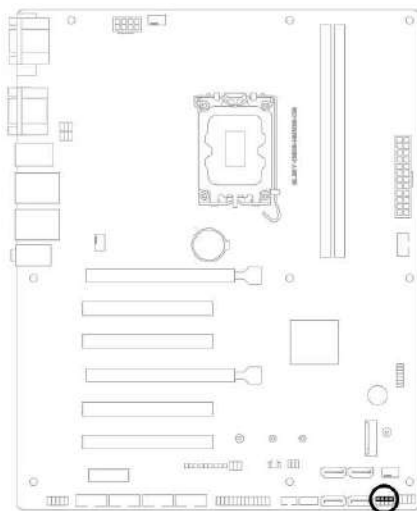

9 System Panel header (10-1 pin F_PANEL)

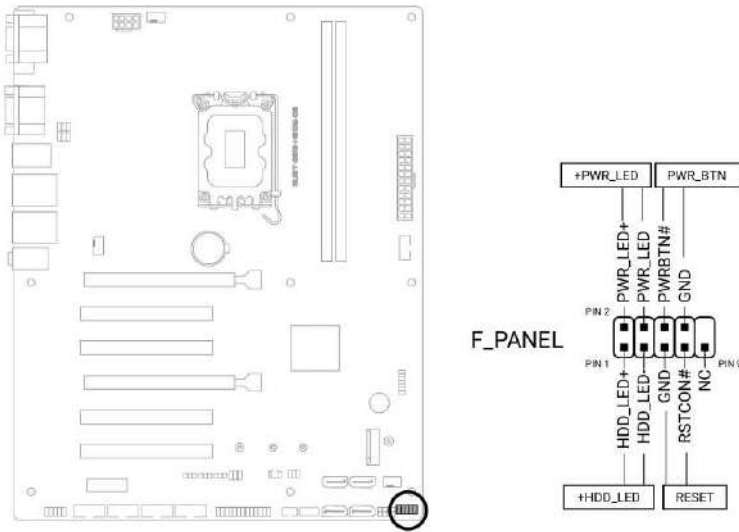

10 Chassis Intrusion header (4-1 pin CHASSIS)

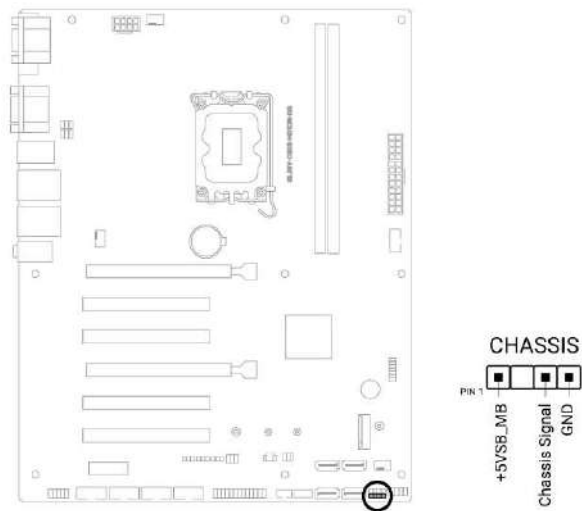

11 SATA 6.0 Gb/s connector (7-pin SATA6G_1-4)

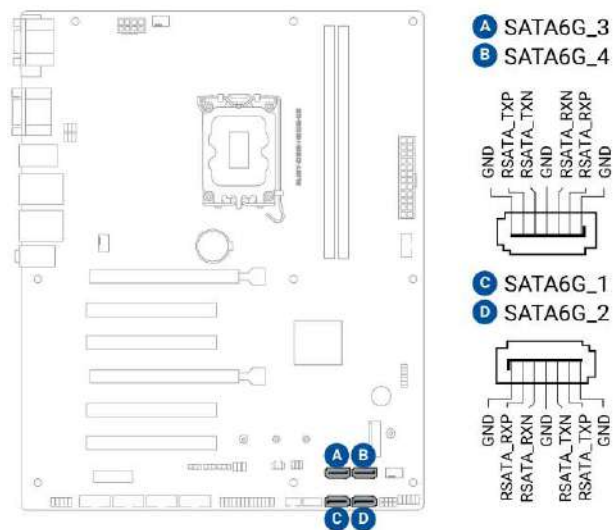

12 GPIO header (GPIO_CON)

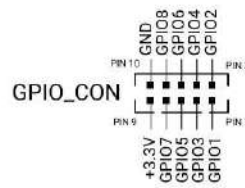
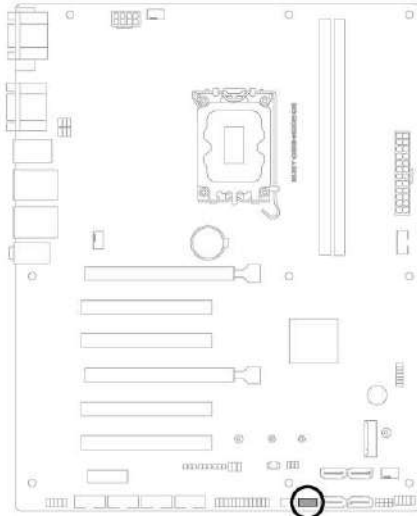

13 PS/2 Keyboard & Mouse header (8-pin KBMS_CON)

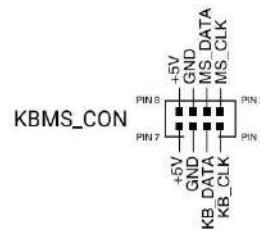
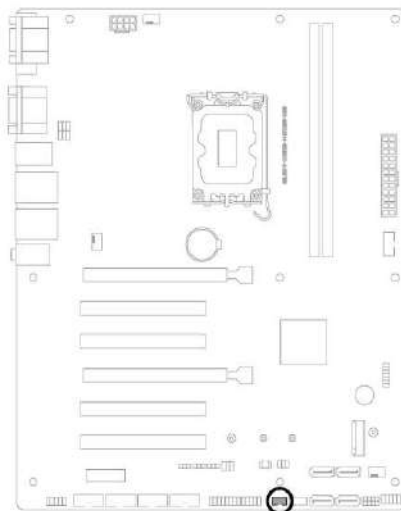

14 Clear RTC RAM (2-pin CLRRTC)

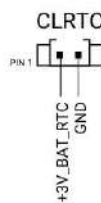
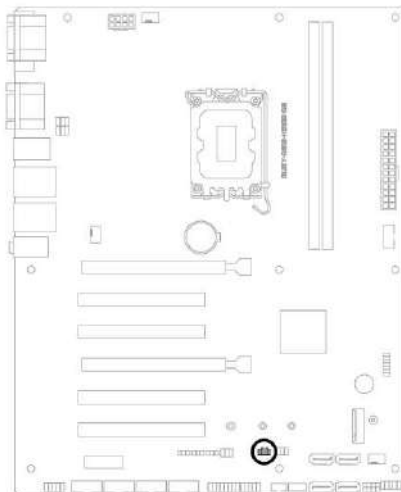

15 I2C header

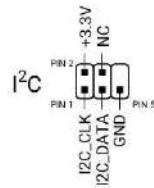
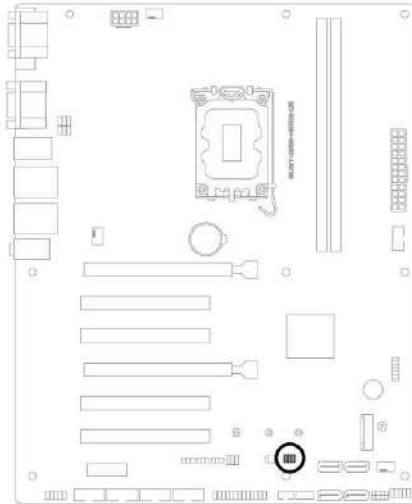

16 COM Debug header (5-1 pin COM_DEBUG)

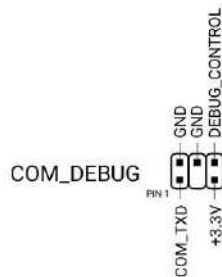
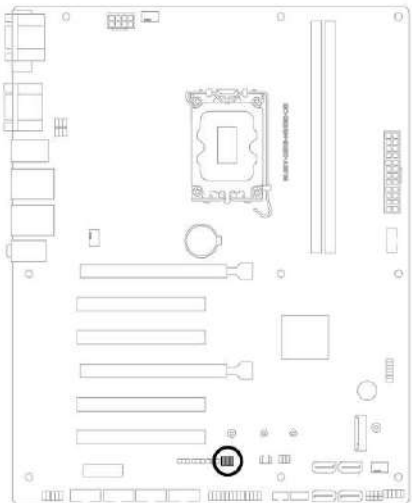

17 LPT header (26-1 pin LPT)

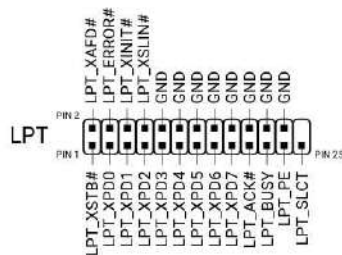
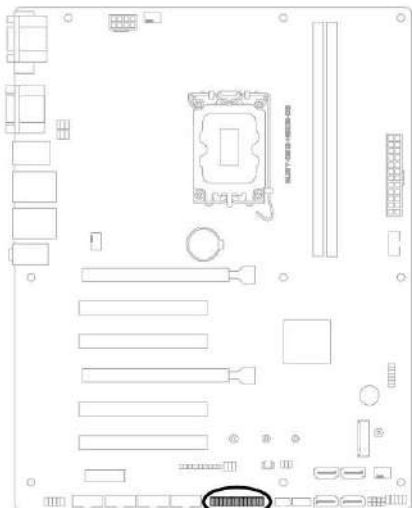

18 COM Port headers (10-pin COM3 – COM6)

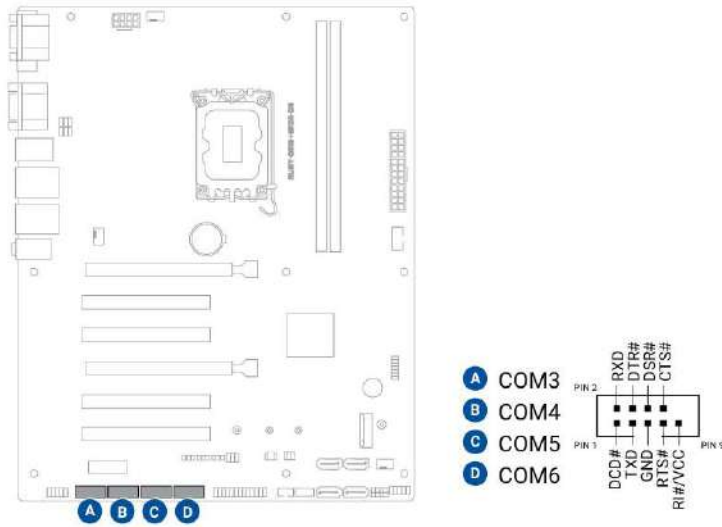

19 Front Panel Audio header (10-1 pin AAFP)

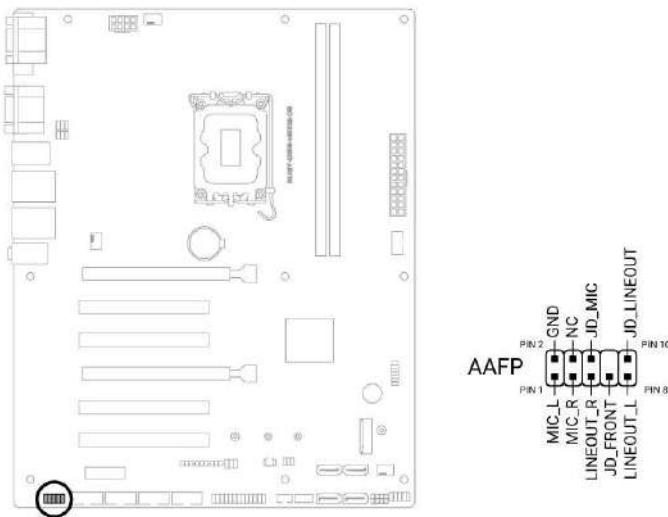

20 PCIe 3.0 x1 slot

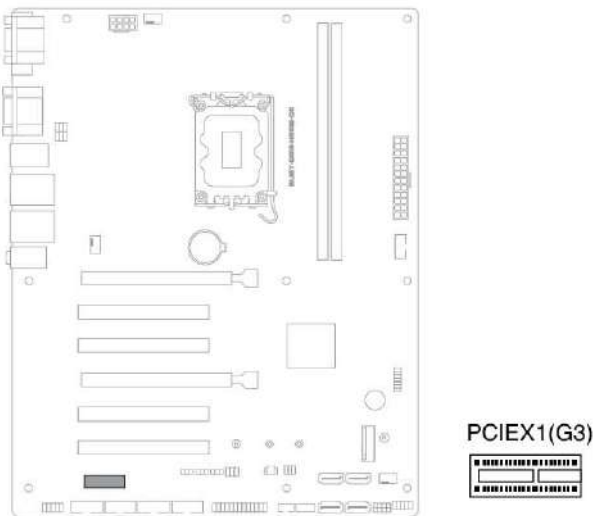

21 PCI slot

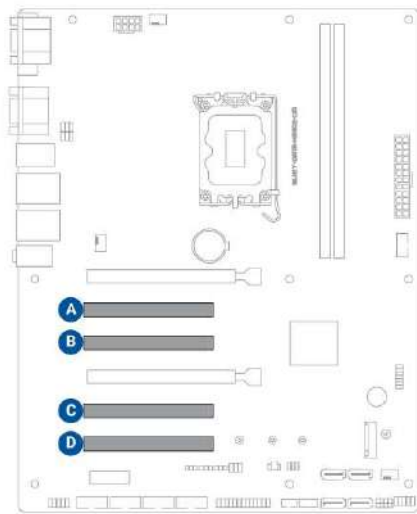

- A** PCL_1
- B** PCL_2
- C** PCL_3
- D** PCL_4



22 PCIe 5.0/3.0 x16 slot

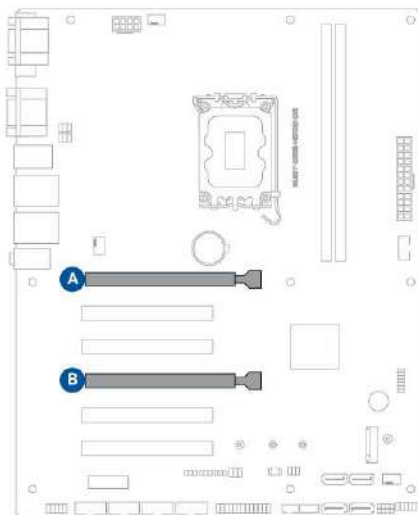

- A** PCIEX16(G5)
- B** PCIEX16(G3)

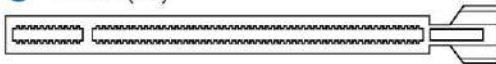

Chapter 5

Overview

- 5 Sample Code
- 5.1 Watch Dog Signal
- 5.2 Signal GPIO Signal

5 Sample Code

5.1 Watch Dog Signal

WDT setting

SIO_INDEX_PORT is 0x2E SIO_DATA_PORT is 0x2F

1. Set WDT Time Unit

```
Outportb(SIO_INDEX_PORT, 0x87); // Unlock SIO Outportb(SIO_INDEX_PORT, 0x87); // Unlock SIO
```

```
Outportb(SIO_INDEX_PORT, 0x07); Outportb(SIO_DATA_PORT, 0x08);
```

```
Outportb(SIO_INDEX_PORT, 0xF0); //select WDT setting
```

```
val = Inportb(SIO_DATA_PORT) // Read current WDT setting
```

```
val = val | 0x08; // minute mode, val = val & 0xF7 if second mode Outportb(SIO_INDEX_PORT, 0xF0); //select WDT setting Outportb(SIO_DATA_PORT, val); // Write back WDT setting
```

```
Outportb(SIO_INDEX_PORT, 0xAA); // Lock SIO
```

2. Set WDT Time

```
Outportb(SIO_INDEX_PORT, 0x87); // Unlock SIO Outportb(SIO_INDEX_PORT, 0x87); // Unlock SIO
```

```
Outportb(SIO_INDEX_PORT, 0x07); Outportb(SIO_DATA_PORT, 0x08);
```

```
Outportb(SIO_INDEX_PORT, 0xF1); //select time value
```

```
Outportb(SIO_DATA_PORT, Time); // Write WDT time, value 1 to 255
```

```
Outportb(SIO_INDEX_PORT, 0xAA); // Lock SIO
```

3. Enable WDT

```
Outportb(SIO_INDEX_PORT, 0x87); // Unlock SIO Outportb(SIO_INDEX_PORT, 0x87); // Unlock SIO
```

```
Outportb(SIO_INDEX_PORT, 0x07); // select device Outportb(SIO_DATA_PORT, 0x08); // device 8 Outportb(SIO_INDEX_PORT, 0x30); //select WDT status port val = Inportb(SIO_DATA_PORT) // Read current WDT status
```

```
val = val | 0x01; // Enable WDT Timer
```

```
Outportb(SIO_INDEX_PORT, 0x30); //select WDT status port Outportb(SIO_DATA_PORT, val); // Write back WDT status
```

```
Outportb(SIO_INDEX_PORT, 0xAA); // Lock SIO
```

4. Disable WDT

```
Outportb(SIO_INDEX_PORT, 0x87); // Unlock SIO Outportb(SIO_INDEX_PORT, 0x87); // Unlock SIO
```

```
Outportb(SIO_INDEX_PORT, 0x07); Outportb(SIO_DATA_PORT, 0x08); Outportb(SIO_INDEX_PORT, 0xF1); //select time value Outportb(SIO_DATA_PORT, 0x00); // Clear WDT time, it means WDT Time-Out disable Outportb(SIO_INDEX_PORT, 0x30); //select WDT status port
```

```
val = Inportb(SIO_DATA_PORT) // Read current WDT status val = val & 0xFE; // Disable WDT Timer Outportb(SIO_INDEX_PORT, 0x30); //select WDT status port Outportb(SIO_DATA_PORT, val); // Write back WDT status
```

```
Outportb(SIO_INDEX_PORT, 0xAA); // Lock SIO
```

5. RUBY-D813-H610E SIO not support WDT Reset Flag judgement.

5.2 GPIO Signal

GPIO Setting

SIO_INDEX_PORT is 0x2E SIO_DATA_PORT is 0x2F

```
Set GPIOn to GPI or GPO Outportb(SIO_INDEX_PORT, 0x87); // Unlock SIO
Outportb(SIO_INDEX_PORT, 0x87); // Unlock SIO
```

```
Outportb(SIO_INDEX_PORT, 0x07); Outportb(SIO_DATA_PORT, 0x07);
```

```
Outportb(SIO_INDEX_PORT, 0x30); val = Inportb(SIO_DATA_PORT)
val = val | 0x10; Outportb(SIO_INDEX_PORT, 0x30);
Outportb(SIO_DATA_PORT, val); // Active GPIO
```

```
Outportb(SIO_INDEX_PORT, 0xF0);
val = Inportb(SIO_DATA_PORT) // Read current value
val = val | (0x01 << GPIOn); // GPO, val = val & ~(0x01 << GPIOn); if GPI, GPIOn is value 0 to 7
```

```
Outportb(SIO_INDEX_PORT, 0xF0); Outportb(SIO_DATA_PORT, val);
```

```
Outportb(SIO_INDEX_PORT, 0xAA); // Lock SIO
```

```
Get GPIOn GPI value Outportb(SIO_INDEX_PORT, 0x87); // Unlock SIO
Outportb(SIO_INDEX_PORT, 0x87); // Unlock SIO
```

```
Outportb(SIO_INDEX_PORT, 0x07); Outportb(SIO_DATA_PORT, 0x07);
```

```
Outportb(SIO_INDEX_PORT, 0x30); val = Inportb(SIO_DATA_PORT)
val = val | 0x10; Outportb(SIO_INDEX_PORT, 0x30);
Outportb(SIO_DATA_PORT, val); // Active GPIO
```

```
Outportb(SIO_INDEX_PORT, 0xF1);
val = Inportb(SIO_DATA_PORT) // Read current value Outportb(SIO_INDEX_PORT, 0xAA); //
Lock SIO
```

```
if (val & (0x01 << GPIO_n)) // Determine if GPIO_n is High or Low; GPIO_n is value 0 to 7
```

```
else
```

```
return HIGH; //GPI High return LOW; //GPI Low
```

```
Set GPIO_n GPO value Outportb(SIO_INDEX_PORT, 0x87); // Unlock SIO
```

```
Outportb(SIO_INDEX_PORT, 0x87); // Unlock SIO
```

```
Outportb(SIO_INDEX_PORT, 0x07); Outportb(SIO_DATA_PORT, 0x07);
```

```
Outportb(SIO_INDEX_PORT, 0x30); val = Inportb(SIO_DATA_PORT)
```

```
val = val | 0x10; Outportb(SIO_INDEX_PORT, 0x30);
```

```
Outportb(SIO_DATA_PORT, val); // Active GPIO
```

```
Outportb(SIO_INDEX_PORT, 0xF1);
```

```
val = Inportb(SIO_DATA_PORT) // Read current value
```

```
val = val | (0x01 << GPIO_n); // GPO LOW, val = val & ~(0x01 << GPIO_n); if GPO High, GPIO_n is  
value 0 to 7 Outportb(SIO_INDEX_PORT, 0xF1);
```

```
Outportb(SIO_DATA_PORT, val); Outportb(SIO_INDEX_PORT, 0xAA); // Lock SIO
```

Chapter 6

- 6 BIOS Setup Items
- 6.1 Entering Setup -- Launch System Setup
- 6.2 Main
- 6.3 Configuration

6 BIOS Setup Items

The following section describes the BIOS setup program. The BIOS setup program can be used to view and change the BIOS settings for the module. Only experienced users should change the default BIOS settings.

6.1 Entering Setup -- Launch System Setup

Power on the computer and the system will start POST (Power On Self Test) process. When the message below appears on the screen, press key will enter BIOS setup screen.

Press to enter SETUP

If the message disappears before responding and still wish to enter Setup, please restart the system by turning it OFF and On or pressing the RESET button. It can be also restarted by pressing <Ctrl>, <Alt>, and <Delete> keys on keyboard simultaneously.

Press <F1> to Run General Help or Resume

The BIOS setup program provides a General Help screen. The menu can be easily called up from any menu by pressing <F1>. The Help screen lists all the possible keys to use and the selections for the highlighted item. Press <Esc> to exit the Help screen.

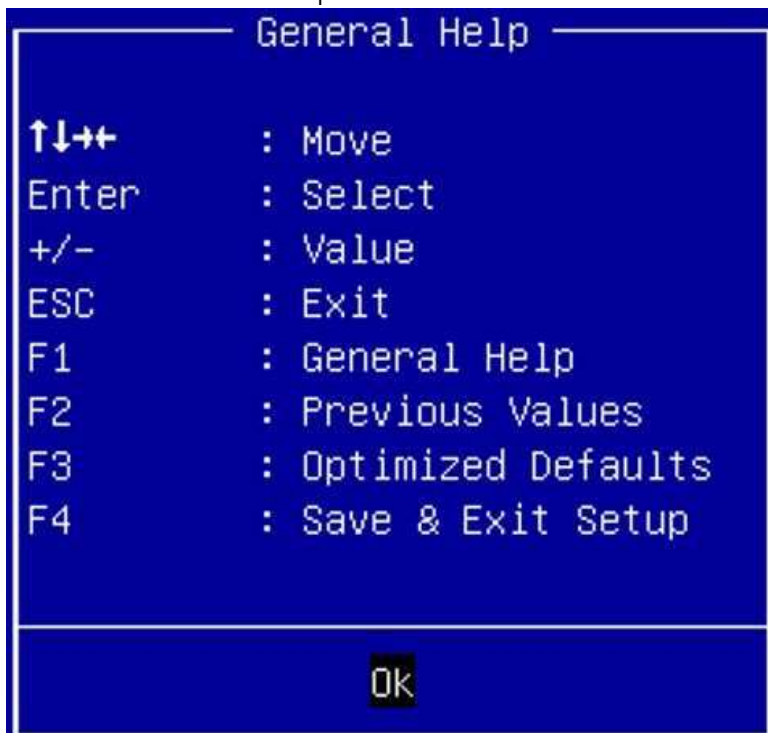

6.2 Main

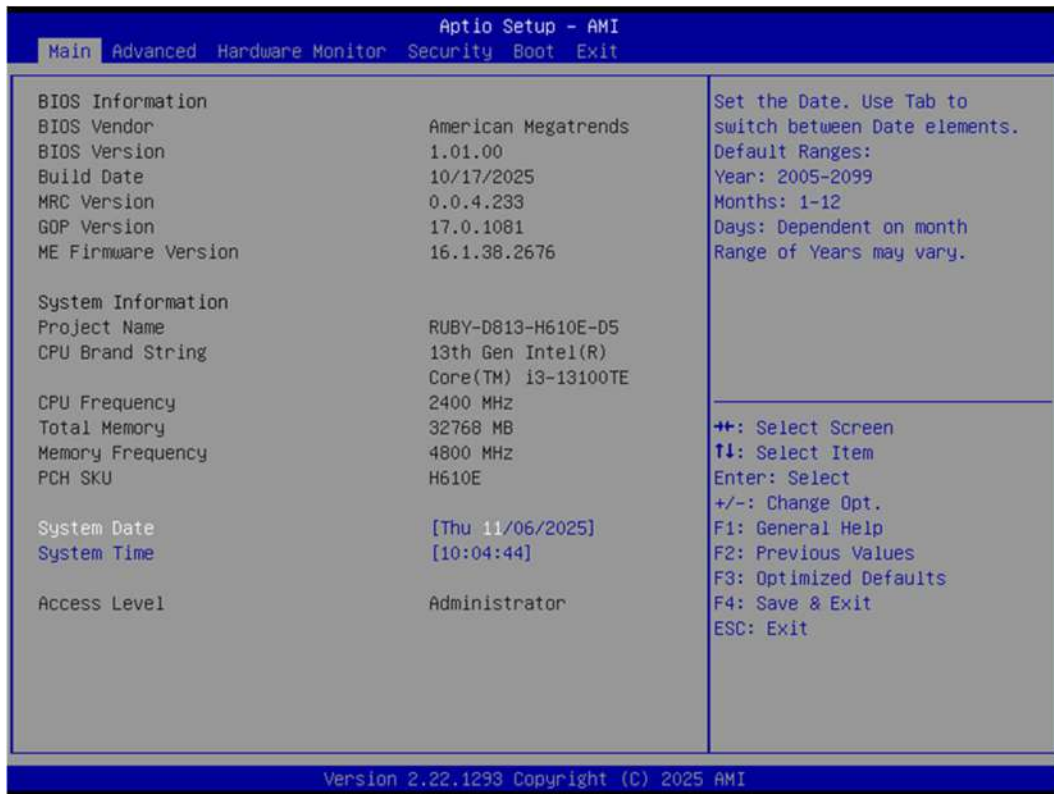

Feature	Description	Options
System Date	Set the Date. Use Tab to switch between Date elements. Default Ranges: Year: 2005 – 2099 Months: 1 – 12 Days: Dependent on month Range of Years may vary.	
System Time	Set the Time. Use Tab to switch between Time elements.	

6.3 Advanced

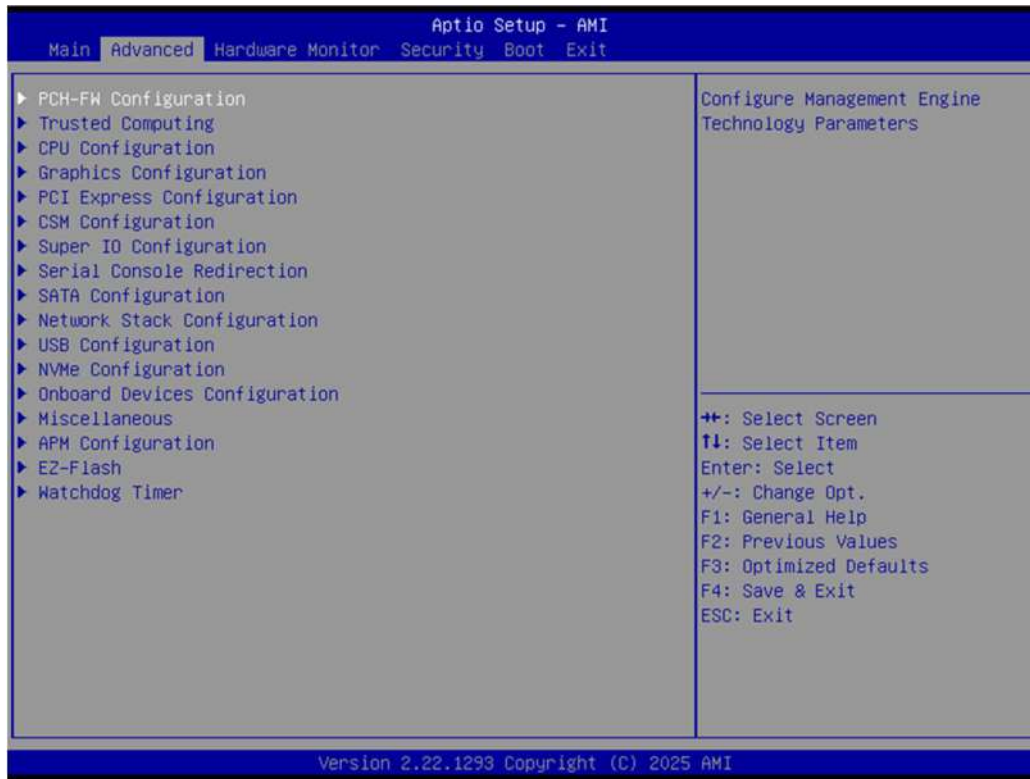

6.3.1 PCH-FW Configuration

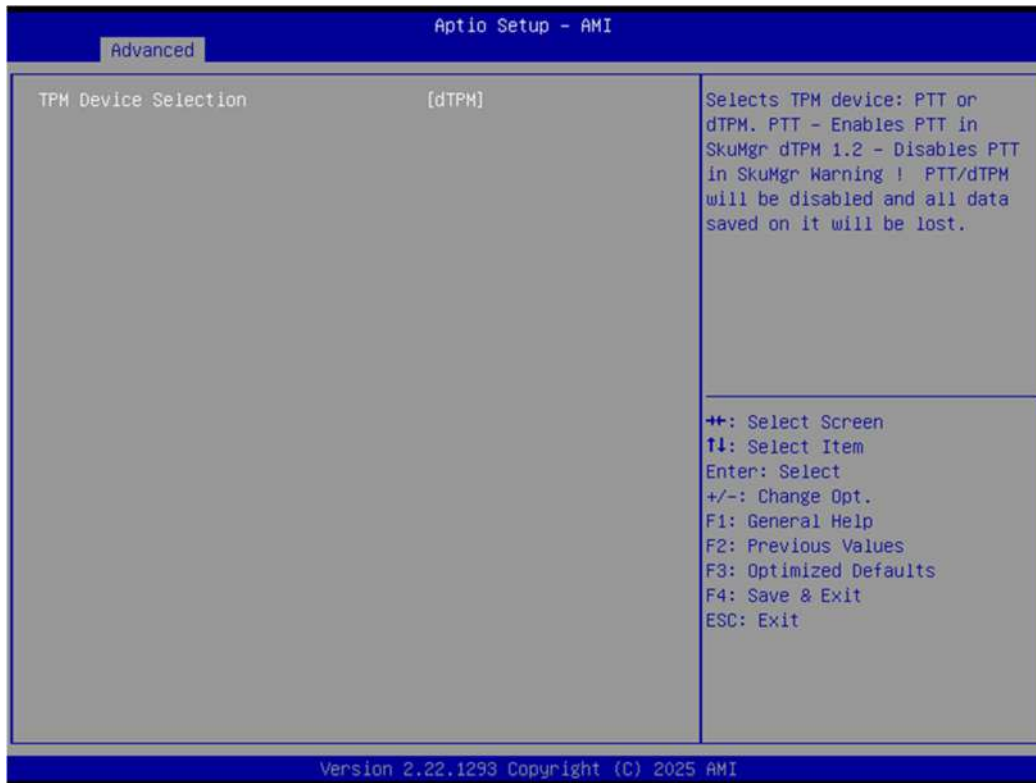

Feature	Description	Options
TPM Device Selection	Selection TPM Device: PTT or dTPM. PTT – Enabled PTT in SkuMgr dTPM 1.2 – Disabled PTT in SkuMgr Warning! PTT/dTPM. Will be disabled and all data saved on it will be lost.	★dTPM, PTT

6.3.2 Trusted Computing

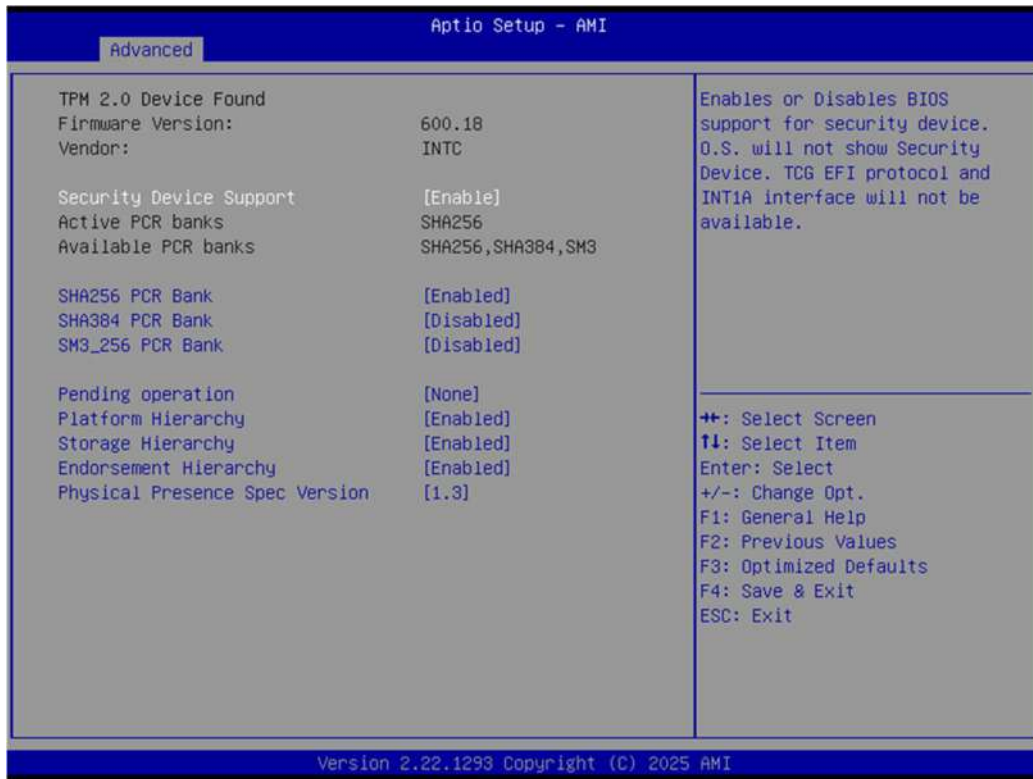

Feature	Description	Options
TPM Device Selection [PTT]		
Security Device Support	Enables or Disables BIOS support for security device. O.S. will not show Security Device. TCG EFI protocol and INT1A interface will not be available.	★Enabled, Disabled
SHA256 PCR Bank	Enables or Disables SHA256 PCR Bank.	★Enabled, Disabled
SHA384 PCR Bank	Enables or Disables SHA384 PCR Bank.	Enabled, ★Disabled
SM3_256 PCR Bank	Enables or Disables SM3_256 PCR Bank	Enabled, ★Disabled
Pending operation	Schedule an Operation for the Security Device. Note: Your Computer will reboot during restart in order to change State of Security Device.	★None, TPM Clear
Platform Hierarchy	Enables or Disables Platform Hierarchy.	★Enabled, Disabled
Storage Hierarchy	Enables or Disables Storage Hierarchy.	★Enabled, Disabled
Endorsement Hierarchy	Enables or Disables Endorsement Hierarchy.	★Enabled, Disabled
Physical Presence Spec Version	Select to Tell O.S. to Support PPI Spec Version 1.2 or 1.3. Note some HCK tests might not support 1.3.	1.2, ★1.3

6.3.3 CPU Configuration

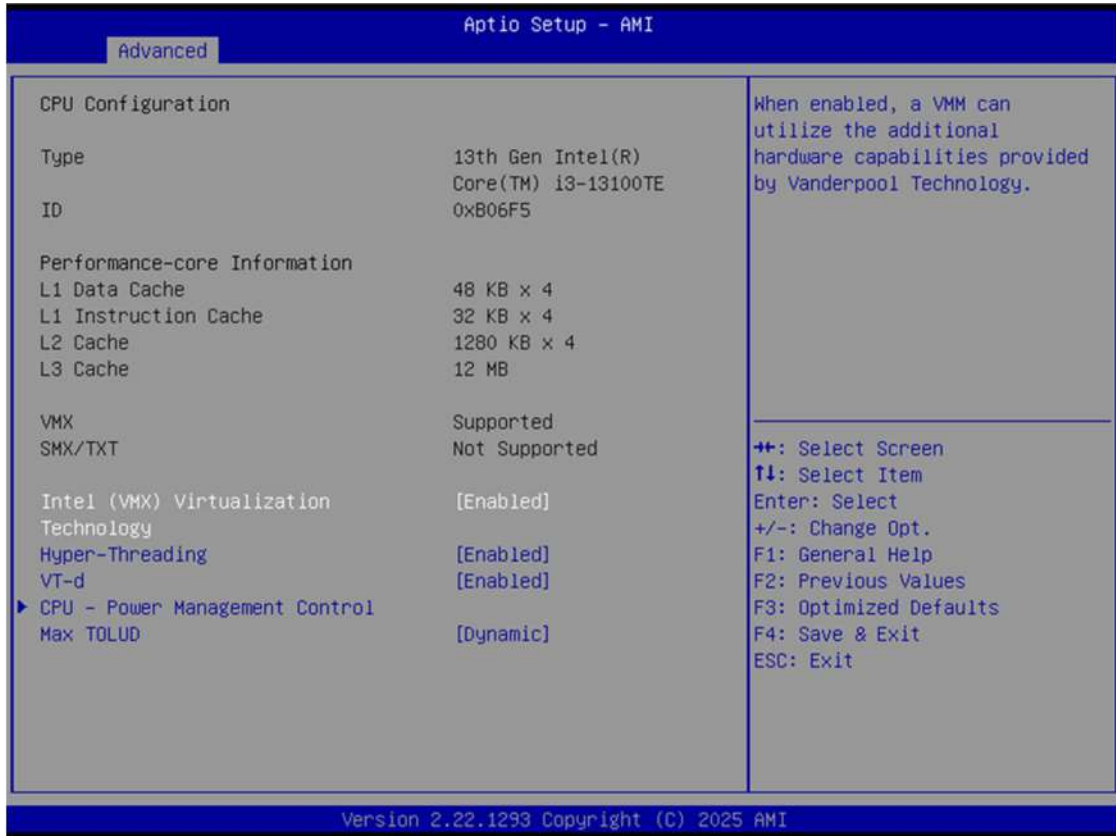

The screenshot shows the 'Advanced' menu of the Aptio Setup - AMI BIOS. The 'CPU Configuration' section is expanded, showing the following settings:

- Type: 13th Gen Intel(R) Core(TM) i3-13100TE
- ID: 0xB06F5
- Performance-core Information:
 - L1 Data Cache: 48 KB x 4
 - L1 Instruction Cache: 32 KB x 4
 - L2 Cache: 1280 KB x 4
 - L3 Cache: 12 MB
- VMX: Supported
- SMX/TXT: Not Supported
- Intel (VMX) Virtualization Technology: [Enabled]
- Hyper-Threading: [Enabled]
- VT-d: [Enabled]
- CPU - Power Management Control:
 - Max TOLUD: [Dynamic]

When enabled, a VMM can utilize the additional hardware capabilities provided by Vanderpool Technology.

Navigation keys: ++: Select Screen, ↑↓: Select Item, Enter: Select, +/-: Change Opt., F1: General Help, F2: Previous Values, F3: Optimized Defaults, F4: Save & Exit, ESC: Exit

Version 2.22.1293 Copyright (C) 2025 AMI

Feature	Description	Options
Intel (VMX)Virtualization Technology	When enabled, a VMM can utilize the additional hardware capabilities provided by Vanderpool Technology.	★Enabled, Disabled
Hyper-Threading	Enable or Disable Hyper-Threading Technology..	★Enabled, Disabled
VT-d	VT-d capability	★Enabled, Disabled
Max TOLUD	Maximum Value of TOLUD. Dynamic assignment would adjust TOLUD automatically based on largest MMIO length of installed graphic controller	★Dynamic, 0.75 GB, 1 GB, 1.25 GB, 1.5 GB, 1.75 GB, 2 GB, 2.25 GB, 2.5 GB

CPU – Power Management Control

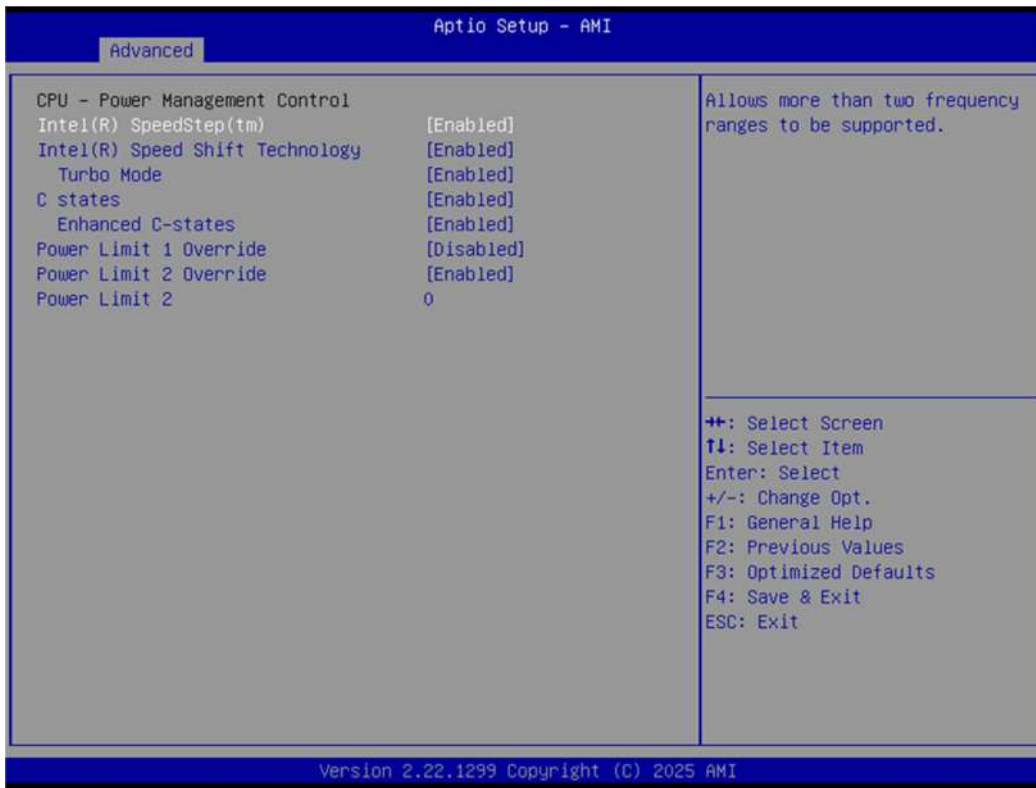

Feature	Description	Options
Intel(R) SpeedStep(tm)	Allows more than two frequency ranges to be supported.	★Enabled, Disabled
Intel(R) Speed Shift Technology	Enable/Disable Intel(R) Speed Shift Technology support. Enabling will expose the CPPC v2 interface to allow for hardware controlled P-states.	★Enabled, Disabled
Turbo Mode	Enable/Disable processor Turbo Mode. (requires EMTTM enabled too) AUTO means enabled.	★Enabled, Disabled
C states	Enable/Disable CPU Power Management. Allows CPU to go to C states when it's not 100% utilized.	★Enabled, Disabled
Enhanced C-states	Enable/Disable C1E. When enabled, CPU will switch to minimum speed when all cores enter C-State.	★Enabled, Disabled
Power Limit 1 Override	Enable/Disable Power Limit 1 override. If this option is disabled, BIOS will program the default values for power Limit 1 and Power Limit 1 Time Window.	Enabled, ★Disabled

Feature	Description	Options
Power Limit 1 Override [Enabled]		
Power Limit 1	Power Limit 1 in Millie Watt's. BIOS will round to the nearest 1/8W when programming. 0 = no custom override. For 12.50W, enter 12500. Over clocking SKU: Value must be between Max and Min Power Limits. (Specified by PACKAGE_POWER_SKU_MSR). Other SKUs: This value must be between Min Power Limit and Processor Base Power (TDP) Limit.	★0
Power Limit 2 Override	Enable/Disable Power Limit 2 override. If this option is disabled, BIOS will program the default values for Power Limit 2.	★Enabled, Disabled
Power Limit 2	Power Limit 2 value in Millie Watt's. BIOS will round to the nearest 1/8W when programming. If the value is 0, BIOS will program this value as 1.25*Processor Base Power (TDP). For 12.50w, enter 12500. Processor applies control policies such that the package power does not exceed this limit.	★0

6.3.4 Graphics Configuration



Feature	Description	Options
Primary Display	Select which of IGFX/PEG/PCI Graphics device should be Primary Display or select FORCE for dual display.	★FORCE, Auto, IGFX, PEG Slot, PCH PCI
Primary Display [IGFX]		
Internal Graphics	Keep IGFX enabled based on the setup options.	★Enabled, Disabled
RC6(Render Standby)	Check to enable render standby support.	★Enabled, Disabled

6.3.5 PCI Express Configuration

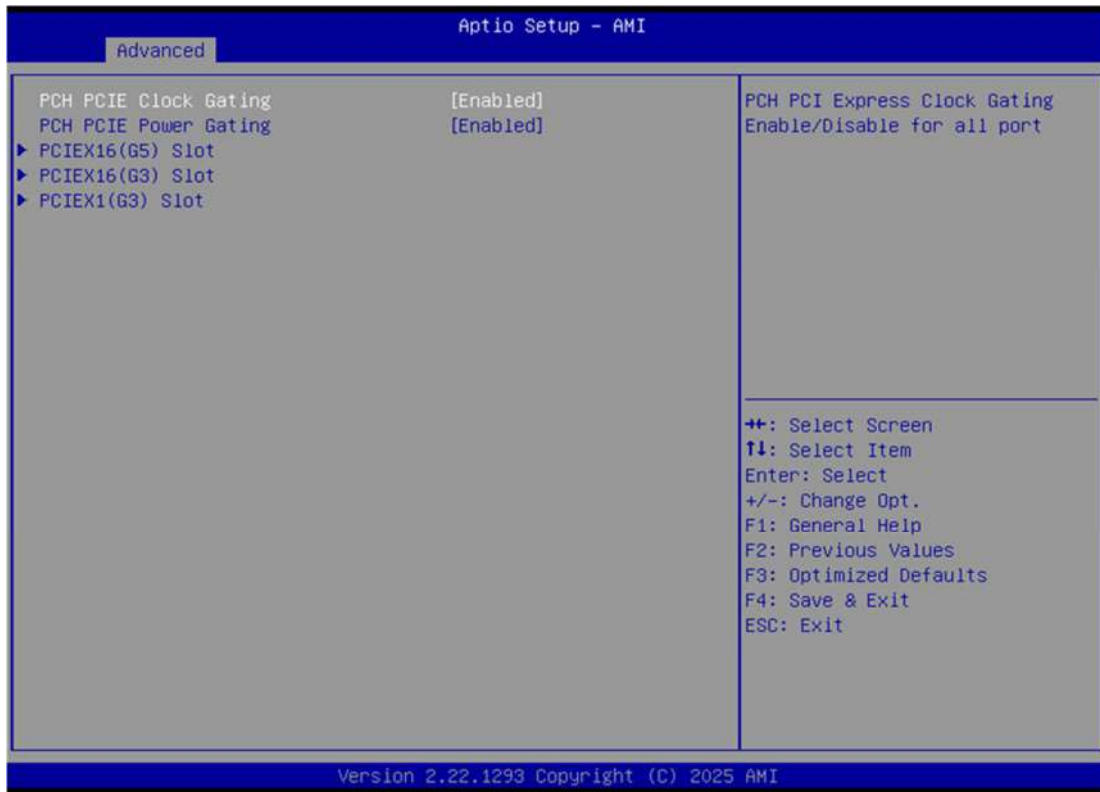

Feature	Description	Options
PCH PCIE Clock Gating	PCH PCI Express Clock Gating Enable/Disable for all port	★Enabled, Disabled
PCH PCIE Power Gating	PCH PCI Express Power Gating Enable/Disable for all port	★Enabled, Disabled
PCIEx16 (G5) Slot	PCI Express Configuration settings.	
PCIEx16 (G3) Slot	Control the PCI Express Root Port.	
PCIEx1 (G3) Slot	Control the PCI Express Root Port.	

PCIEx16(G5)_1 Slot

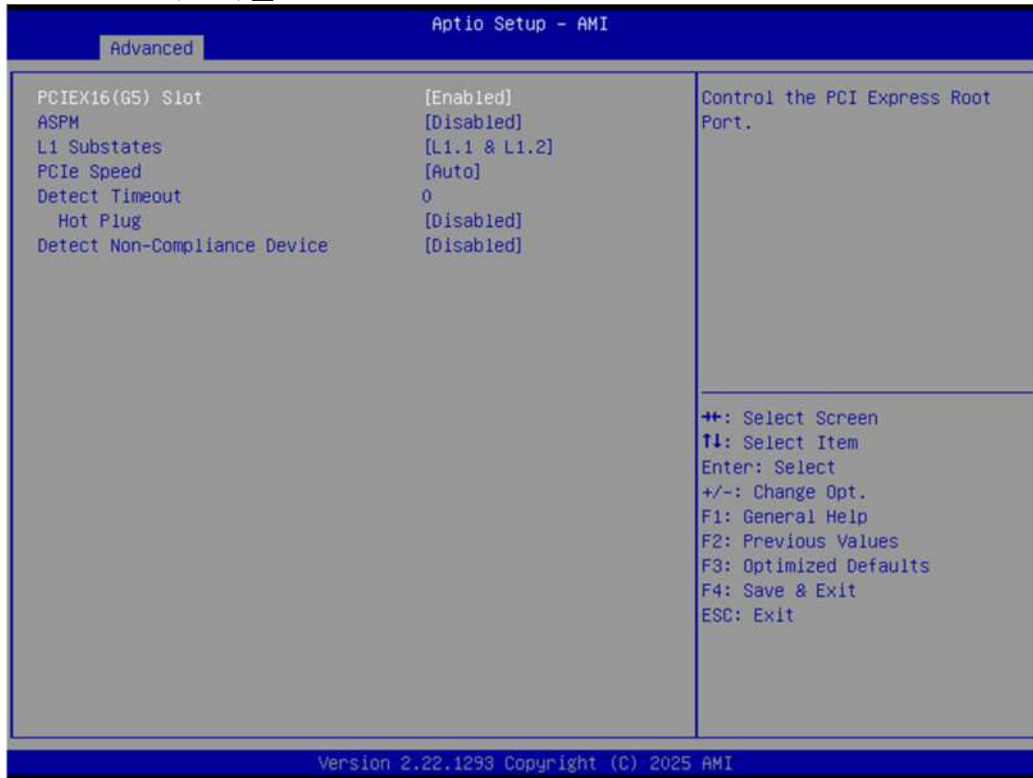

Feature	Description	Options
PCIEx16 (G5) Slot	Control the PCI Express Root Port.	★Enabled, Disabled
ASPM	Set the ASPM Level: Force L0s – Force all links to L0s State AUTO-BIOS auto configure DISABLE – Disables ASPM	★Disabled, L0s, L1, L0sL1
L1 Substates	PCI Express L1 Substates settings. L1SS cannot be enabled when CLKREQMSG is disabled	★L1.1 & L1.2, Disabled, L1.1
PCIe Speed	Configure PCIe speed	★Auto, Gen1, Gen2, Gen3, Gen4, Gen5
Detect Timeout	The number of milliseconds reference code will wait for enabled ports before assuming there is no device and potentially disabling the port.	★0
Hot Plug	PCI Express Hot Plug Enable/Disable	Enabled, ★Disabled
Detect Non-compliance Device	Enable when using Compliance Load Board	Enabled, ★Disabled

PCIEx16(G3) Slot



Feature	Description	Options
PCIEx16 (G3) Slot	Control the PCI Express Root Port.	★Enabled, Disabled
ASPM	Set the ASPM Level: Force L0s – Force all links to L0s State AUTO-BIOS auto configure DISABLE – Disables ASPM	★Disabled, L1, Auto
L1 Substates	PCI Express L1 Substates settings.	★L1.1 & L1.2, Disabled, L1.1
PCIe Speed	Configure PCIe speed	★Auto, Gen1, Gen2, Gen3
Detect Timeout	The number of milliseconds reference code will wait for enabled ports before assuming there is no device and potentially disabling the port.	★0
Hot Plug	PCI Express Hot Plug Enable/Disable	Enabled, ★Disabled
Detect Non-compliance Device	Enable when using Compliance Load Board	Enabled, ★Disabled

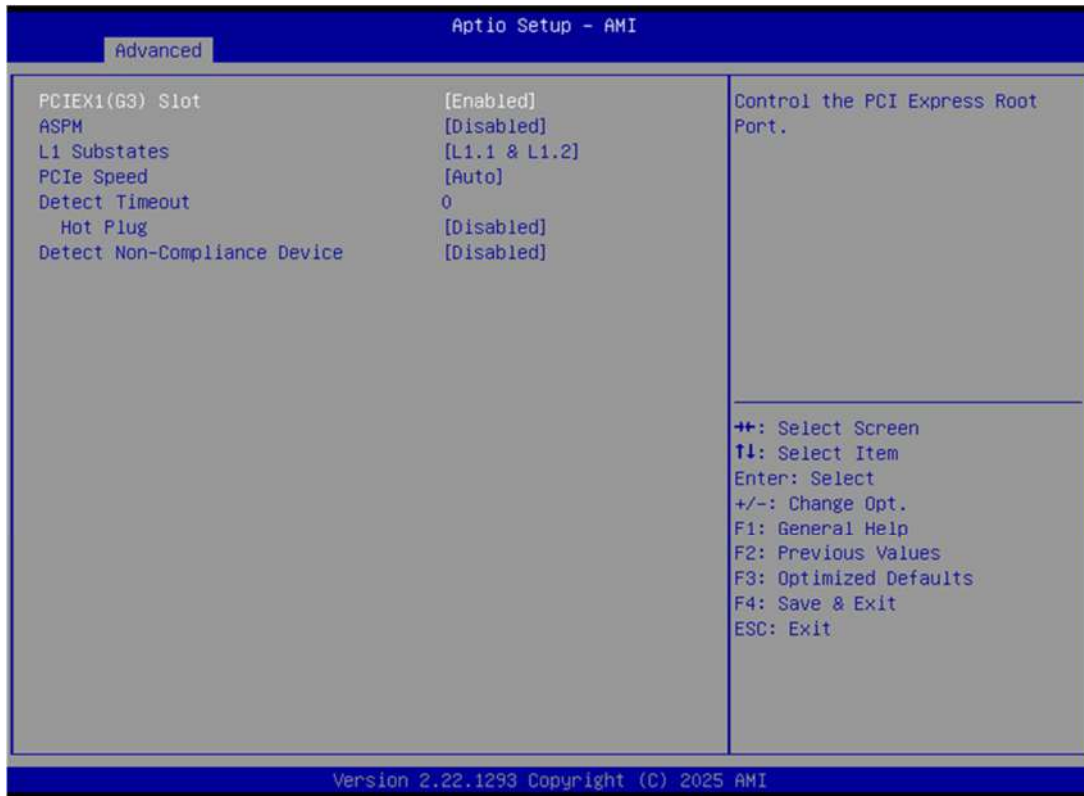

Feature	Description	Options
PCIEx1 (G3) Slot	Control the PCI Express Root Port.	★Enabled, Disabled
ASPM	Set the ASPM Level: Force L0s – Force all links to L0s State AUTO-BIOS auto configure DISABLE – Disables ASPM	★Disabled, L1, Auto
L1 Substates	PCI Express L1 Substates settings.	★L1.1 & L1.2, Disabled, L1.1
PCIe Speed	Configure PCIe speed	★Auto, Gen1, Gen2, Gen3
Detect Timeout	The number of milliseconds reference code will wait for enabled ports before assuming there is no device and potentially disabling the port.	★0
Hot Plug	PCI Express Hot Plug Enable/Disable	Enabled, ★Disabled
Detect Non-compliance Device	Enable when using Compliance Load Board	Enabled, ★Disabled

6.3.6 CSM Configuration

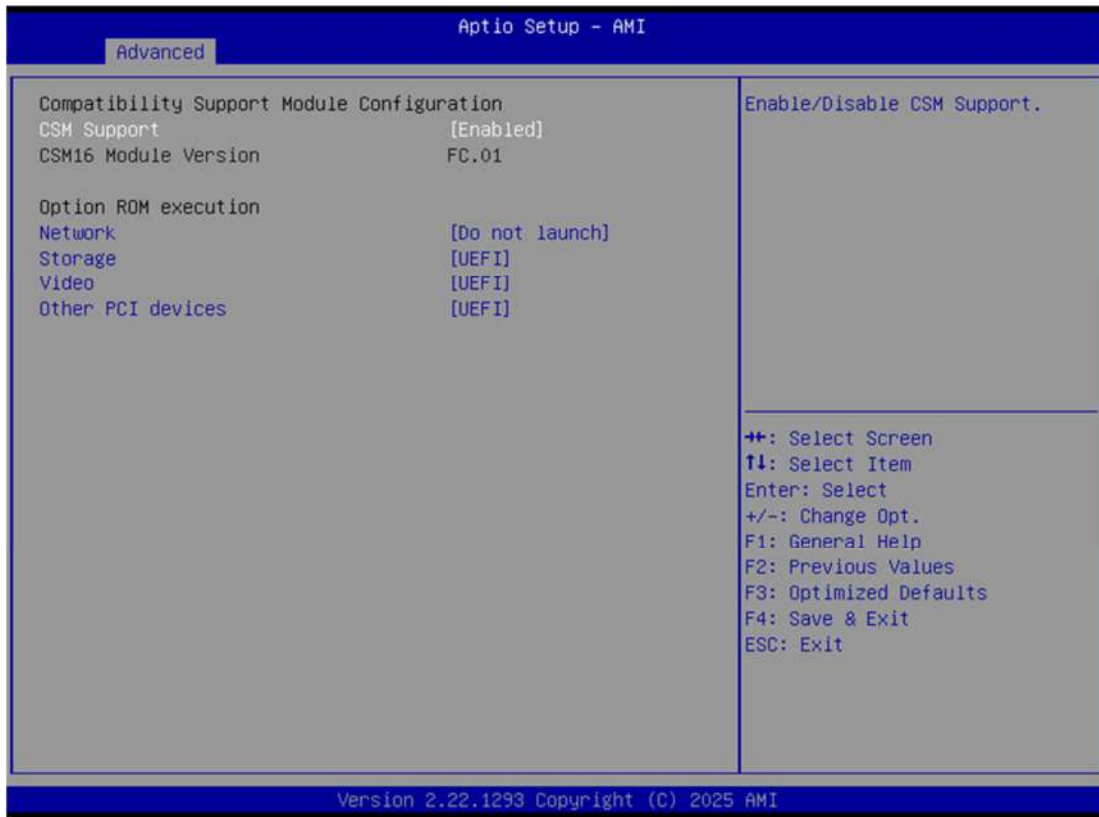

Feature	Description	Options
CSM Support		Enabled, ★Disabled
CSM Support [Enabled]		
Network	Controls the execution of UEFI and Legacy Network OpROM	★Do not launch, UEFI, Legacy
Storage	Controls the execution of UEFI and Legacy Storage OpROM	Do not launch, ★UEFI, Legacy
Video	Controls the execution of UEFI and Legacy Video OpROM	Do not launch, ★UEFI, Legacy
Other PCI Devices	Determines OpROM execution policy for devices other than Network, Storage, or Video	Do not launch, ★UEFI, Legacy

6.3.7 Super IO Configuration

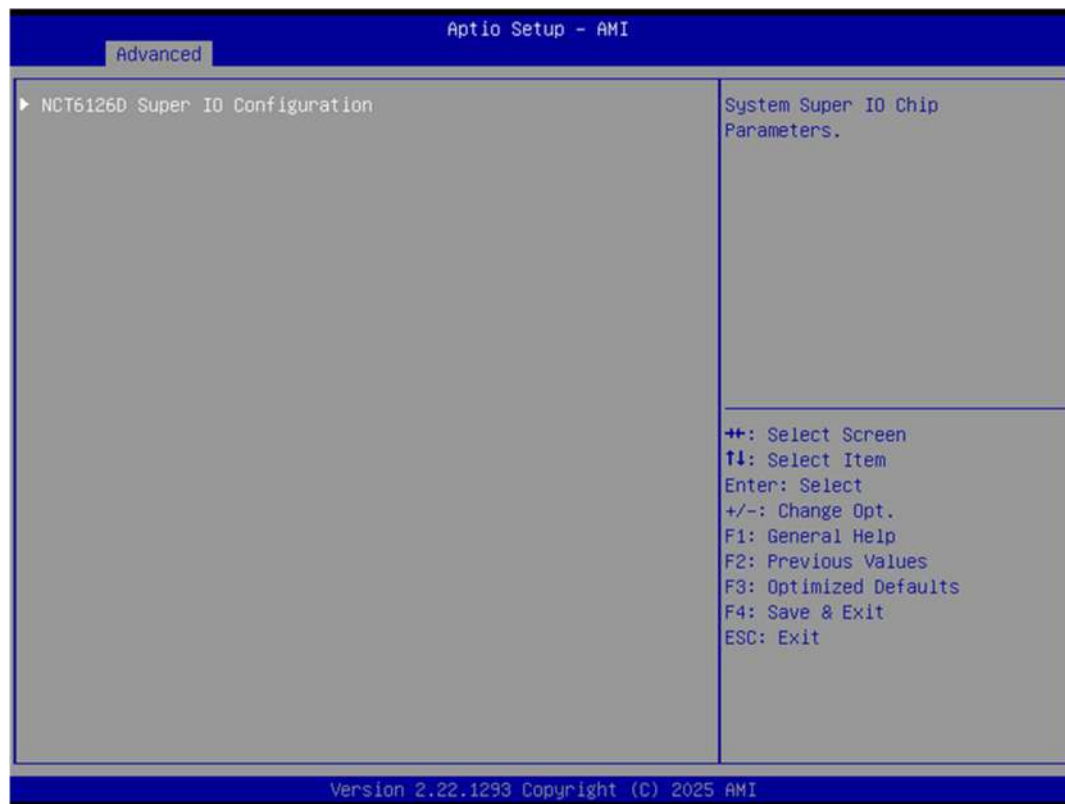

Serial Port 1 Configuration

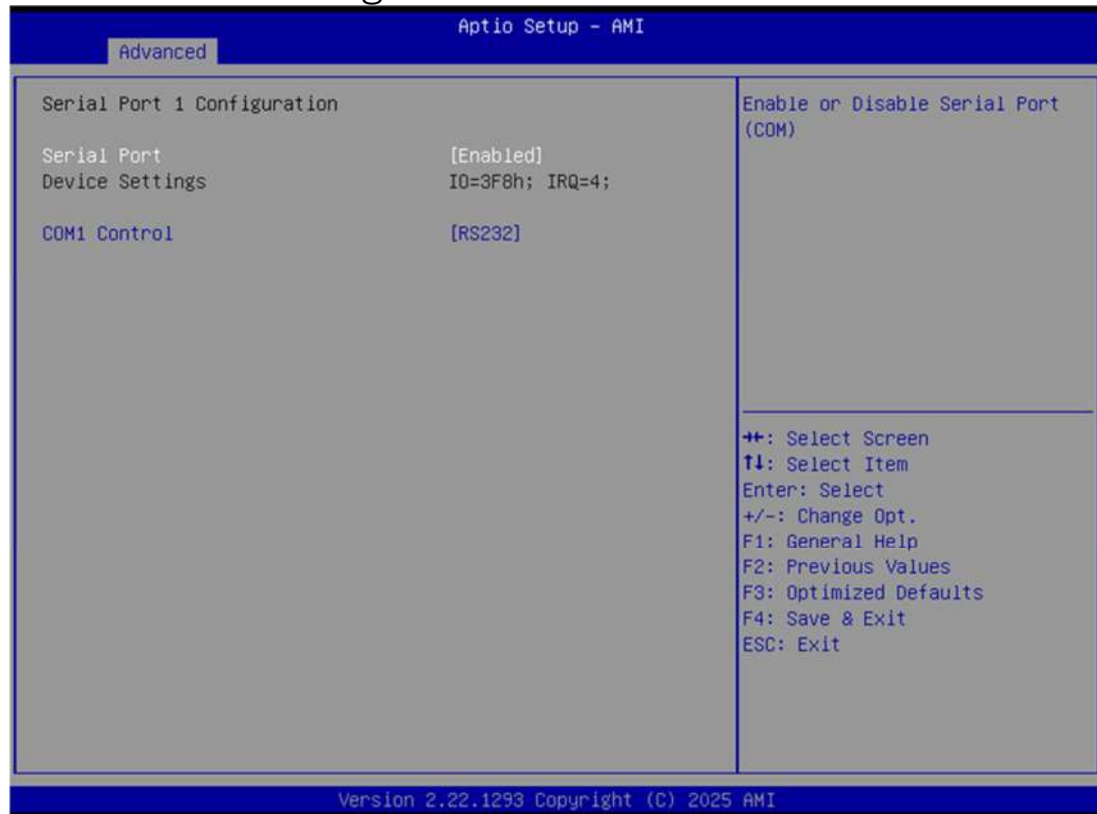

Feature	Description	Options
Serial Port	Enable or Disable Serial Port (COM)	★Enabled, Disabled
COM1 Control	Select COM1 mode. RS232, RS422 or RS485	★RS232, RS422, RS485

Serial Port 2 Configuration

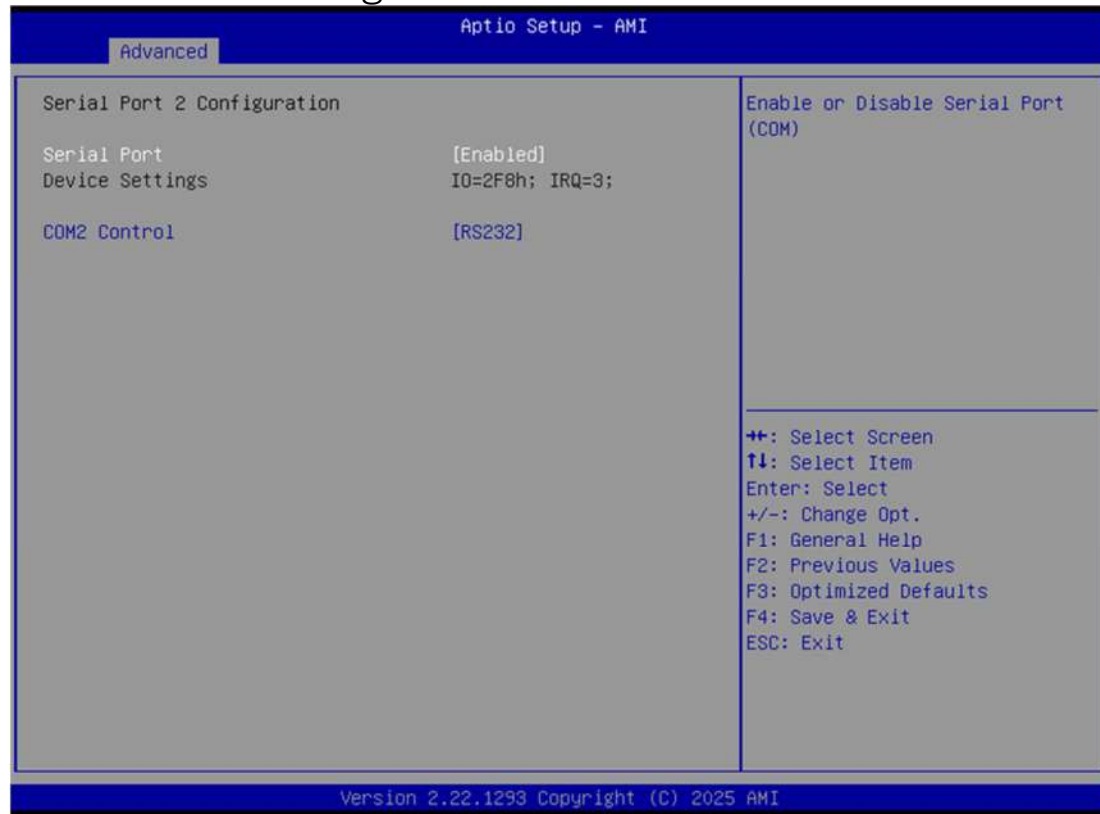

Feature	Description	Options
Serial Port	Enable or Disable Serial Port (COM)	★Enabled, Disabled
COM2 Control	Select COM2 mode. RS232, RS422 or RS485	★RS232, RS422, RS485

Serial Port 3 Configuration

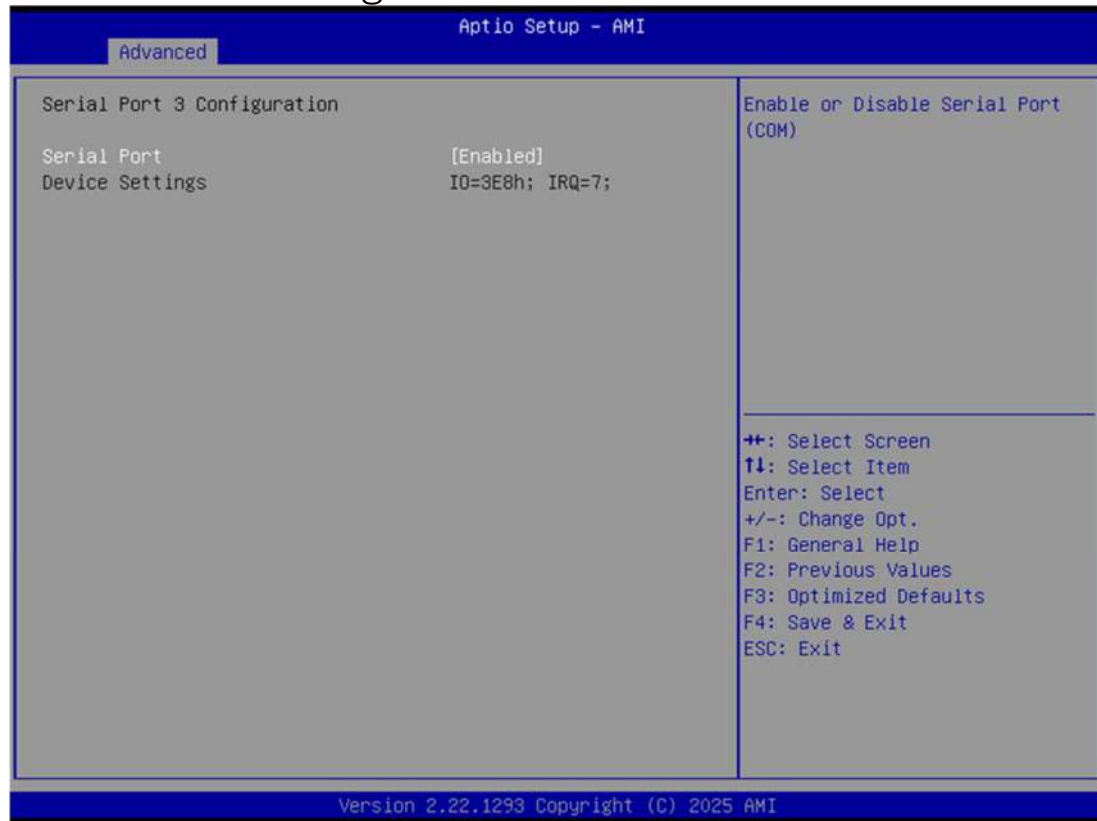

Feature	Description	Options
Serial Port	Enable or Disable Serial Port (COM)	★Enabled, Disabled

Serial Port 4 Configuration



Feature	Description	Options
Serial Port	Enable or Disable Serial Port (COM)	★Enabled, Disabled

Serial Port 5 Configuration

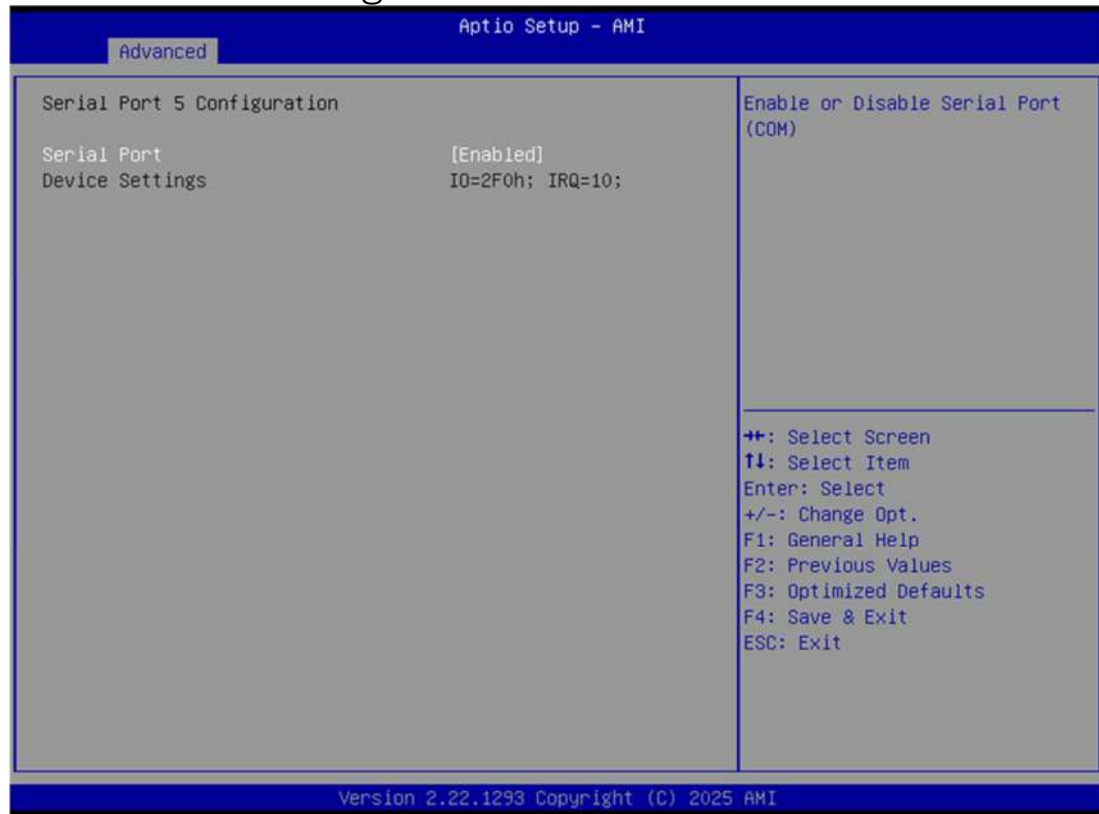

Feature	Description	Options
Serial Port	Enable or Disable Serial Port (COM)	★Enabled, Disabled

Serial Port 6 Configuration

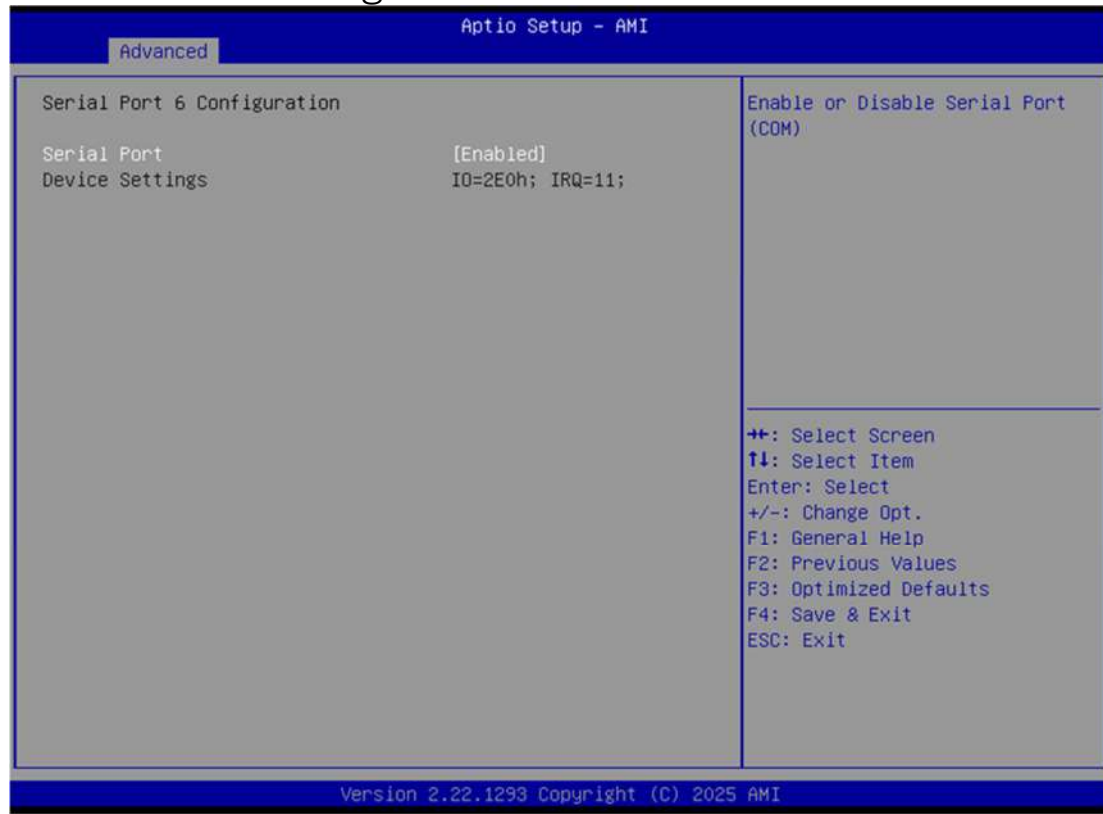

Feature	Description	Options
Serial Port	Enable or Disable Serial Port (COM)	★Enabled, Disabled

Parallel Port Configuration

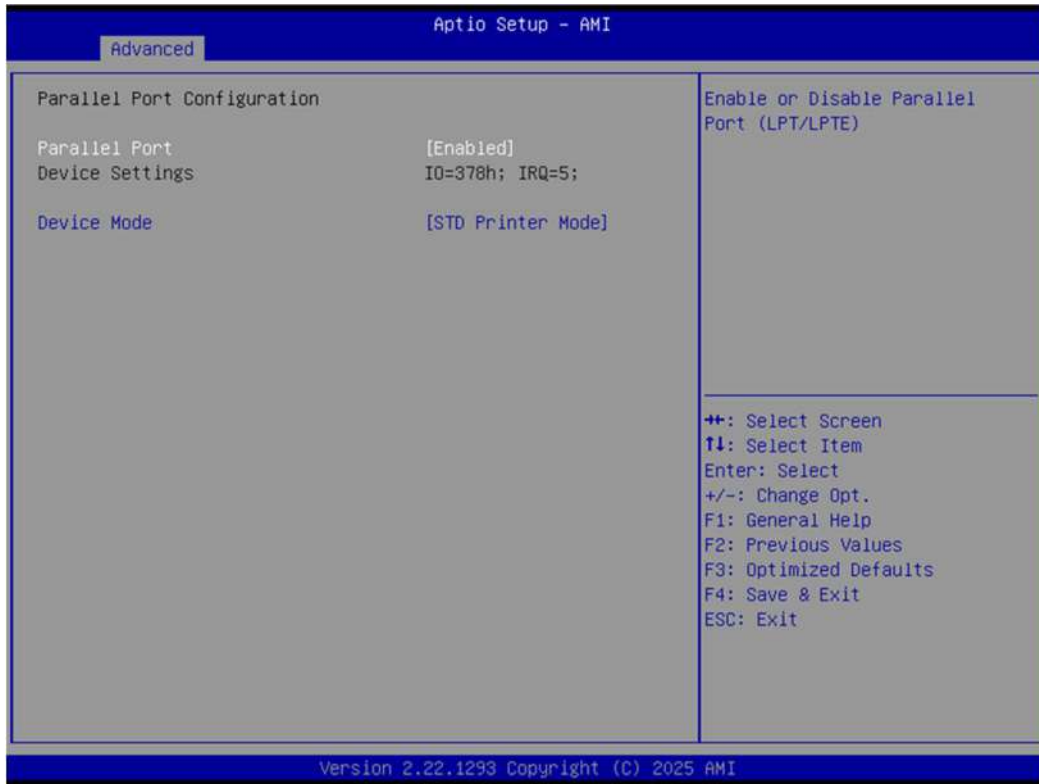

Feature	Description	Options
Parallel Port	Enable or Disable Parallel Port (LPT/LPTE)	★Enabled, Disabled
Device Mode	Change the Printer Port mode.	★STD Printer Mode, SPP Mode, EPP-1.9 and SPP Mode EPP-1.7 and SPP Mode ECP Mode ECP and EPP-1.9 Mode ECP and EPP-1.7 Mode

6.3.8 Serial Console Redirection

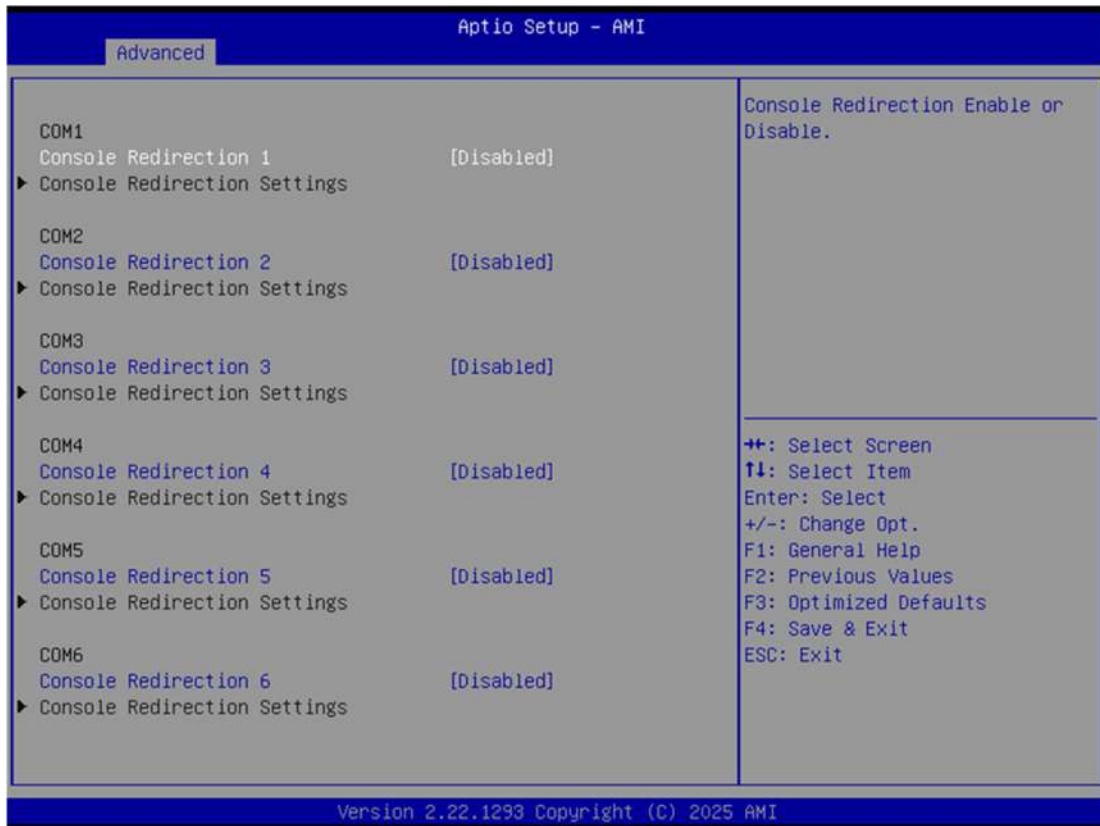

Feature	Description	Options
Console Redirection 1	Console Redirection Enable or Disable.	Enabled, ★Disabled
Console Redirection 2	Console Redirection Enable or Disable.	Enabled, ★Disabled
Console Redirection 3	Console Redirection Enable or Disable.	Enabled, ★Disabled
Console Redirection 4	Console Redirection Enable or Disable.	Enabled, ★Disabled
Console Redirection 5	Console Redirection Enable or Disable.	Enabled, ★Disabled
Console Redirection 6	Console Redirection Enable or Disable.	Enabled, ★Disabled
Console Redirection 1 ~ 6 [Enabled]		
Console Redirection Settings	The settings specify how the host computer and the remote computer (which the user is using) will exchange data. Both computers should have the same or compatible settings.	

COM1 – COM6 Console Redirection Settings

The settings specify how the host computer and the remote computer (which the user is using) will exchange data. Both computers should have the same or compatible settings.

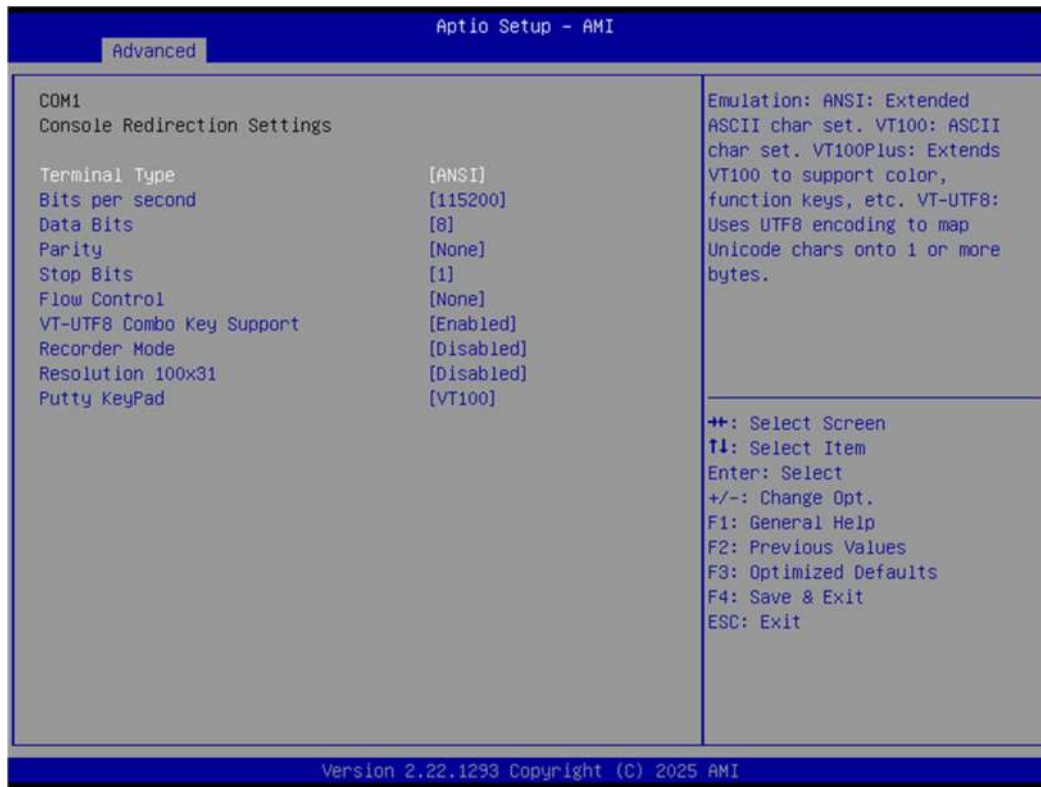

Feature	Description	Options
Terminal Type	Emulation: ANSI: Extended ASCII char set. VT100: ASCII char set. VT100Plus: Extends VT100 to support color, function keys, etc. VT-UTF8: Uses UTF8 encoding to map Unicode chars onto 1 or more bytes.	★ANSI, VT100, VT100Plus, VT-UTF8
Bits per second	Selects Serial port transmission speed. The speed must be matched on the other side. Long or noisy lines may require lower speeds.	★115200, 9600, 19200, 38400, 57600, 230400, 460800, 921600
Data bits	Data bits	★8, 7

Feature	Description	Options
Parity	A parity bit can be sent with the data bits to detect some transmission errors. Even: parity bit is 0 if the num of 1's in the data bits is even. Odd: parity bit is 0 if num of 1's in the data bits is odd. Mark: parity bit is always 1. Space: parity bit is always 0. Mark and Space Parity do not allow for error detection. They can be used as an additional data bit.	★None, Even, Odd, Mark, Space
Stop Bits	Stop bits indicate the end of a serial data packet. (A start bit indicates the beginning). The standard setting is 1 stop bit. Communication with slow devices may require more than 1 stop bit.	★1, 2
Flow Control	Flow control can prevent data loss from buffer overflow. When sending data, if the receiving buffers are full, a 'stop' signal can be sent to stop the data flow. Once the buffers are empty, a 'start' signal can be sent to re-start the flow. Hardware flow control uses two wires to send start/stop signals.	★None, Hardware RTS/CTS
VT-UTF8 Combo Key Support	Enable VT-UTF8 Combination Key Support for ANSI/VT100 terminals	★Enabled, Disabled
Recorder Mode	With this mode enabled only text will be sent. This is to capture Terminal data.	Enabled, ★Disabled
Resolution 100x31	Enables or disables extended terminal resolution	Enabled, ★Disabled
Putty KeyPad	Select FunctionKey and KeyPad on Putty.	★VT100, LINUX, XTERMR6, SCO, ESCN, VT400

6.3.9 SATA Configuration

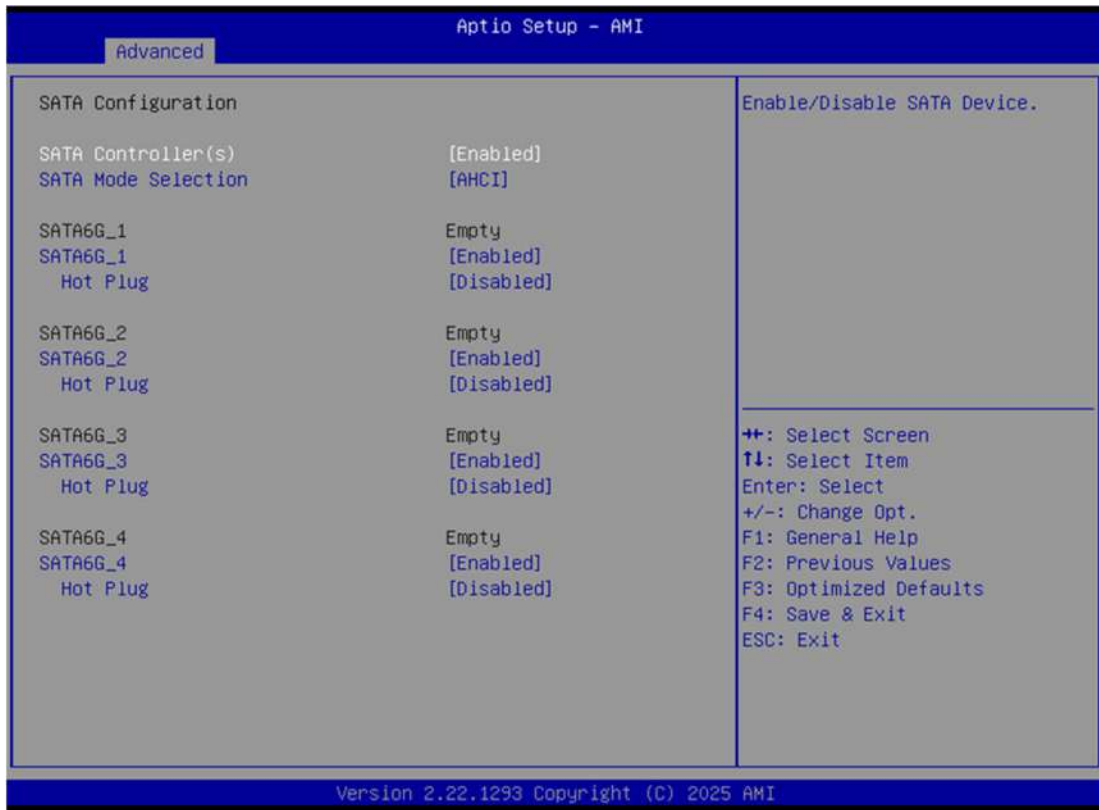

Feature	Description	Options
SATA Controller(s)	Enable/Disable SATA Device.	★Enabled, Disabled
SATA Mode Selection	Determines how SATA controller(s) operate.	★AHCI
SATA6G_1	Enable or Disable SATA Port	★Enabled, Disabled
Hot Plug	Designates this port as Hot Pluggable.	Enabled, ★Disabled
SATA6G_2	Enable or Disable SATA Port	★Enabled, Disabled
Hot Plug	Designates this port as Hot Pluggable.	Enabled, ★Disabled
SATA6G_3	Enable or Disable SATA Port	★Enabled, Disabled
Hot Plug	Designates this port as Hot Pluggable.	Enabled, ★Disabled
SATA6G_4	Enable or Disable SATA Port	★Enabled, Disabled
Hot Plug	Designates this port as Hot Pluggable.	Enabled, ★Disabled

6.3.10 Network Stack Configuration

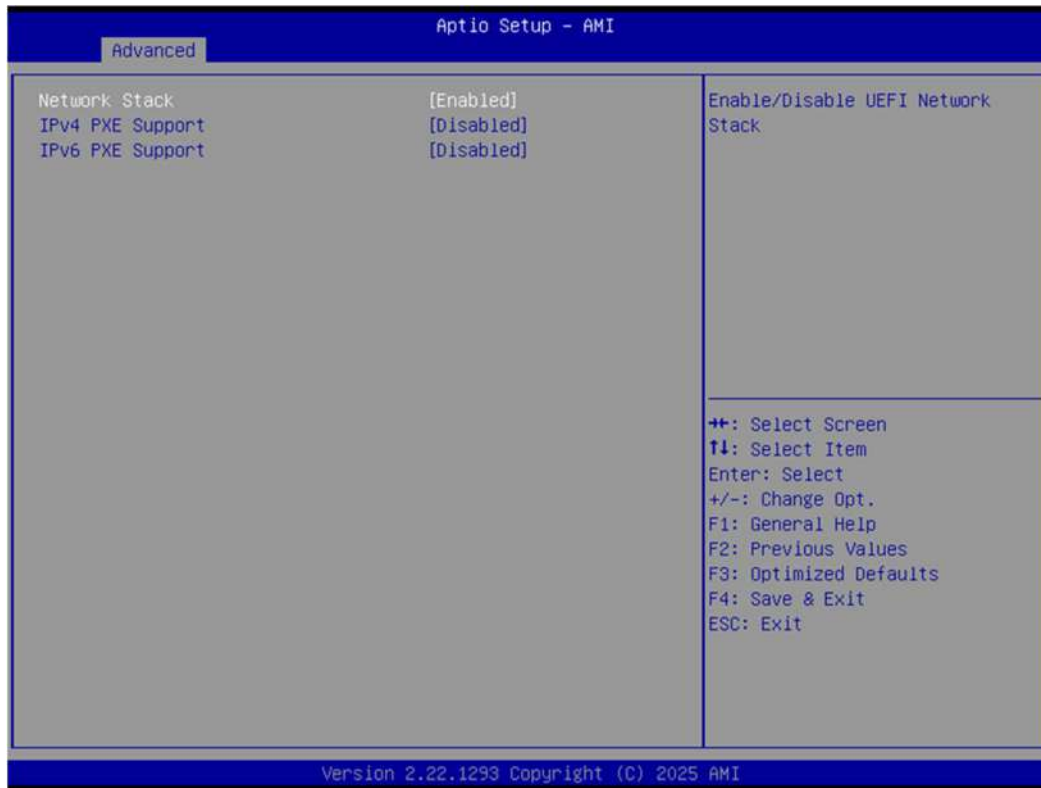

Feature	Description	Options
Network Stack	Enable/Disable UEFI Network Stack	★Disabled, Enabled
Network Stack [Enabled]		
IPv4 PXE Support	Enable/Disable IPv4 PXE boot support. If disabled, IPv4 PXE boot support will not be available.	★Disabled, Enabled
IPv6 PXE Support	Enable/Disable IPv6 PXE boot support. If disabled, IPv6 PXE boot support will not be available.	★Disabled, Enabled

6.3.11 USB Configuration

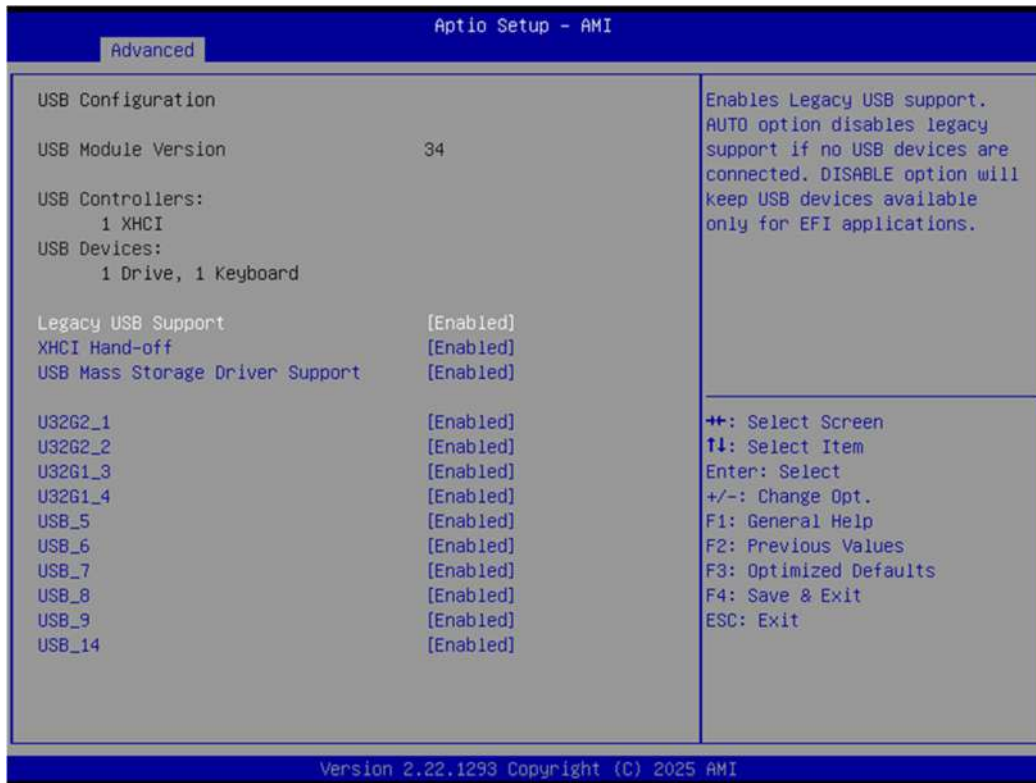

Feature	Description	Options
Legacy USB Support	Enables Legacy USB Support. AUTO option disables legacy support if no USB devices are connected. DISABLE option will keep USB devices available only for EFI applications.	★Enabled, Disabled, Auto
XHCI Hand-off	This is a workaround for Oses without XHCI hand-off support. The XHCI ownership change should be claimed by XHCI driver.	★Enabled, Disabled
USB Mass Storage Driver Support	Enable/Disable USB Mass Storage Driver Support.	★Enabled, Disabled
U32G2_1	Enabled/Disabled this USB Physical connector (physical port). Once disabled, any USB devices plug into the connector will not be detected by BIOS or OS.	★Enabled, Disabled
U32G2_2	Enabled/Disabled this USB Physical connector (physical port). Once disabled, any USB devices plug into the connector will not be detected by BIOS or OS.	★Enabled, Disabled

Feature	Description	Options
U32G1_3	Enabled/Disabled this USB Physical connector (physical port). Once disabled, any USB devices plug into the connector will not be detected by BIOS or OS.	★Enabled, Disabled
U32G1_4	Enabled/Disabled this USB Physical connector (physical port). Once disabled, any USB devices plug into the connector will not be detected by BIOS or OS.	★Enabled, Disabled
USB_5	Enabled/Disabled this USB Physical connector (physical port). Once disabled, any USB devices plug into the connector will not be detected by BIOS or OS.	★Enabled, Disabled
USB_6	Enabled/Disabled this USB Physical connector (physical port). Once disabled, any USB devices plug into the connector will not be detected by BIOS or OS.	★Enabled, Disabled
USB_7	Enabled/Disabled this USB Physical connector (physical port). Once disabled, any USB devices plug into the connector will not be detected by BIOS or OS.	★Enabled, Disabled
USB_8	Enabled/Disabled this USB Physical connector (physical port). Once disabled, any USB devices plug into the connector will not be detected by BIOS or OS.	★Enabled, Disabled
USB_9	Enabled/Disabled this USB Physical connector (physical port). Once disabled, any USB devices plug into the connector will not be detected by BIOS or OS.	★Enabled, Disabled
USB_14	Enabled/Disabled this USB Physical connector (physical port). Once disabled, any USB devices plug into the connector will not be detected by BIOS or OS.	★Enabled, Disabled

6.3.12 NVMe Configuration



6.3.13 Onboard Device Configuration

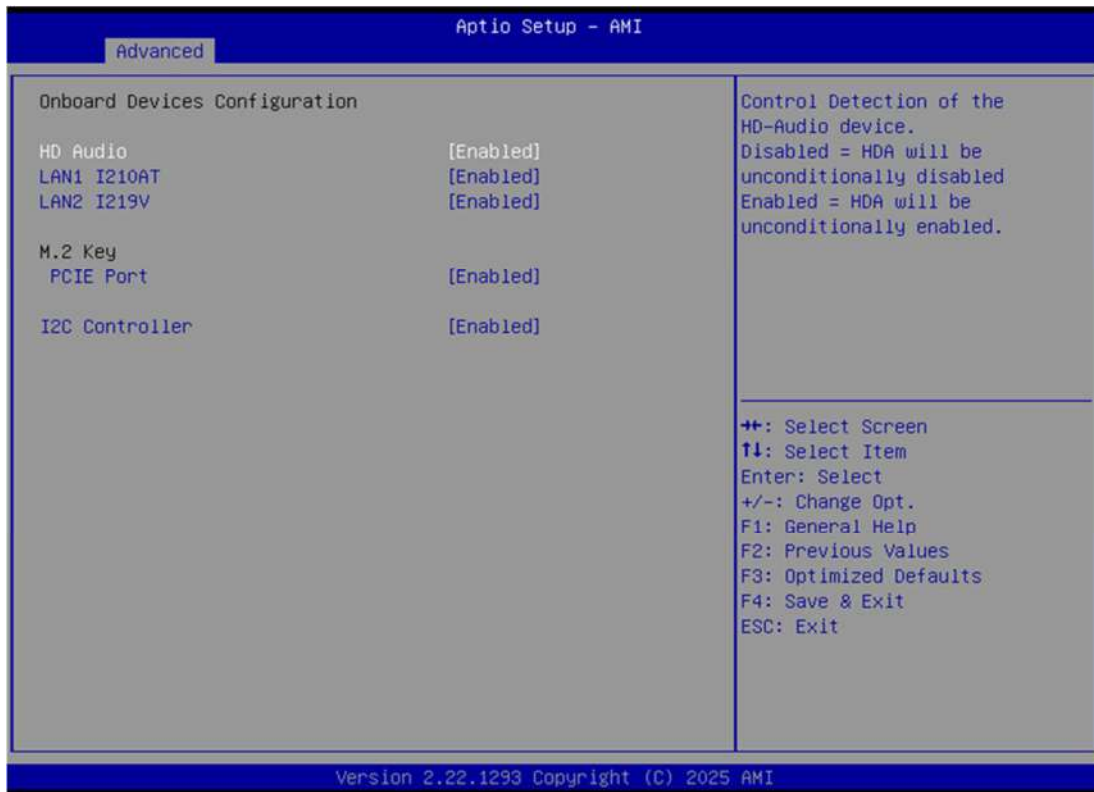

Feature	Description	Options
HD Audio	Control Detection of the HD-Audio device. Disabled = HDA will be unconditionally disabled. Enabled = HDA will be unconditionally enabled.	★Enabled, Disabled
LAN1 I210AT	Enable/Disable LAN1	★Enabled, Disabled
LAN2 I219V	Enable/Disable LAN2	★Enabled, Disabled
M.2 Key		
PCIE Port	Enable/Disable M.2 PCIE Port	★Enabled, Disabled
I2C Controller	Enable/Disable I2C Controller	★Enabled, Disabled

6.3.14 Miscellaneous

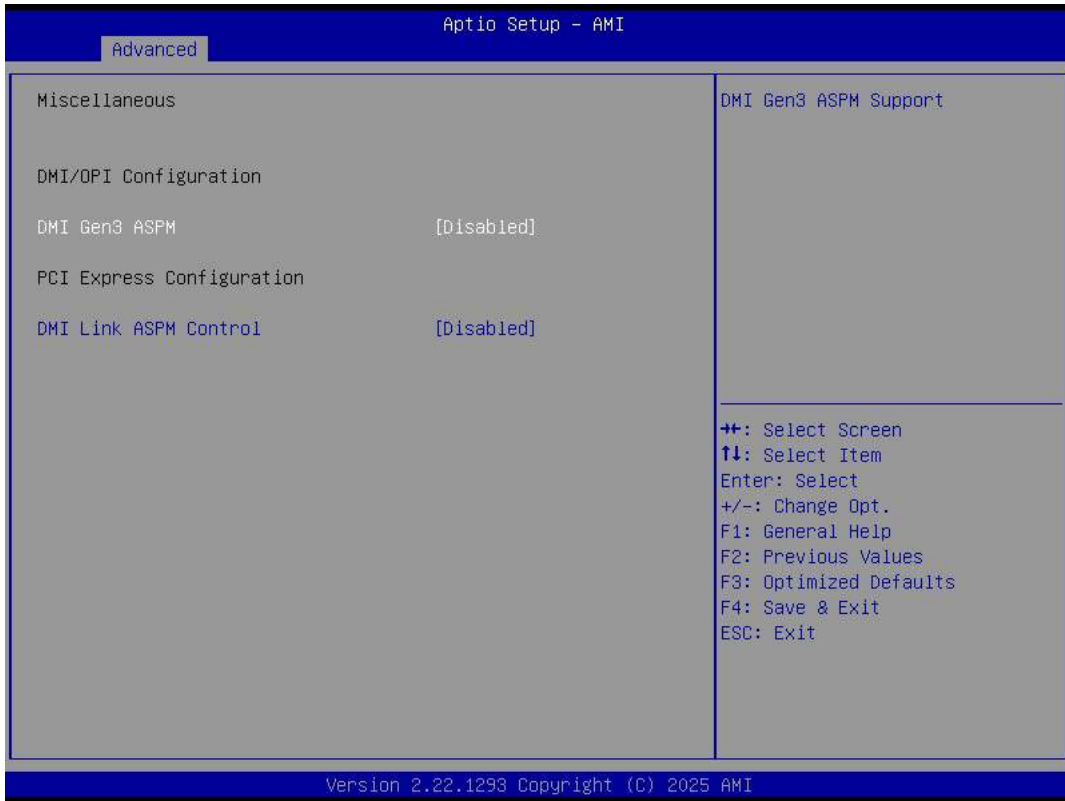

Feature	Description	Options
DMI/OPI Configuration		
DMI Gen3 ASPM	DMI Gen3 ASPM Support	★Disabled, Auto, ASPM L0s, ASPM L1, ASPM L0sL1
PCI Express Configuration		
DMI Link ASPM Control	The Control of Active State Power Management of the DMI Link.	★Disabled, L1, Auto

6.3.15 APM Configuration



Feature	Description	Options
ErP Ready	Allow BIOS to switch off some power at S4/S5 to get the system ready for ErP requirement. When set to Enabled, all other PME options will be switched off.	★Disabled, Enabled
Restore AC Power Loss	Select AC power state when power is re-applied after a power failure.	★S5 State, S0 State
Power On By PCIE	Enable or disable the Wake-on-LAN function of the onboard LAN controller or other installed PCIE LAN devices.	★Disabled, Enabled
Power On By PS2	Enable/disable resume from S5 Via PS2	★Disabled, Enabled
Power On By Ring	Power On By Ring	★Disabled, Enabled
Power On By RTC	Select whether to enable Wake Up on Alarm, to turn on your system on a special day of the month, special day of the week or daily. NOTE: Values in these fields may be overwritten by the operating system.	★Disabled, Single event, Daily event, Weekly event, Monthly event

Feature	Description	Options
Power On By RTC [Single event]		
Wake up hour	Select 0-23 For example enter 3 for 3am and 15 for 3pm	★0
Wake up minute	Select 0-59 for Minute	★0
Wake up second	Select 0-59 for Second	★0
Power On By RTC [Daily event]		
Wake up hour	Select 0-23 For example enter 3 for 3am and 15 for 3pm	★0
Wake up minute	Select 0-59 for Minute	★0
Wake up second	Select 0-59 for Second	★0
Power On By RTC [Weekly event]		
Alarm day of Week	Select the day of the week when the system is to wake up.	★Sunday, Monday, Tuesday, Wednesday, Thursday, Friday, Saturday
Wake up hour	Select 0-23 For example enter 3 for 3am and 15 for 3pm	★0
Wake up minute	Select 0-59 for Minute	★0
Wake up second	Select 0-59 for Second	★0
Power On By RTC [Monthly event]		
Day of the Month	RTC Alarm Date (Days)	★15
Wake up hour	Select 0-23 For example enter 3 for 3am and 15 for 3pm	★0
Wake up minute	Select 0-59 for Minute	★0
Wake up second	Select 0-59 for Second	★0

6.3.16 EZ-Flash



Feature	Description	Options
Enter Ez-Flash mode	In this mode, select a BIOS update file from your drive to update	

6.3.17 Watchdog Timer

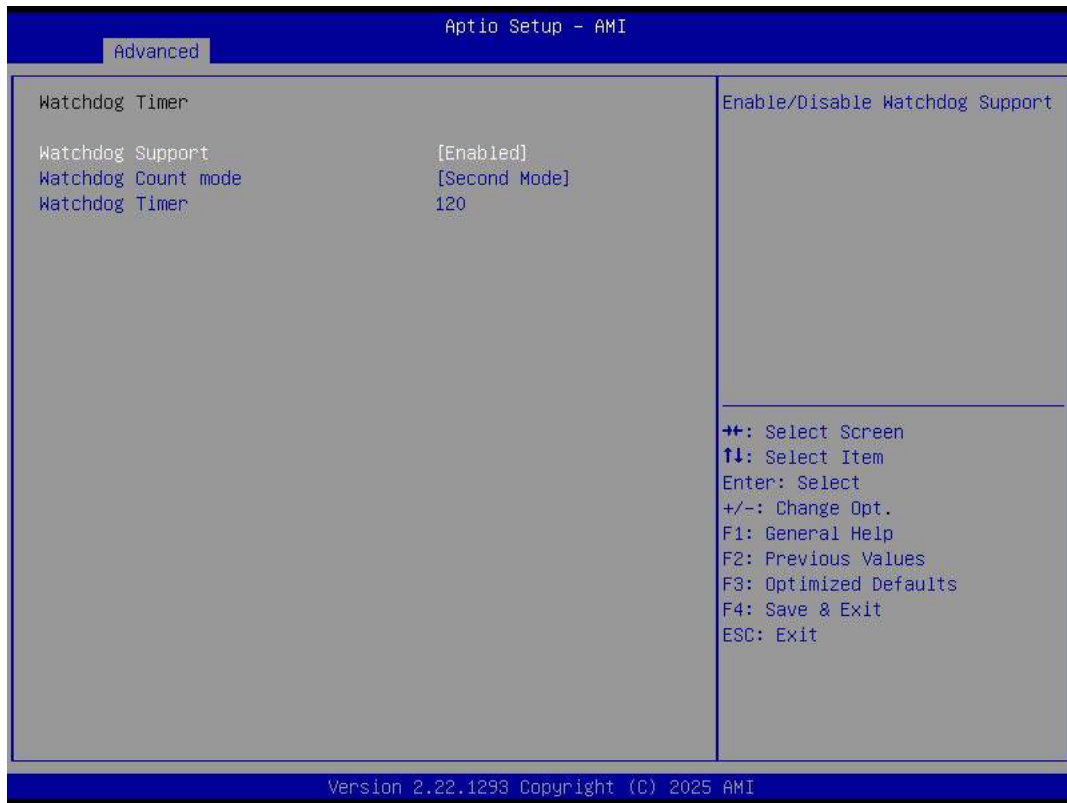

Feature	Description	Options
Watchdog Support	Enabled /Disabled Watchdog Support	★Enabled, Disabled
Watchdog Count Mode	Select Watchdog Timer I count mode	★Second Mode, Minute Mode
Watchdog Timer	Watchdog Timer I Time-out value.	★120

6.4 Hardware Monitor

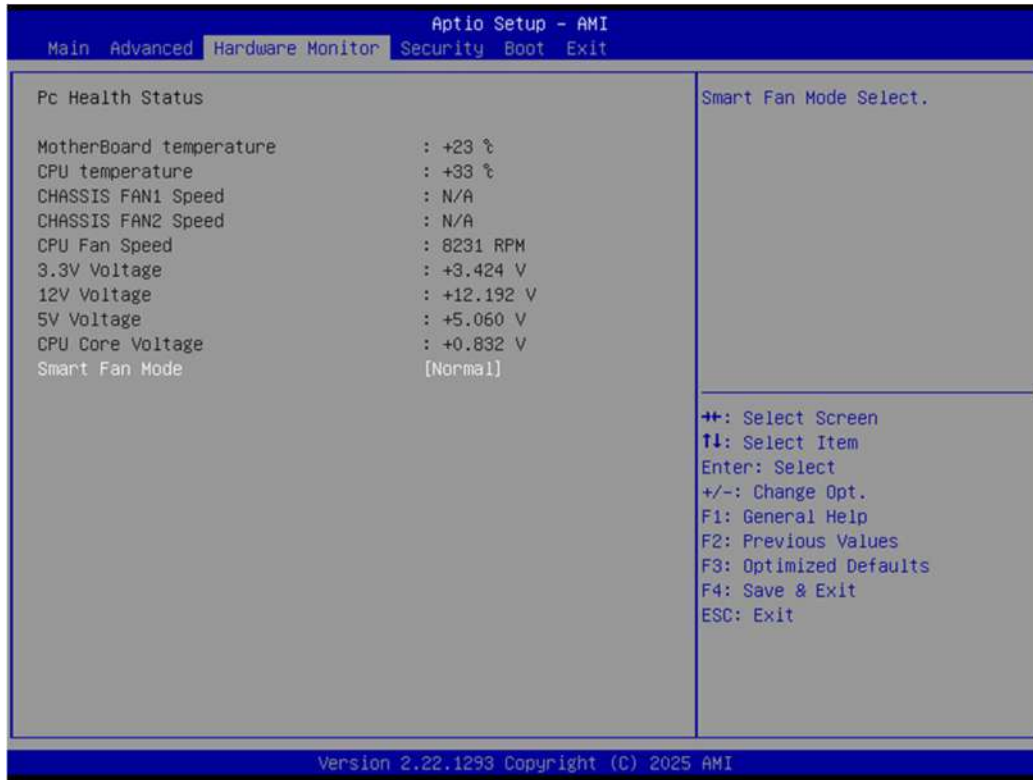

Feature	Description	Options
Smart Fan Mode	Smart Fan Mode select.	★Normal, Disabled, Manual Mode
Smart Fan Mode [Manual Mode]		
Smart Fan Function	Smart Fan Function Setting	

Chassis Fan 1 Settin

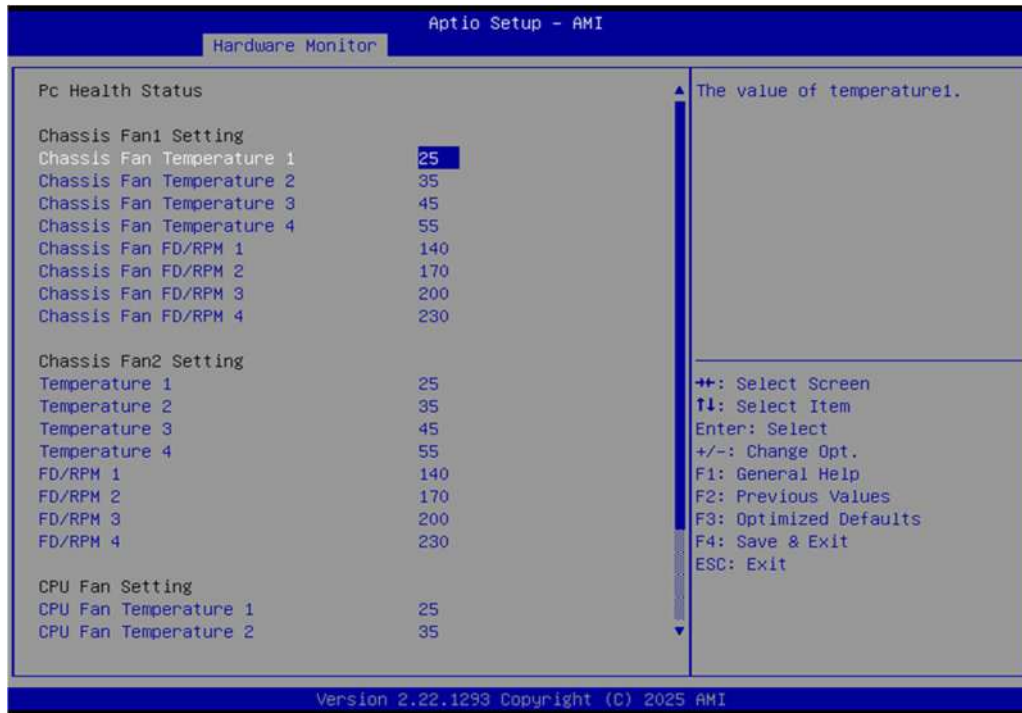

Feature	Description	Options
Chassis Fan Temperature 1	The value of temperature1.	★25
Chassis Fan Temperature 2	The value of temperature2.	★35
Chassis Fan Temperature 3	The value of temperature3.	★45
Chassis Fan Temperature 4	The value of temperature4.	★55
Chassis Fan FD/RPM 1	The value of Fan Duty/RPM when temperature is T1.	★140
Chassis Fan FD/RPM 2	The value of Fan Duty/RPM when temperature is T2.	★170
Chassis Fan FD/RPM 3	The value of Fan Duty/RPM when temperature is T3.	★200
Chassis Fan FD/RPM 4	The value of Fan Duty/RPM when temperature is T4.	★230

Chassis Fan 2 Setting

Feature	Description	Options
Temperature 1	The value of temperature1.	★25
Temperature 2	The value of temperature2.	★35
Temperature 3	The value of temperature3.	★45
Temperature 4	The value of temperature4.	★55
FD/RPM 1	The value of Fan Duty/RPM when temperature is T1.	★140
FD/RPM 2	The value of Fan Duty/RPM when temperature is T2.	★170
FD/RPM 3	The value of Fan Duty/RPM when temperature is T3.	★200
FD/RPM 4	The value of Fan Duty/RPM when temperature is T4.	★230

CPU Fan Setting

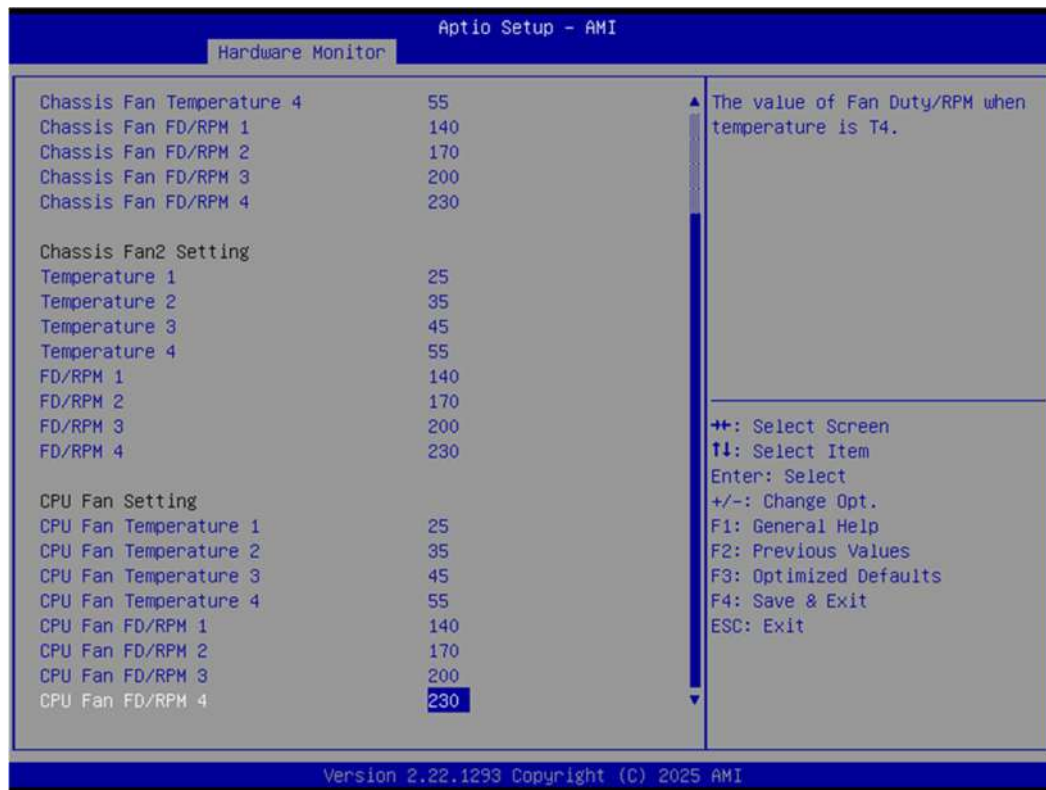

Feature	Description	Options
CPU Fan Temperature 1	The value of temperature1.	★25
CPU Fan Temperature 2	The value of temperature2.	★35
CPU Fan Temperature 3	The value of temperature3.	★45
CPU Fan Temperature 4	The value of temperature4.	★55
CPU Fan FD/RPM 1	The value of Fan Duty/RPM when temperature is T1.	★140
CPU Fan FD/RPM 2	The value of Fan Duty/RPM when temperature is T2.	★170
CPU Fan FD/RPM 3	The value of Fan Duty/RPM when temperature is T3.	★200
CPU Fan FD/RPM 4	The value of Fan Duty/RPM when temperature is T4.	★230

6.5 Security

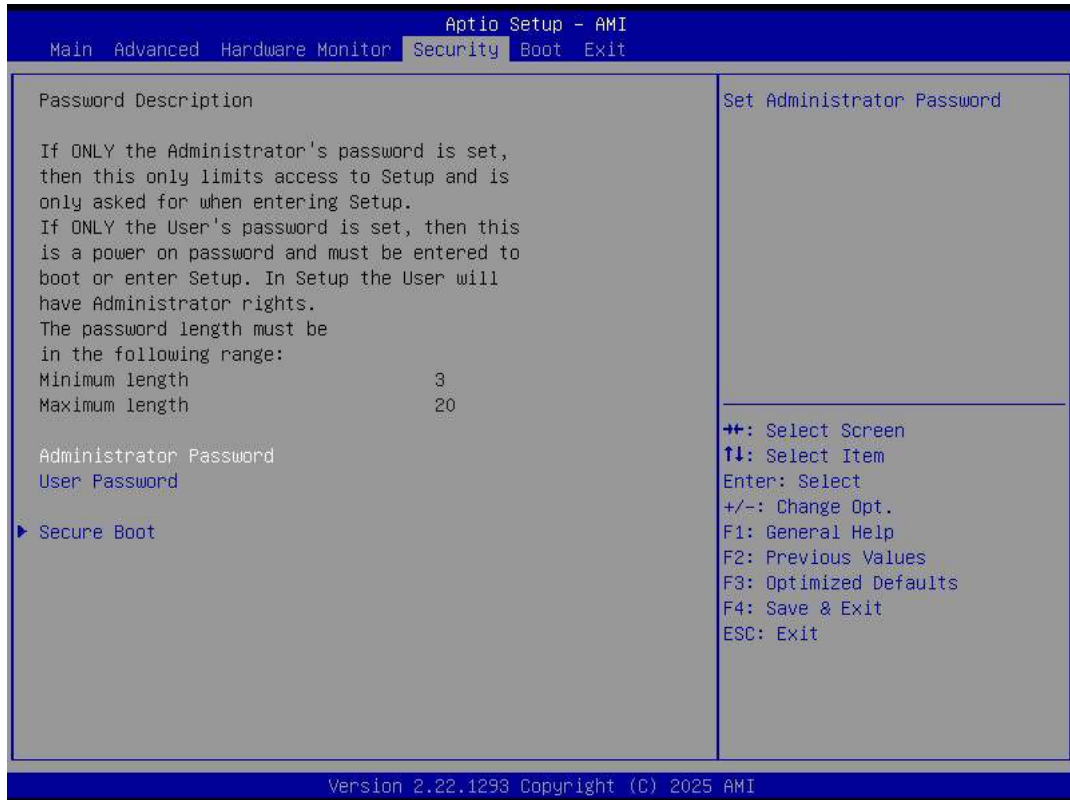

vc	Description	Options
Administrator Password	Set Administrator password	
User Password	Set User Password	
Secure Boot	Secure Boot configuration	

Secure Boot

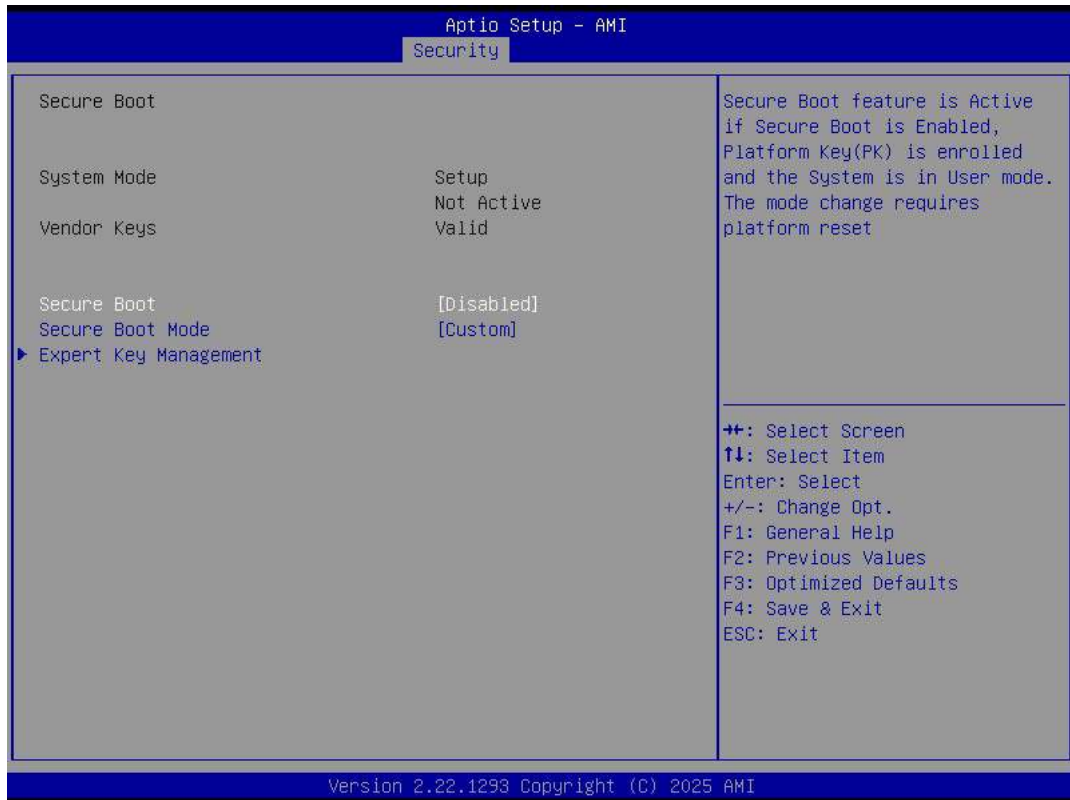

Feature	Description	Options
Secure Boot	Secure Boot feature is Active if Secure Boot is Enabled, Platform Key (PK) is enrolled and the System is in User mode. The mode change requires platform reset	★Disabled, Enabled
Secure Boot Mode	Secure Boot Mode options: Standard or Custom. In Custom mode, Secure Boot Policy variables can be configured by a physically present user without full authentication	Standard, ★Custom
Expert Key Management	Enables expert users to modify Secure Boot Policy variables without variable authentication	

Expert Key Management

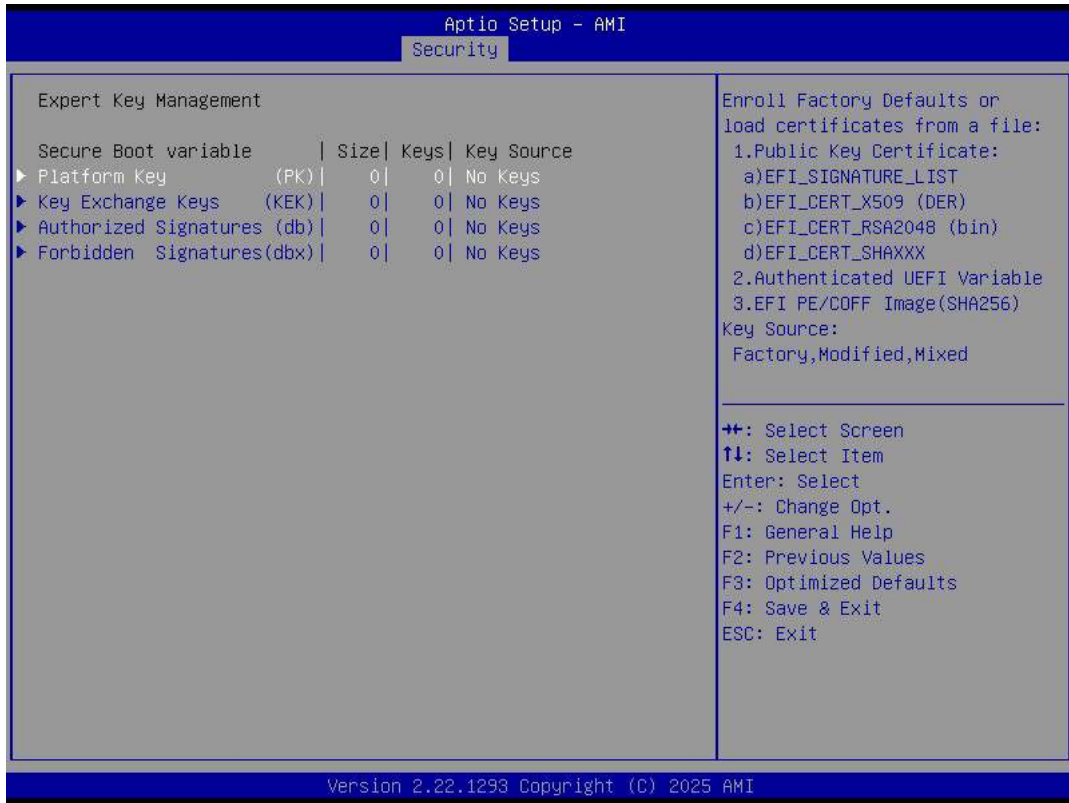

Feature	Description	Options
Platform Key(PK)	Enroll Factory Defaults or load certificates from a file:	Update,
Key Exchange Keys(KEK)	1.Public Key Certificate: a)EFI_SIGNATURE_LIST b) EFI_CERT_X509 (DER) c) EFI_CERT_RSA2048 (bin)	Update, Append,
Authorized Signatures(db)	d)EFI_CERT_SHAXXX 2.Authenticated UEFI Variable 3.EFI PE/COFF Image(SHA256)	Update, Append,
Forbidden Signatures(dbx)	Key Source: Factory, Modified, Mixed	Update, Append,

6.6 Boot

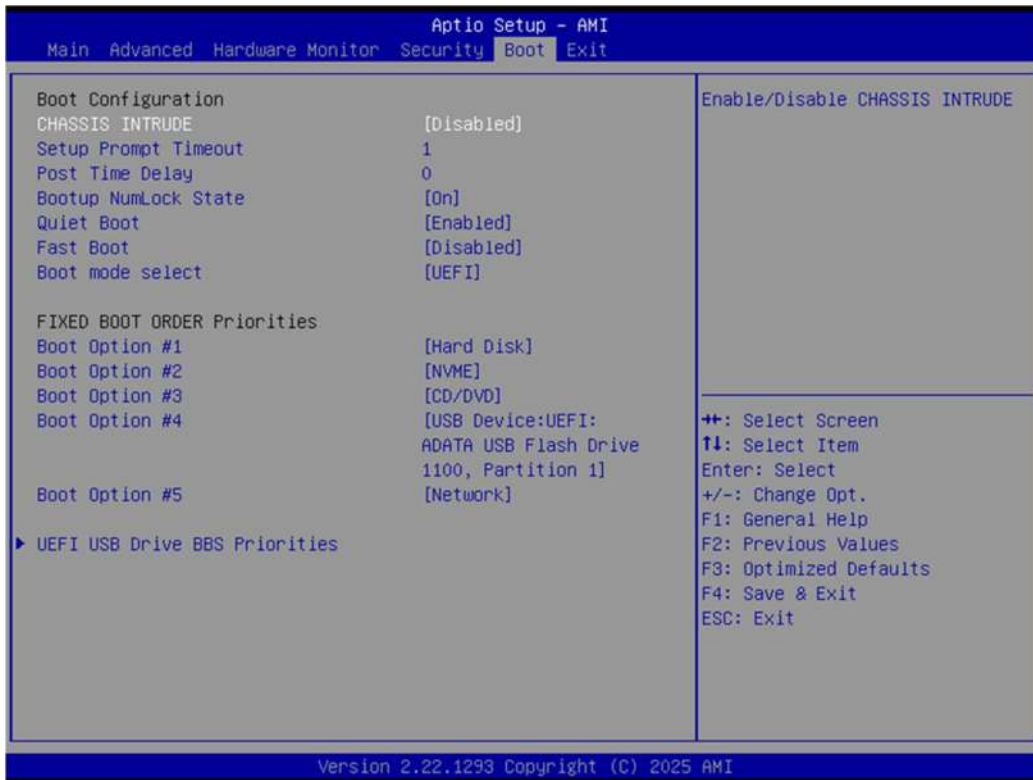

Feature	Description	Options
CHASSIS INTRUDE	Enable/Disable CHASSIS INTRUDE	★Disabled, Enabled
Setup Prompt Timeout	Number of seconds to wait for setup activation key. 65535(0xFFFF) means indefinite waiting.	★1
Post Time Delay	Delay for specific situation needs. For example, HDD spin up time (Delay time = value x 500ms)	★0
Bootup NumLock State	Select the keyboard NumLock state	★On, Off
Quiet Boot	Enables or disables Quiet Boot option	Disabled, ★Enabled
Fast Boot	Enables or disables boot with initialization of a minimal set of devices required to launch active boot option. Has no effect for BBS boot options.	★Disabled, Enabled
Boot mode select	Select boot mode LEGACY/UEFI	★UEFI, LEGACY
Boot Option #1 ~ #5	Sets the system boot order	★Hard Disk, NVME, CD/DVD, Network USB Device, Disabled

UEFI USB Drive BBS Priorities

Specifies the Boot Device Priority sequence from available UEFI USB Drivers.



Feature	Description	Options
CHASSIS INTRUDE	Enable/Disable CHASSIS INTRUDE	★Disabled, Enabled
Setup Prompt Timeout	Number of seconds to wait for setup activation key. 65535(0xFFFF) means indefinite waiting.	★1
Post Time Delay	Delay for specific situation reeds. For example, HDD spin up time (Delay time = value x 500ms)	★0
Bootup NumLock State	Select the keyboard NumLock state	★On, Off
Quiet Boot	Enables or disables Quiet Boot option	Disabled, ★Enabled
Fast Boot	Enables or disables boot with initialization of a minimal set of devices required to launch active boot option. Has no effect for BBS boot options.	★Disabled, Enabled
Boot mode select	Select boot mode LEGACY/UEFI	★UEFI, LEGACY
Boot Option #1 ~ #5	Sets the system boot order	★Hard Disk, NVME, CD/DVD, Network USB Device, Disabled

6.7 Exit

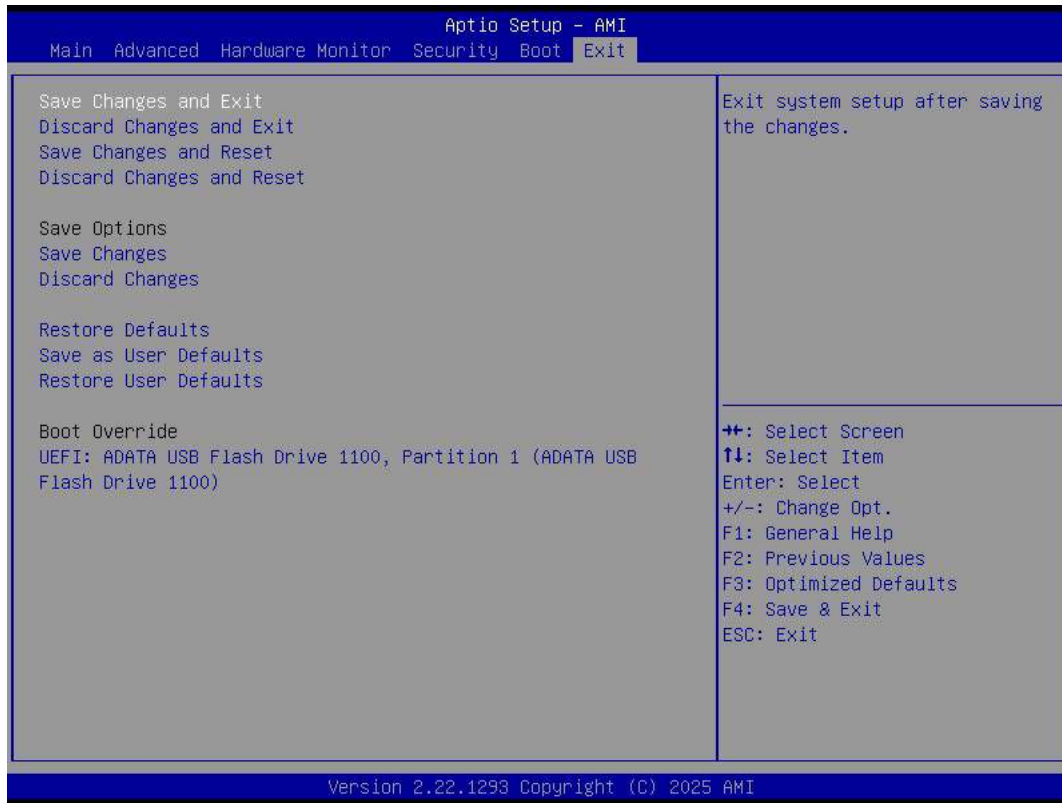

Feature	Description	Options
Save Changes and Exit	Exit system setup after saving the changes.	
Discard Changes and Exit	Exit system setup without saving any changes.	
Save Changes and Reset	Reset the system after saving the changes.	
Discard Changes and Reset	Rest system setup without saving any changes.	
Save Changes	Save Changes done so far to any of the setup options.	
Discard Changes	Discard Changes done so far to any of the setup options.	
Restore Defaults	Restore/Load Default values for all the setup options.	
Save as User Defaults	Save the changes done so far as User Defaults.	
Restore User Defaults	Restore the User Defaults to all the setup options.	

Question: How to update the BIOS file of RUBY-D813-H610E-D5?

Answer:

1. Please visit web site of Portwell download center as below hyperlink
<https://www.portwell.com.tw/support-center/download-center/>
2. Select “Search download” and type the keyword “RUBY-D813-H610E-D5”.
3. Find the “BIOS “page and download the ROM file and unzip file to USB flash drive (FAT 32 formats).
4. Boot into BIOS and switch to “Advanced” page then select”EZ-Flash”.

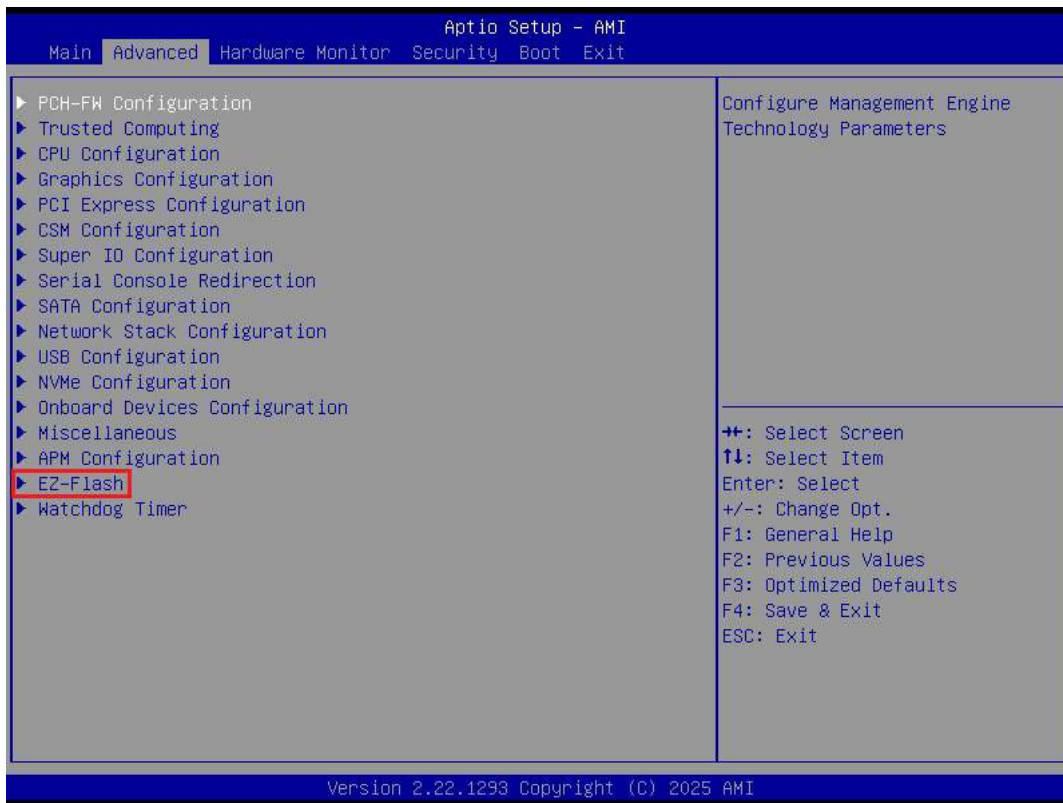

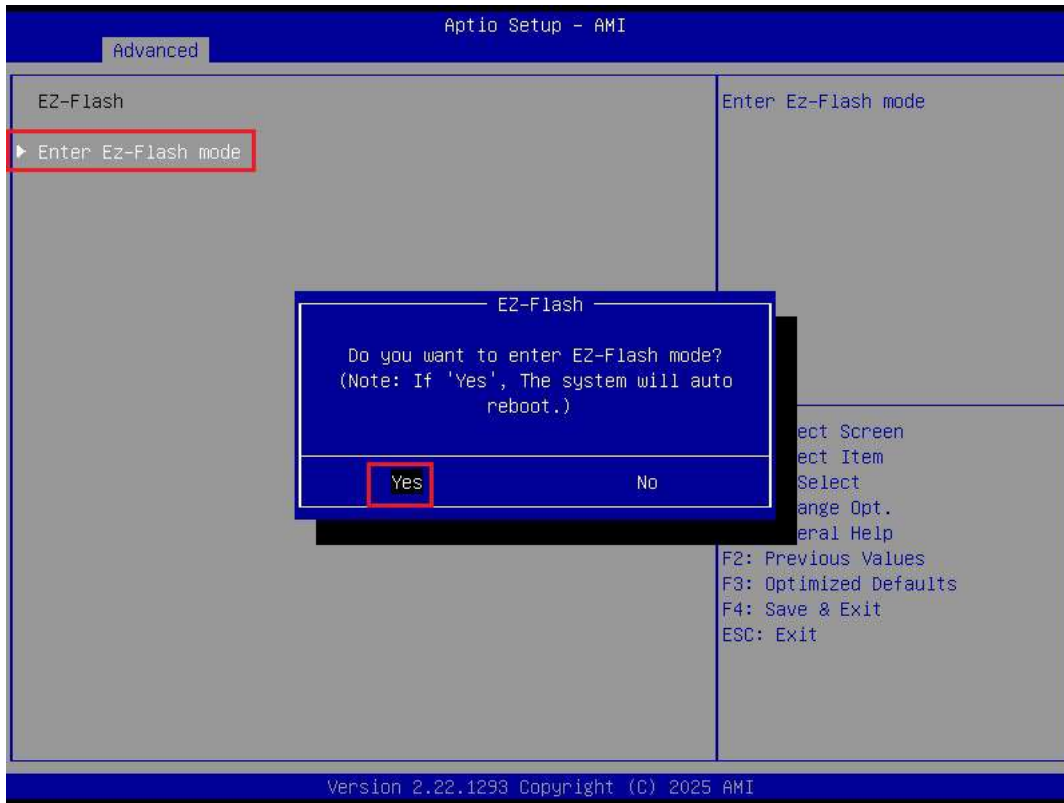

5. Enter EZ-Flash mode, Select the USB Drive and Click the BIOS file then start updating BIOS.

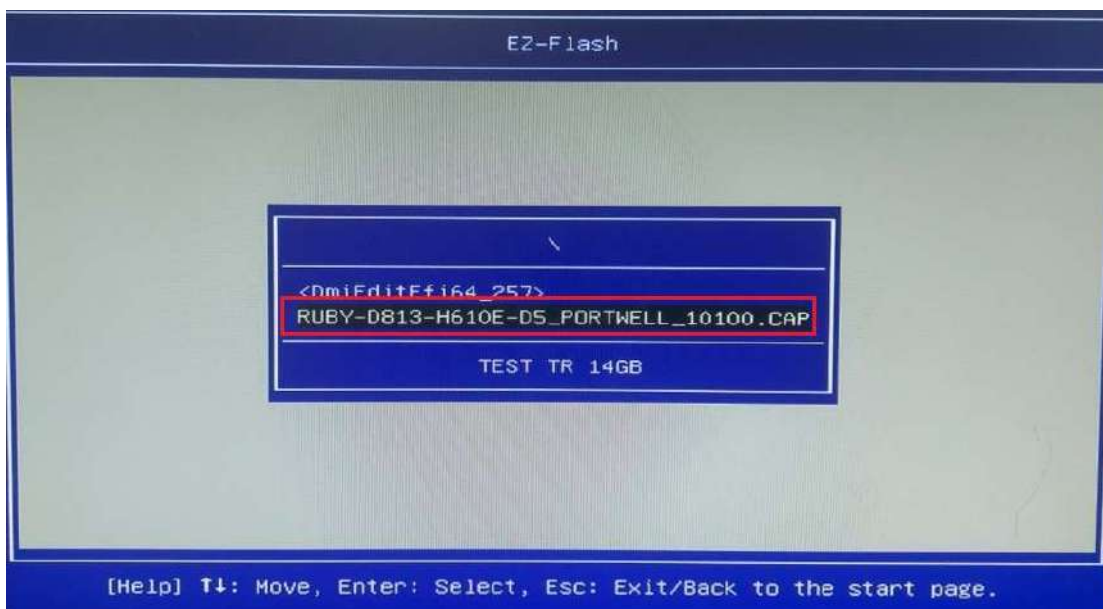

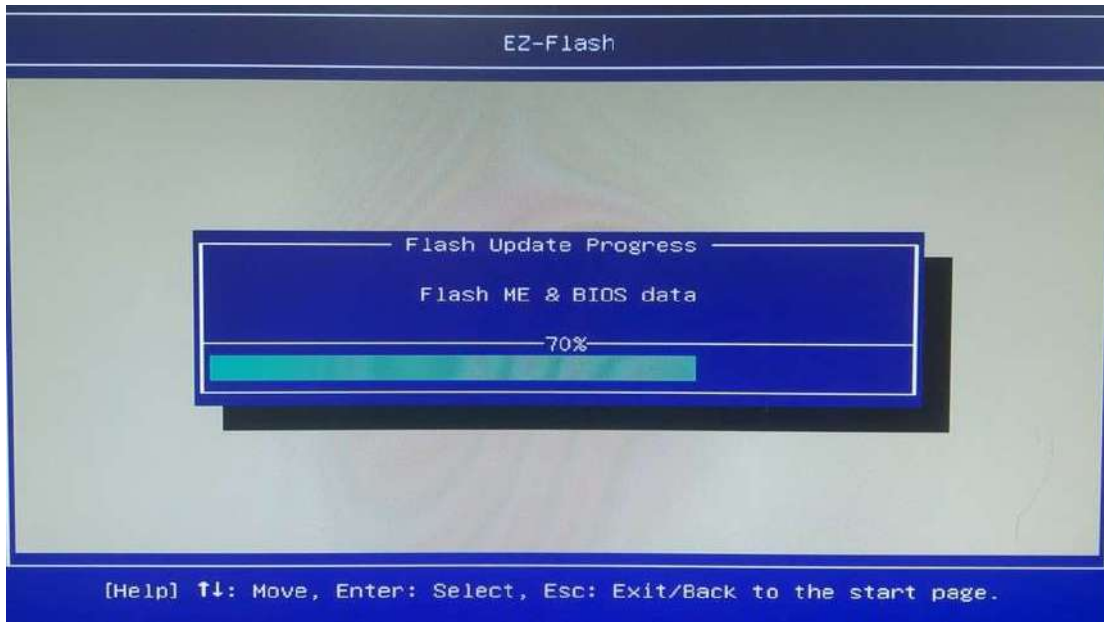

6. When you see the “**BIOS updated successfully**” message, which means the BIOS update processes finished.
Please cut the AC power off and **wait for 10 seconds** before powering on.

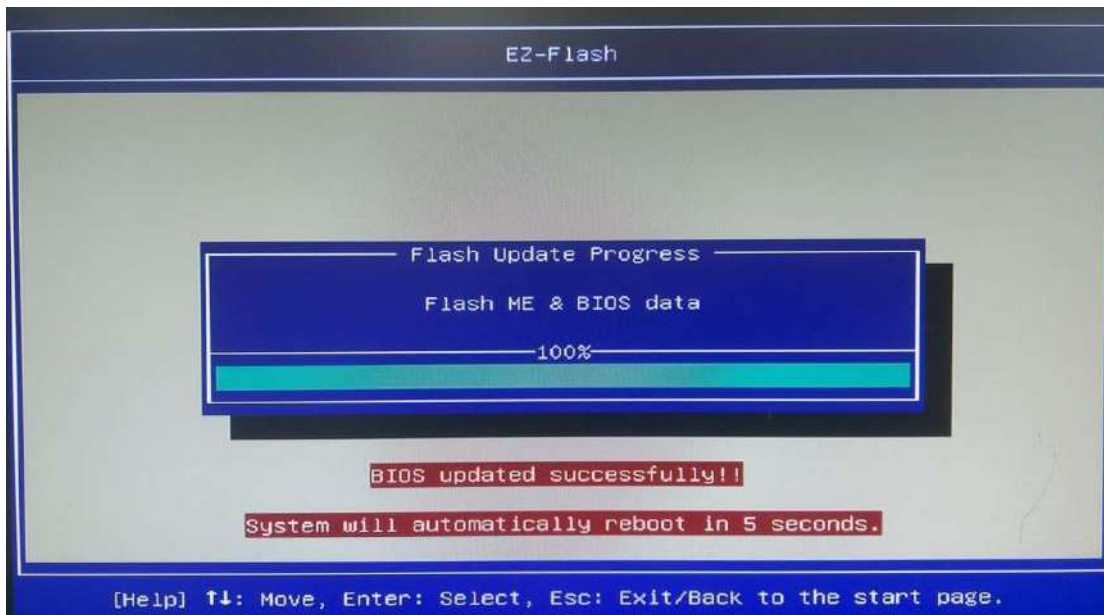

Chapter 7

Overview

- 7 System Resources
- 7.1 Intel® Alder/ Amston Lake SoC
- 7.2 Main Memory
- 7.3 Installing the Single Board Computer

7 System Resources

7.1 Intel PCH

Intel® Q870 Chipset

7.2 Main Memory

RUBY-D814-Q870 provides 4 Dual Channel DDR5 U-DIMMs sockets which support the maximum memory can be up to 192GB. Memory clock and related settings can be detected by BIOS via SPD interface.

Watch out the contact and lock integrity of memory module with socket, it will impact on the system reliability. Follow normal procedures to install memory modules into memory socket. Before locking, make sure that all modules have been fully inserted into the card slots.

7.3 Installing the Single Board Computer

To install your RUBY-D814-Q870 into the standard chassis or proprietary environment, please perform the following:

Step 1: Check all jumpers setting on proper position

Step 2: Install and configure CPU, CPU cooler and memory module on right position

Step 3: Place RUBY-D814-Q870 into the dedicated position in the system

Step 4: Attach cables to existing peripheral devices and secure it

WARNING

Please ensure that the motherboard is properly inserted and fixed by the mechanism.

Note:

Please find drivers in the RUBY-D814-Q870 of Portwell's download center. The driver supports Windows 10/11.

Chapter 8

- 8 Troubleshooting
- 8.1 Hardware Quick Installation
- 8.2 BIOS Setting
- 8.3 FAQ

8 Troubleshooting

This chapter provides a few useful tips to quickly get RUBY-D814-Q870 running with success. As basic hardware installation has been addressed in Chapter 2, this chapter will focus on system integration issues, in terms of BIOS setting, and OS diagnostics.

8.1 Hardware Quick Installation

ATX Power Setting

Correctly orient the ATX power supply plugs into these connectors and push down firmly until the connectors completely fit.

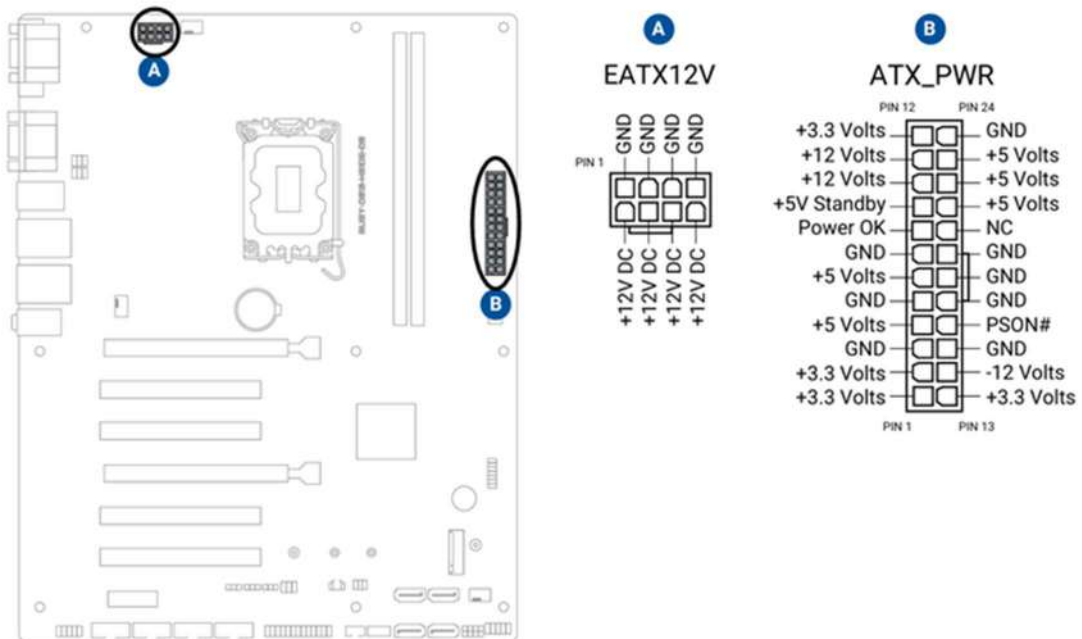

Serial ATA

Serial ATA Hard Disk Setting for SATA Speed Selection

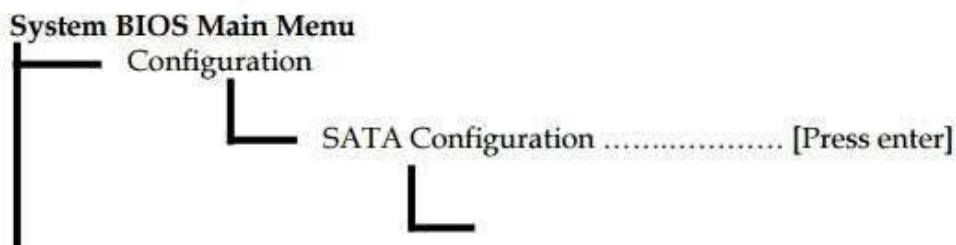
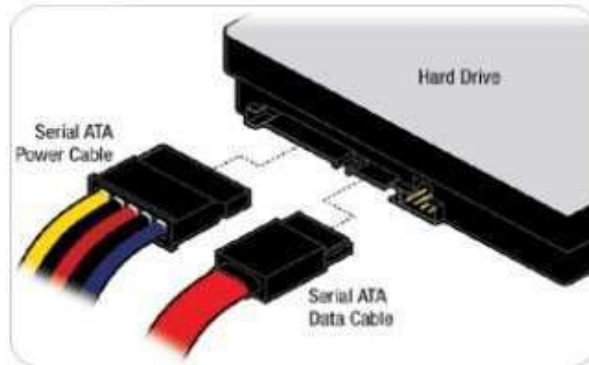

SATA Speed Selection [Auto, Gen1, Gen2, Gen3]

8.2 BIOS Setting

It is assumed that users have correctly adopted modules and connected all the devices cables required before turning on ATX power.

DDR5 UDIMM Memory, keyboard, mouse, SATA hard disk, VGA connector, device power cables, ATX accessories are good examples that deserve attention. With no assurance of properly and correctly accommodating these modules and devices, it is very possible to encounter system failures that result in malfunction of any device.

To make sure that you have a successful start with RUBY-D813-H610E-D5, it is recommended, when going with the boot-up sequence, to hit “DEL” and” ESC” key and enter the BIOS setup menu to tune up a stable BIOS configuration so that you can

wake up your system far well.

Loading the default optimal setting

When prompted with the main setup menu, please scroll down to “**RestoreDefaults**”, press “**Enter**” and select “**Yes**” to load default optimal BIOS setup. This will force your BIOS setting back to the initial factory configurations. It is recommended to do this so you can be sure the system is running with the BIOS setting that Portwell has highly endorsed. As a matter of fact, users can load the default BIOS setting at any time when system appears to be unstable in boot up sequence.

8.3 FAQ

Information & Support

Question: I forgot my password for system BIOS, what am I supposed to do?

Answer: You can switch off your power supply then find the RTC battery on the RUBY-D813-H610E-D5. Then remove the RTC battery and wait 5 seconds to clean your password then to switch on your power supply.

Question: How to update the BIOS file of RUBY-D814-Q870?

Answer:

1. Please visit web site of Portwell download center as below hyperlink <https://download.portwell.tw/>
2. Select “Search download” and type the keyword “RUBY-D813-H610E-D5”.
3. Find the “BIOS “page and download the ROM file and flash utility.
4. Unzip file to bootable USB flash drive which can boot to shell mode. Then execute the “update.efi”. It will start to update BIOS.
5. When you see the “FPT Operation Passed” message, which means the BIOS update processes finished. Please cut the AC power off and wait for 10 seconds before powering on.
6. If you have other additional technical information or requests which are not covered in this manual, please fill in the technical request form as below hyperlink.
<https://www.portwell.com.tw/support-center/technical-request/>
We will do our best to provide a suggestion or solution for you.

Chapter 9

9 Portwell Software Service

RUBY-D814-Q870 user manual

9 Portwell Software Service

Portwell Evaluation Tool (PET)

The Portwell Evaluation Tool (PET) is an API which Portwell's customers can access the GPIO, I2C, SMBus, etc under Windows and Linux OS. For more information, please contact Portwell.

Portwell

Please verify specifications before quoting. This guide is intended for reference purposes only. All product specifications are subject to change without notice. No part of this publication may be reproduced in any form or by any means, such as electronically, by photocopying, recording, or otherwise, without prior written permission from the publisher. All brand and product names are trademarks or registered trademarks of their respective companies.

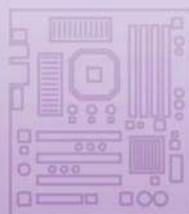
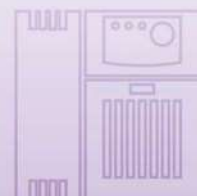

Portwell, Inc. Headquarters

No. 242, Bo'AI St., Shu-Lin Dist,
New Taipei City 238, Taiwan
Tel: +886-2-7731-8888
Fax: +886-2-7731-9888
E-mail: info@portwell.com.tw
www.portwell.com.tw

American Portwell

(Fremont, CA)
Tel: +1-510-403-3399
E-mail: info@portwell.com
www.portwell.com

Portwell UK Ltd.

Tel: +44(0)1235-750-760
E-mail: info@portwell.eu
www.portwell.eu

Portwell Japan, Inc.

(Tokyo)
Tel: +81-3-6902-9225
E-mail: info@portwell.co.jp
www.portwell.co.jp

Portwell Japan, Inc.

(Osaka)
Tel: +81-6-4807-7721
E-mail: info@portwell.co.jp
www.portwell.co.jp

European Portwell

Tel: +31-262-620790
E-mail: info@portwell.eu
www.portwell.eu

KIOSK Embedded

Systems GmbH
Tel: +49-8152-3962-500
E-mail: info@portwell.eu
www.portwell.de

Shanghai Portwell

Tel: +86-21-5771-2505
E-mail: info@portwell.com.cn
www.portwell.com.cn

Portwell Korea, Inc.

Tel: +82-31-450-3043
E-mail: info@portwell.co.kr
www.portwell.co.kr

Portwell India Technology Private Limited

Tel: +91-90-4168-4255
E-mail: enquiry@portwell.in
www.portwell.in