

### FEATURES

- 18.5 "true color LED display with a resolution of 1920\*1080 and a backlight life of up to 50,000 hours.
- The front panel achieves IP65 protection level to prevent dust and spattered water droplets from entering the display.
- The ultra-thin design saves cabinet space and is resistant to shock and vibration.
- 12V DC power input, meets the industrial site power supply.
- High-precision capacitive touch screen, with many industrial site application features, while supporting panel embedded and standard VESA installation, users can flexibly choose the installation method.

### IMAGES



Above image is for representation purpose only. Real unit might look different

### SPECIFICATIONS

Processor	<b>Intel® Core™ i5-7200U Processor</b>
Memory	16GB DDR4
OS	<b>Windows 10 Pro</b>
Storage	1TB SSD
Display	1*HDMI/1*VGA
I/O	4*USB, 2*RJ45, 6*Comm
Audio	1*Line-out /1*Mic-in
Screen Size	<b>18.5"LCD TFT with LED Backlight</b>
Resolution	1920*1080 (16:9 aspect ratio)
Brightness	350cd/m2
Contrast	800:1
Maximum color	16M
Touch Screen	<b>PCAP Touch</b>
Click Life	50 million times
Response time	<5ms
High temperature test	65°C/100hrs
Constant temperature and humidity test	85°C/90%RH/1000hrs
Panel cabinet	Enclosure is aluminum alloy mold
Power input	12V DC power supply (AC~DC external adapter)
Overall dimensions	464mm*288mm*57mm
Installation method	The panel is flush-embedded and mountable with a bracket
Power	20W
Weight	Approx 5.5kg
Operating temperature	-10~60°C (Electronic disk)
Storage temperature	-20~80°C
Correlated humidity	10~95%@40°C (Non-condensing)
Front panel protection	IP65 standard

### Mechanical drawing

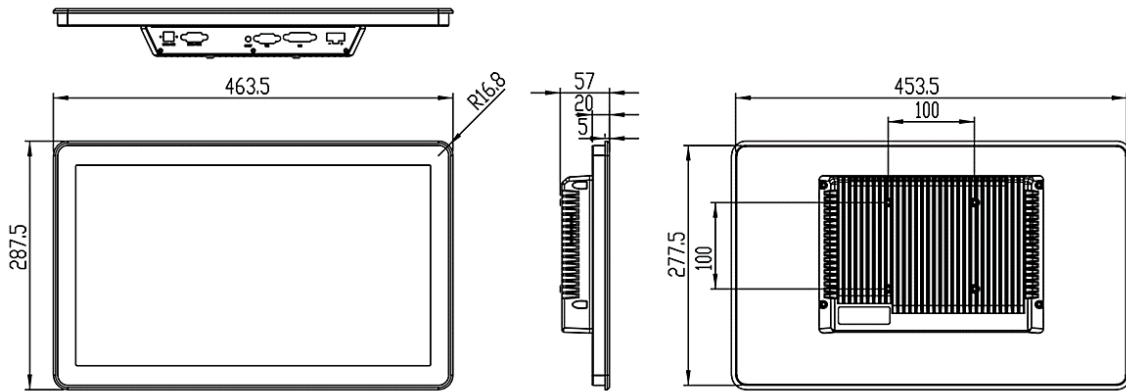

Hole size: (mm)

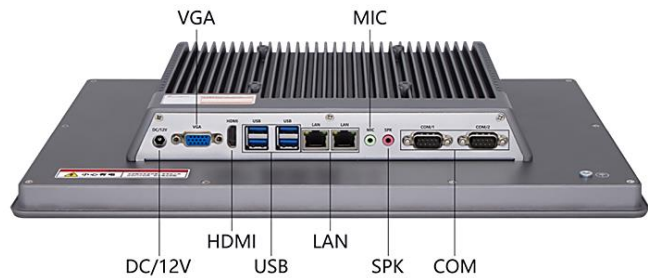
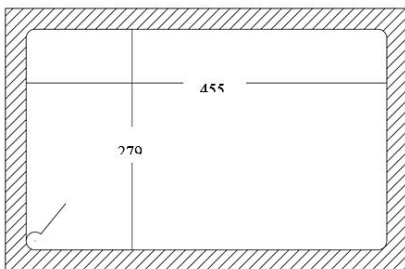

#### Contact :

#### Portwell India Technology Pvt Ltd

7/3 3<sup>rd</sup> Floor, Jeet Dynasty, Swami Vivekananda Road,

Nagavarapalya, Bangalore 560093. Karnataka, IN

Call : +91 80 40782700.

Web : [www.portwell.in](http://www.portwell.in) Mail : [enquiry@portwell.in](mailto:enquiry@portwell.in)

