

COM Express™
PCOM-B880VG2
User's Guide R0.1

Revision History

Rev.	Note	Date
R0.1	Preliminary release	2022 / 11 / 10
R0.2	Update mechanical dimension figures	2023 / 01 / 03

Contents

1	Introduction	9
1.1	PCOM-B880VG2 SKU List.....	10
2	Block Diagram	12
3	Specifications.....	13
3.1	Supported Operating Systems	15
3.2	Windows OS Driver	16
3.3	Electrical Characteristics	17
3.4	Power Consumption	21
3.5	Mechanical Dimensions.....	24
3.6	Environmental Specifications.....	26
3.7	Ordering Guide.....	27
4	Thermal Solution	28
5	Pin out Tables	31
6	System Resources.....	36
7	BIOS Setup Items	37
7.1	Introduction.....	37
7.2	BIOS Setup	38
7.2.1	Main.....	39
7.2.2	Configuration.....	40
7.2.3	Security	67
7.2.4	Boot	68
7.2.5	Save & Exit.....	70
8	BIOS / EC Update.....	71
9	PORTWELL Software Tool	79
10	Packaging Information	80

11 Industry Specifications 81

List of Tables

Table 1 PCOM-B880VG2 CPU Support List.....	10
Table 2 PCOM-B880VG2 Module SKU	11
Table 3 PCOM-B880VG2 SPEC	14
Table 4 OS Support list.....	15
Table 5 Electrical characteristics	17
Table 6 PCOM-B880VG2 Power Consumption List 1.....	22
Table 7 PCOM-B880VG2 Power Consumption List 2.....	23
Table 8 Environmental Specifications.....	26
Table 9 Ordering Guide - PCOM-B880VG2.....	27
Table 10 Ordering Guide - Accessory.....	27
Table 11 Pin out description	35
Table 12 System Resources.....	36
Table 13 Packaging information	80

List of Figures

Figure 1 Block Diagram.....	12
Figure 2 PCOM-B880VG2 Power on sequence	17
Figure 3 Input Power Sequencing	19
Figure 4 Mechanical Dimension - Top	24
Figure 5 Mechanical Dimension - Bottom.....	25
Figure 6 Cooler 125W mechanical dimension.....	28
Figure 7 Cooler 80W mechanical dimension.....	29
Figure 8 Cooler 35W mechanical dimension.....	30

Disclaimer

Warranty

PORTWELL tries to procure that this user manual and our product features are correct and reliable, but in any condition, PORTWELL provides no express or implied warranty and guaranty regard to this user manual or any other product information.

PORTWELL shall not be liable for loss of revenues or profits, inconveniences, expense for substitute equipment or service, storage charges, loss or corruption of data, or any other special, incidental or consequential damages caused by the use or misuse of or inability to use the PORTWELL products, regardless of the legal theory on which the claim is based, and even if PORTWELL has been advised of the possibility of such damages.

The information contained within this user manual, including but not limited to any other product specification, PORTWELL reserves its right to modify them at any time without notice.

Trademarks

All product names, logos, brands, trademarks and registered trademarks in this user's manual or the PORTWELL website are the property of their respective owners.

Certification

PORTWELL is certified to ISO 9001:2008 standard.



Technical Support

PORTWELL technicians and engineers are committed to providing the best possible technical support for our customers so that our products can be easily used and implemented.

We request that you first visit our website at <http://www.PORTWELL.com.tw/support/> for the latest documentation, utilities and drivers, which have been made available to assist you. If you still require assistance after visiting our website, you can contact our technical support department by email at tsd@mail.PORTWELL.com.tw for further assistance.

1 Introduction

PCOM-B880VG2 is Intel® Comet Lake-S platform COM-HPC® Client, Size C module. The COM-HPC® Client Formfactor support more I/O interface and power for desktop level socket type CPU for wider computing demand applications. The desktop CPU on module offers customer higher computing power but lower cost comparing to mobile solutions. PCOM-B880VG2 supports both ECC and Non-ECC DDR4 by different PCH SKUs (Q470E/W480E), which can be adapted to different applications. This module provides one PCIe x16, four USB 3.2 Gen2, two SATA III, PCIe storage and up to 20 PCIe x1 lanes.

1.1 PCOM-B880VG2 SKU List

PCOM-B880VG2										
COM HPC Client Size C										
CPU SKU	TDP	Core	Threads	Cache	Base Freq	Max Turbo Freq	Max Memory MT/s	W480E	Q470E	ECC
Xeon W-1250E	80W	6	12	12MB	3.5GHz	4.7GHz	2933 MT/s	Yes	No	Yes
Xeon W-1290TE	35W	10	20	20MB	1.8GHz	4.5GHz				
Xeon W-1270TE	35W	8	16	16MB	2.0GHz	4.4GHz				
Xeon W-1250TE	35W	6	12	12MB	2.4GHz	3.8GHz				
i9-10900TE	35W	10	20	20MB	1.8GHz	4.5GHz	2666 MT/s	Yes	Yes	No
i7-10700TE	35W	8	16	16MB	2.0GHz	4.4GHz				
i5-10500E	65W	6	12	12MB	3.1GHz	4.2GHz				
i5-10500TE	35W	6	12	12MB	2.3GHz	3.7GHz				
i3-10100E	65W	4	8	6MB	3.2GHz	3.8GHz	2666 MT/s	Yes	Yes	Yes
i3-10100TE	35W	4	8	6MB	2.3GHz	3.6GHz				
Pentium G6400E	65W	2	4	4MB	3.8GHz	3.8GHz	2400 MT/s	No	No	No
Pentium G6400TE	35W	2	4	4MB	3.2GHz	3.2GHz				
Celeron G5900E	65W	2	2	2MB	3.2GHz	3.2GHz				
Celeron G5900TE	35W	2	2	2MB	3.0GHz	3.0GHz				

Table 1 PCOM-B880VG2 CPU Support List

Series	PCOM-B880VG2		
Ordering P/N	AB1-3L36	AB1-3L35	
<u>CPU/PCH Specifications</u>			
Processor	Socket Type	Socket Type	
PCH	W480E	Q470E	
TDP Range	35 ~ 80 W	35 ~ 80 W	
Temperature Range	0 °C ~ 60 °C	0 °C ~ 60 °C	
<u>Memory Specifications</u>			
Capacity	2x SO-DIMM (64GB)	2x SO-DIMM (64GB)	
Speed	3200 Mhz	3200 Mhz	
ECC	Yes (Depend on CPU)	No	
<u>I/O Specifications</u>			
PCIe	PEG (Gen3 x16) 8x PCIe 3.0 x1 3x PCIe 3.0 x4	PEG (Gen3 x16) 8x PCIe 3.0 x1 3x PCIe 3.0 x4	
USB 3.2 Gen2 /2.0	4x / 8x	4x / 8x	
SATA	2x	2x	
Ethernet	2x 2.5 GbE	2x 2.5 GbE	

Table 2 PCOM-B880VG2 Module SKU

2 Block Diagram

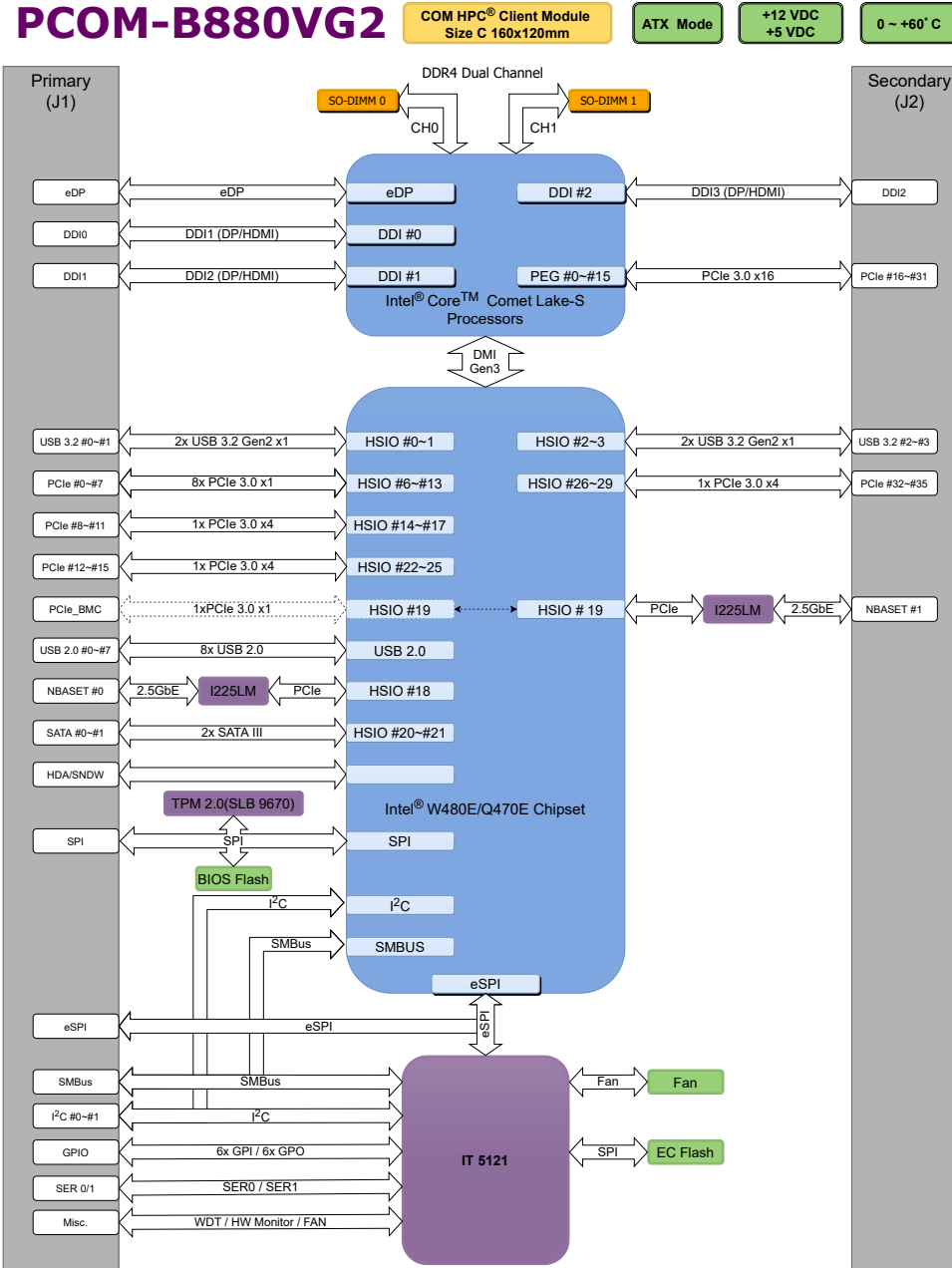

Figure 1 Block Diagram

3 Specifications

Product	➤ PCOM-B880VG2
Form Factor	➤ COM-HPC® Client, Size C (160 X 120mm)
Processor	<ul style="list-style-type: none"> ➤ Intel® Xeon® W-1250E ➤ Intel® Xeon® W-1290TE ➤ Intel® Xeon® W-1270TE ➤ Intel® Xeon® W-1250TE ➤ Intel® Core™ i9-10900TE ➤ Intel® Core™ i7-10700TE ➤ Intel® Core™ i5-10500E ➤ Intel® Core™ i5-10500TE ➤ Intel® Core™ i3-10100E ➤ Intel® Core™ i3-10100TE ➤ Intel® Pentium® G6400E ➤ Intel® Pentium® G6400TE ➤ Intel® Celeron® G5900E ➤ Intel® Celeron® G5900TE
BIOS	➤ AMI BIOS
Memory	<ul style="list-style-type: none"> ➤ 2x SO-DIMM DDR4 ➤ Support ECC (selected SKU) ➤ Up to 64GB 3200MHz
Graphic	➤ Depend on CPU (Intel® UHD Graphics 600 series)
Ethernet	➤ 2x 2.5 GbE (via Intel® i225LM)
Audio	➤ HDA

PCI Express	<ul style="list-style-type: none"> ➤ PEG (Group 1, PCIe 3.0 x16) ➤ 8x Gen3 x1 (Group 0 Low) ➤ 2x Gen3 x4 (Group 0 High) ➤ 1x Gen3 x4 (Group 2, #32 ~ #35)
I/O	<ul style="list-style-type: none"> ➤ 4x USB 3.2 Gen2 ➤ 8x USB 2.0 ➤ 2x SATA ➤ 12 bit GPIO (default 6 in / 6 out) ➤ I2C / SMBus ➤ 2x UART
Hardware Monitors	➤ ITE series Embedded Controller, Voltage, Fan and Temperature
Security	➤ TPM 2.0 (Option)
Power Management	➤ ACPI
Environment	<ul style="list-style-type: none"> ➤ Operating Temperature 0 °C ~ 60 °C ➤ Storage Temperature -40 °C ~ 85 °C ➤ Relative Humidity 5% ~ 95%

Table 3 PCOM-B880VG2 SPEC

3.1 Supported Operating Systems

The PCOM-B880VG2 supports the following operating systems.

Vendor	Operating System	Implementation
Microsoft	Windows 10 IoT Enterprise RS5	Intel
	Windows Server 2019 (Xeon W Only)	Intel
Linux	Ubuntu	Canonical Ltd.
	SuSe	Attachmate Grp
	Redhat Enterprise	Red Hat
	Wind River Linux	Wind River Systems
	Yocto Project BSP	Intel

Table 4 OS Support list

Note. Portwell does not endorse/validate/support any specific Linux distribution or entity mentioned on this list.

Note. Portwell recommends customers to work with Linux vendors/open source communities to find feature list and support model.

3.2 Windows OS Driver

Please download the drivers from Portwell download center website http://www.portwell.tw/support/download_center.php

3.3 Electrical Characteristics

Input voltage	+12V \pm 5%
RTC Battery	From Carrier
Power on mode	ATX Mode & AT Mode

Table 5 Electrical characteristics

Power Distribution

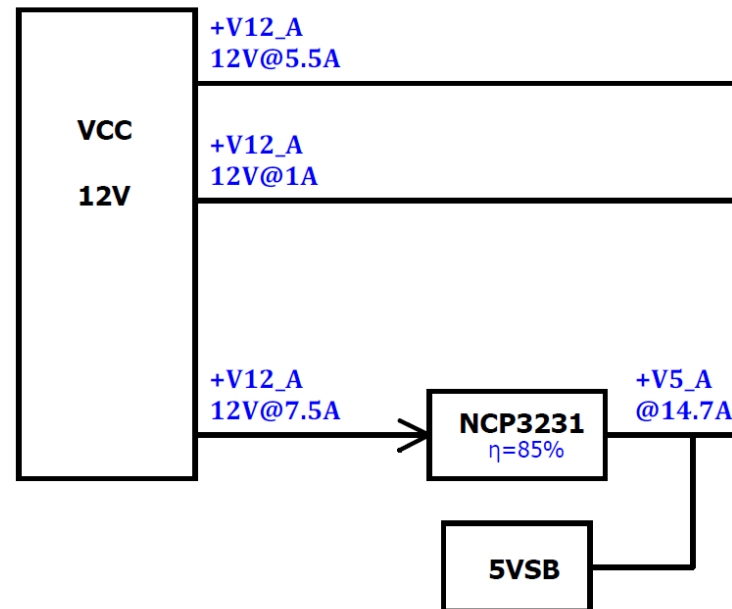

Figure 2 PCOM-B880VG2 Power on sequence

- Input Power Sequencing

COM-HPC input power sequencing requirements are as follows:

- VCC_RTC should come up at the same time or before VCC_5V_SBY comes up
- VCC_5V_SBY should come up at the same time or before VCC comes up
- RSMRST_OUT# should come up when the Module standby rail(s) are stable
- VIN_PWR_OK should be active after VCC is stable
- VIN_PWR_OK should be inactive at the same time or before VCC goes down
- VCC should go down at the same time or before VCC_5V_SBY goes down
- VCC_5V_SBY should go down at the same time or before VCC_RTC goes down

T1	VCC_RTC rise to VCC_5V_SBY rise	≥ 0 ms
T2	VCC_5V_SBY rise to VCC_12V rise	≥ 0 ms
T3	VCC rise to 95% of nominal value to VIN_PWR_OK rise	≥ 0 ms
T4	VIN_PWR_OK fall to VCC_12V fall (90%)	≥ 0 ms
T5	VCC fall to VCC_5V_SBY fall	≥ 0 ms
T6	VCC_5V_SBY fall to VCC_RTC fall	≥ 0 ms

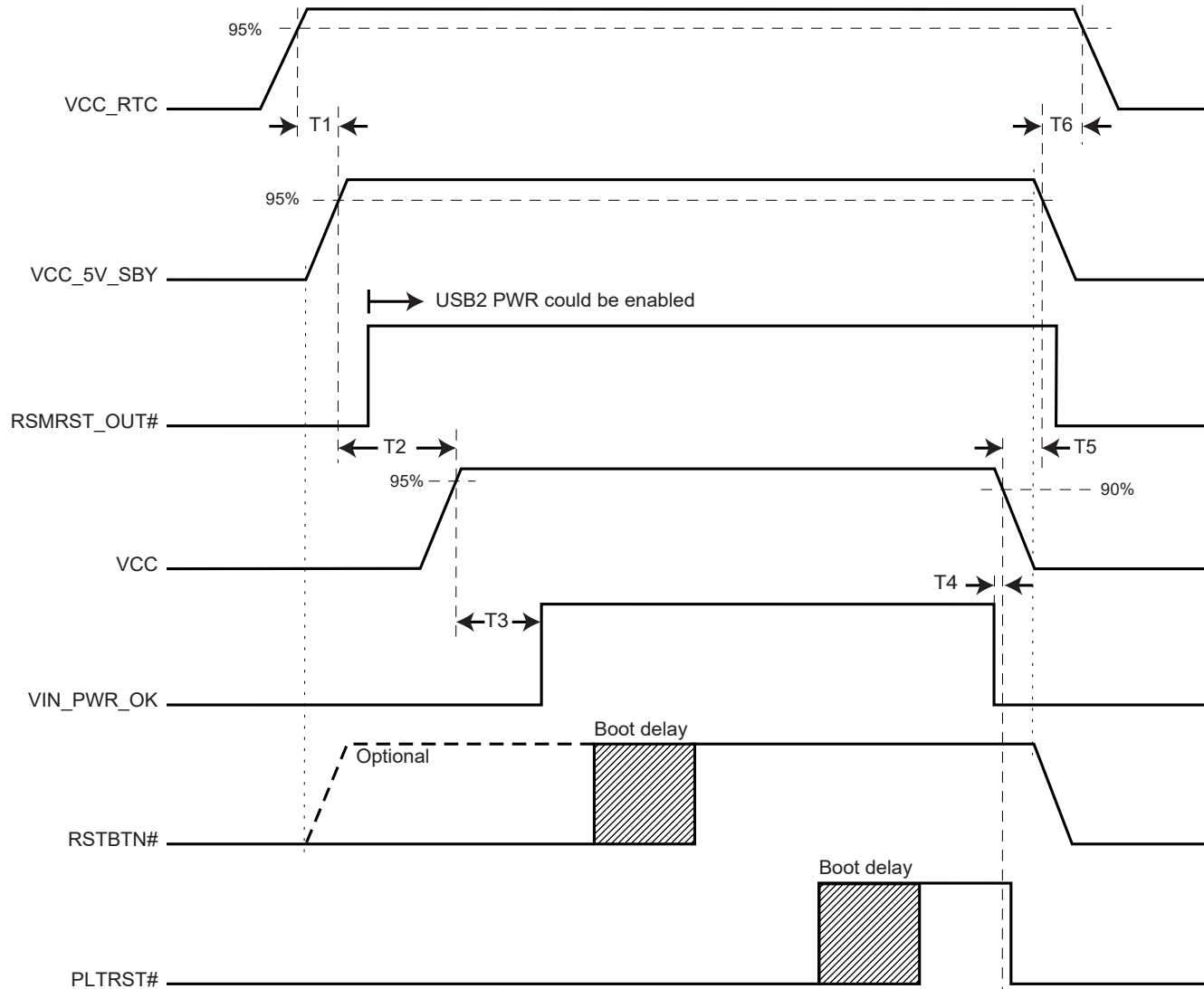

Figure 3 Input Power Sequencing
 (Reference from COM-HPC® Module Base Specification)

- Power signals

Signals VIN_PWR_OK, RSTBTN#, and PLTRST# shall be supported for all COM-HPC Modules. Signal VIN_PWR_OK indicates that all the power to the Module is stable within the specified range and can be used to enable Module internal power supplies.

On COM Express designs, the VIN_PWR_OK line is used to hold off a CPU boot to allow off Module devices such as large FPGAs enough time to be configured. This method should not be used on COM-HPC designs. An alternative method, pausing the Module boot by BIOS code monitoring the RSTBTN# signal.

Some input signals such as PWRBTN# and RSTBTN# may require debounce and ESD protection components on the Carrier board. Please refer to the COM-HPC Carrier Board Design Guide for details.

3.4 Power Consumption

The power consumption values were measured with the following condition:

- ATX power supply
- PCOM-B880VG2 module
- PCOM-C880 carrier
- PCOM-B880VG2 standard cooler
- Windows 10 IoT Enterprise LTSC

The power consumption values were recorded during the following methods:

- S0 Idle: 12v current, boot into Windows desktop and idle for 5 min
- 100% Workload with turbo: The average 12v current during 100% workload
- Peak Current: The maximum 12v current during the beginning of turbo mode running
- S3: 5v standby current, wait 5 min later after system into sleeping status
- S5: 5v standby current, wait 5 min later after system into shutdown status

Note. Power consumption results are measured at Portwell laboratory and are for reference only

- CPU SKU 1

Series	PCOM-B880VG2					
Processor	Xeon W-1250E	Xeon W-1290TE	Xeon W-1270TE	Xeon W-1250TE	i9-10900TE	i7-10700TE
Cores / Threads	6 / 12	10 / 20	8 / 16	6 / 12	10 / 20	8 / 16
TDP	80W	35W	35W	35W	35W	35W
<u>Power Consumption</u>						
S0 Idle	TBD	TBD	TBD	TBD	TBD	TBD
100% Workload with turbo mode	TBD	TBD	TBD	TBD	TBD	TBD
Peak Current	TBD	TBD	TBD	TBD	TBD	TBD
S3	TBD	TBD	TBD	TBD	TBD	TBD
S5	TBD	TBD	TBD	TBD	TBD	TBD

Table 6 PCOM-B880VG2 Power Consumption List 1

- CPU SKU 2

Series	PCOM-B880VG2					
Processor	i5-10500E	i5-10500TE	i3-10100E	i3-10100TE	Pentium G6400E	Pentium G6400TE
Cores / Threads	6 / 12	6 / 12	4 / 8	4 / 8	2 / 4	2 / 4
TDP	65W	35W	65W	35W	65W	35W
<u>Power Consumption</u>						
S0 Idle	TBD	TBD	TBD	TBD	TBD	TBD
100% Workload with turbo mode	TBD	TBD	TBD	TBD	TBD	TBD
Peak Current	TBD	TBD	TBD	TBD	TBD	TBD
S3	TBD	TBD	TBD	TBD	TBD	TBD
S5	TBD	TBD	TBD	TBD	TBD	TBD

Table 7 PCOM-B880VG2 Power Consumption List 2

3.5 Mechanical Dimensions

● Top Side Dimension

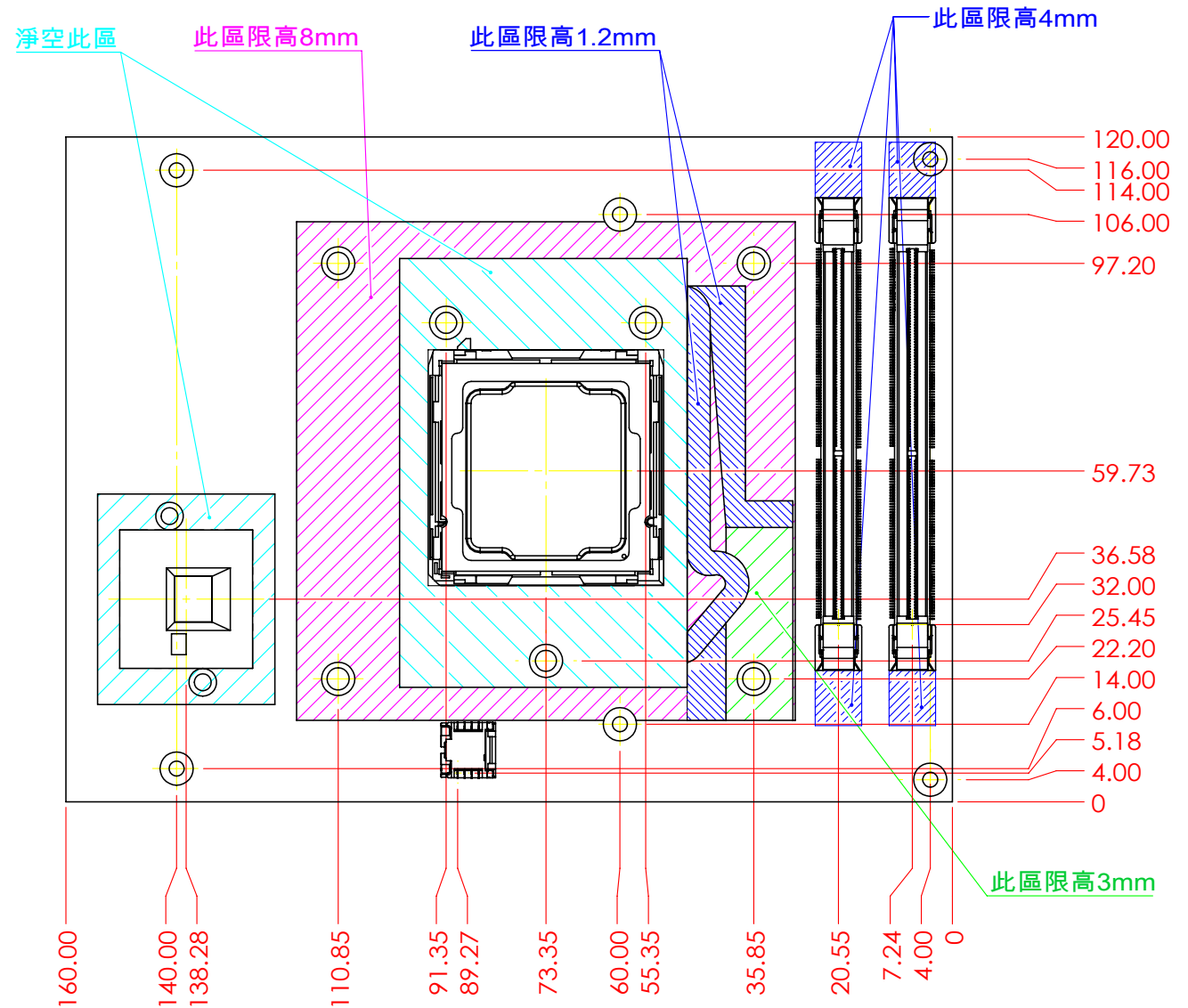

Figure 4 Mechanical Dimension - Top

● Bottom Side Dimension

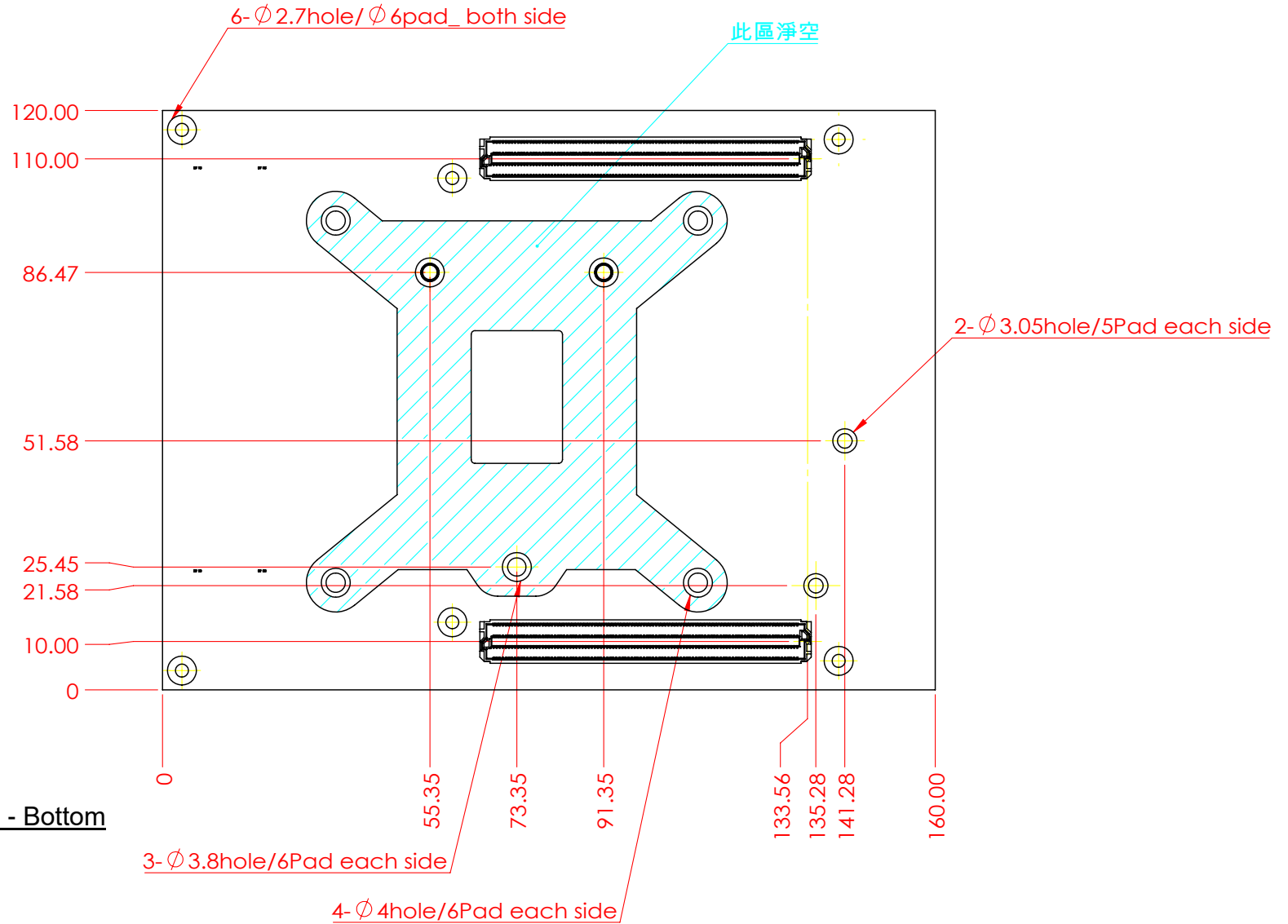

Figure 5 Mechanical Dimension - Bottom

3.6 Environmental Specifications

Storage Temperature	-40°C ~ 85°C
Operation Temperature	0°C ~ 60°C
Storage Humidity	0% ~ 95%
Operation Humidity	0% ~ 95%

Table 8 Environmental Specifications

3.7 Ordering Guide

◆ Module

Product	Ordering P/N
PCOM-B880VG2-W480E	AB1-3L36
PCOM-B880VG2-Q470E	AB1-3L35

Table 9 Ordering Guide - PCOM-B880VG2

◆ Accessory

Accessory	Ordering P/N	Remark
Cooler 125W	B9971030	For 80W+ CPU
Cooler 80W	B9971060	For 80W CPU
Cooler 35W	B8304610	For 35W CPU
Evaluation Carrier (ATX) PCOM-C880	AB1-3L34Z	In Development

Table 10 Ordering Guide - Accessory

4 Thermal Solution

- Cooler 125W (B9971030)

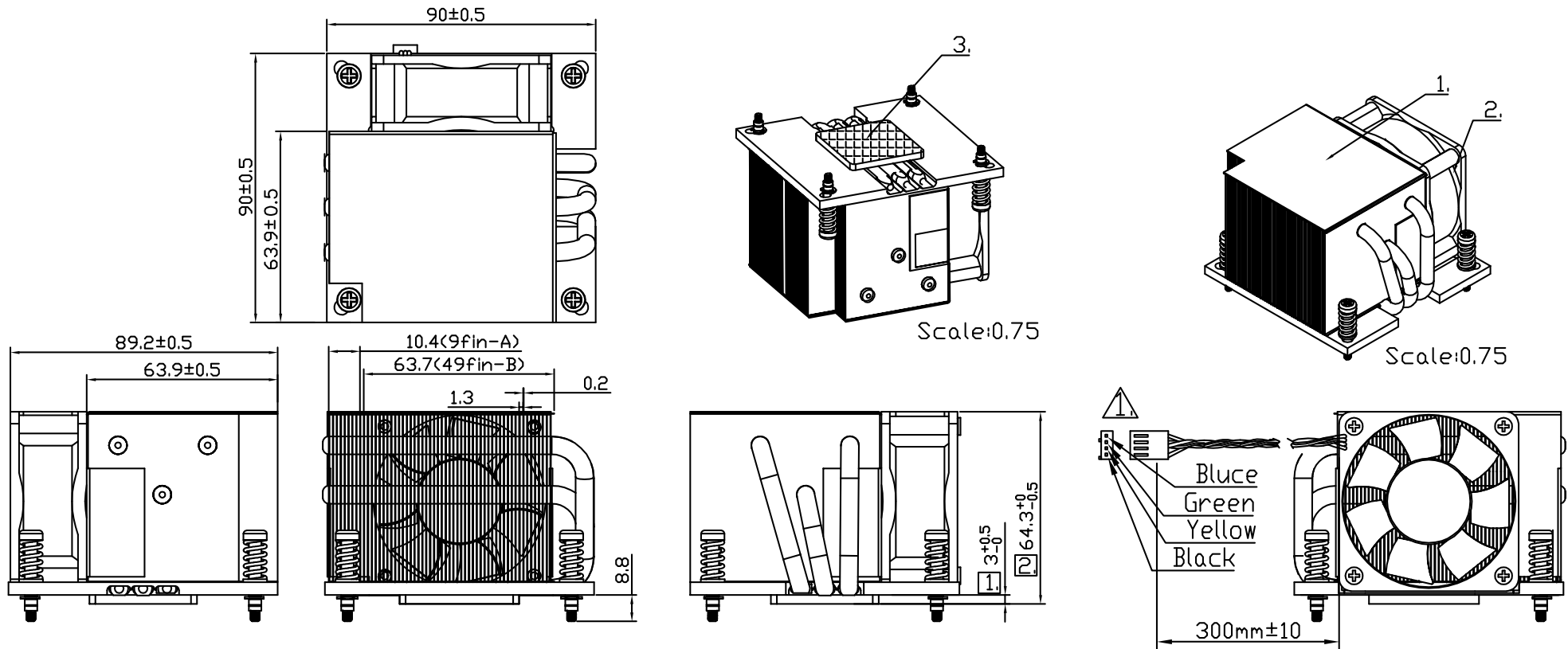

Figure 6 Cooler 125W mechanical dimension

- Cooler 80W (B9971060)

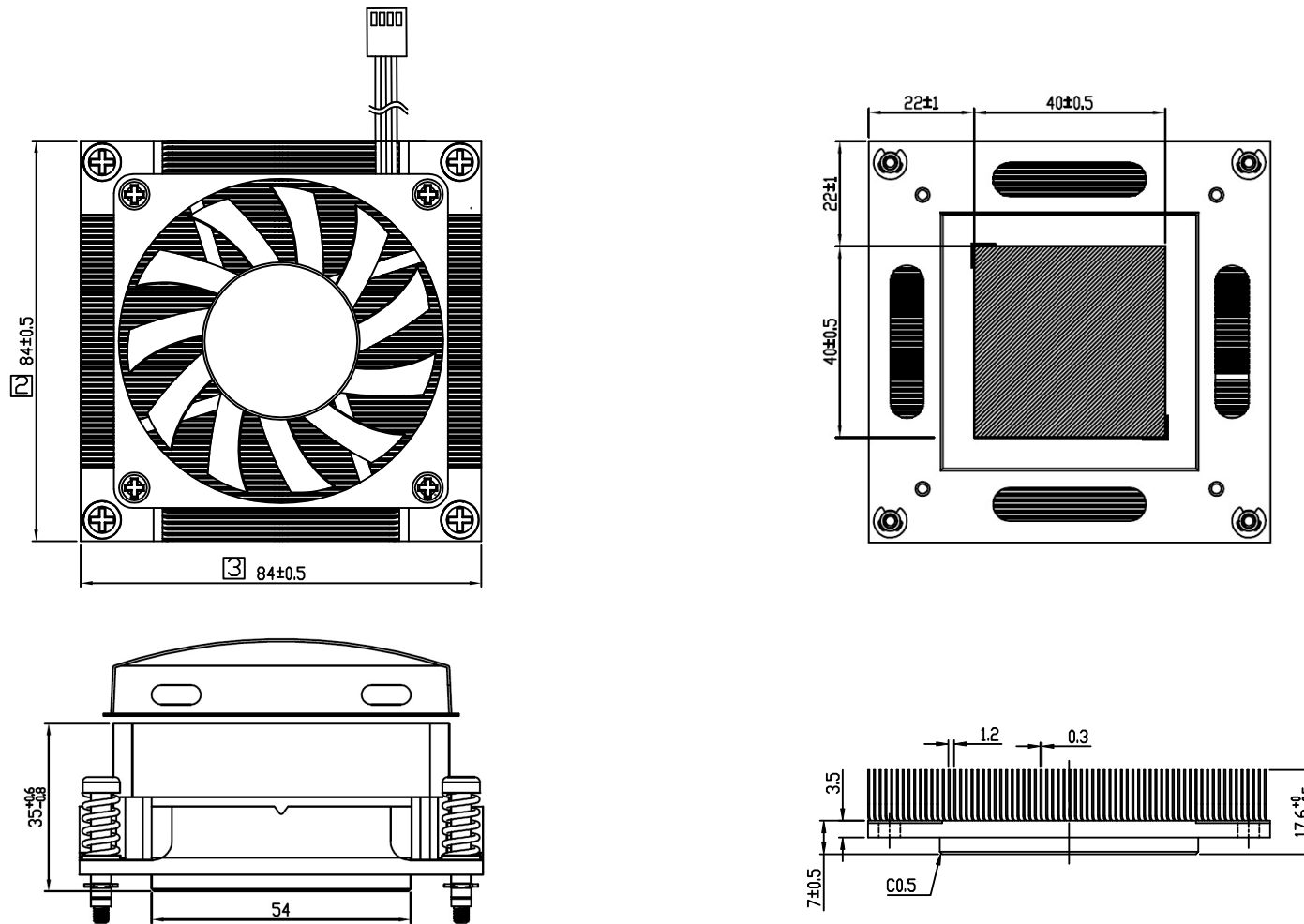

Figure 7 Cooler 80W mechanical dimension

- Cooler 35W (B8304610)

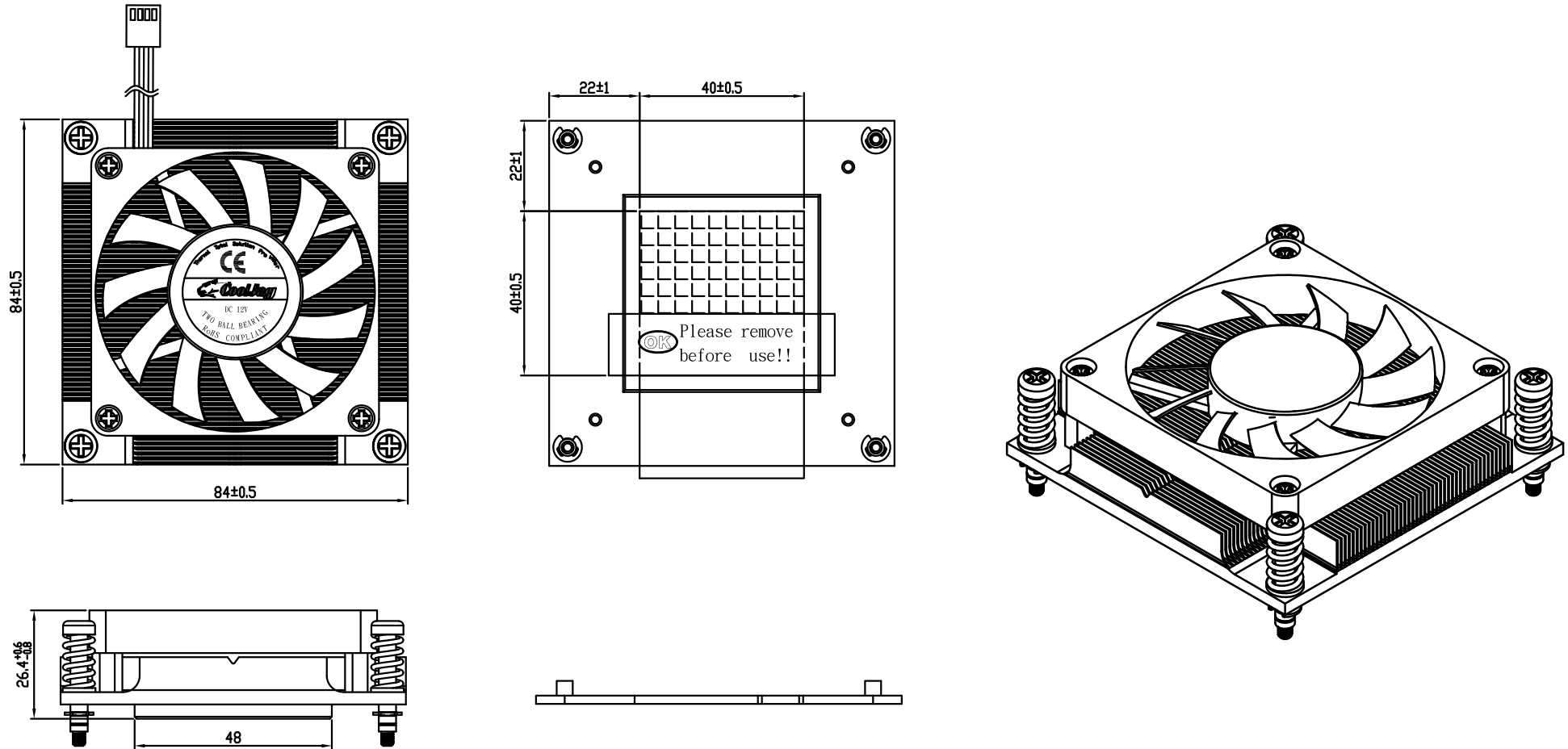

Figure 8 Cooler 35W mechanical dimension

5 Pin out Tables

Pin	Row A	Pin	Row B	Pin	Row C	Pin	Row D
A1	GND(FIXED)	B1	GND(FIXED)	C1	GND(FIXED)	D1	GND(FIXED)
A2	GBE0_MDI3-	B2	GBE0_ACT#	C2	GND	D2	GND
A3	GBE0_MDI3+	B3	LPC_FRAME#	C3	USB_SSRX0-	D3	USB_SSTX0-
A4	GBE0_LINK_1000#	B4	LPC_AD0	C4	USB_SSRX0+	D4	USB_SSTX0+
A5	GBE0_LINK_2500#	B5	LPC_AD1	C5	GND	D5	GND
A6	GBE0_MDI2-	B6	LPC_AD2	C6	USB_SSRX1-	D6	USB_SSTX1-
A7	GBE0_MDI2+	B7	LPC_AD3	C7	USB_SSRX1+	D7	USB_SSTX1+
A8	GBE0_LINK#	B8	N/C	C8	GND	D8	GND
A9	GBE0_MDI1-	B9	N/C	C9	USB_SSRX2-	D9	USB_SSTX2-
A10	GBE0_MDI1+	B10	LPC_CLK	C10	USB_SSRX2+	D10	USB_SSTX2+
A11	GND(FIXED)	B11	GND(FIXED)	C11	GND(FIXED)	D11	GND(FIXED)
A12	GBE0_MDI0-	B12	PWRBTN#	C12	USB_SSRX3-	D12	USB_SSTX3-
A13	GBE0_MDI0+	B13	SMB_CK	C13	USB_SSRX3+	D13	USB_SSTX3+
A14	N/C	B14	SMB_DAT	C14	GND	D14	GND
A15	SUS_S3#	B15	SMB_ALERT#	C15	N/C	D15	DDI1_CTRLCLK_AUX+
A16	SATA0_TX+	B16	SATA1_TX+	C16	N/C	D16	DDI1_CTRLCLK_AUX-
A17	SATA0_TX-	B17	SATA1_TX-	C17	N/C	D17	N/C
A18	SUS_S4#	B18	SUS_STAT	C18	N/C	D18	N/C
A19	SATA0_RX+	B19	SATA1_RX+	C19	PCIE_RX6+	D19	PCIE_TX6+
A20	SATA0_RX-	B20	SATA1_RX-	C20	PCIE_RX6-	D20	PCIE_TX6-
A21	GND(FIXED)	B21	GND(FIXED)	C21	GND(FIXED)	D21	GND(FIXED)

A22	SATA2_TX+	B22	SATA3_TX+	C22	PCIE_RX7+	D22	PCIE_TX7+
A23	SATA2_TX-	B23	SATA3_TX-	C23	PCIE_RX7-	D23	PCIE_TX7-
A24	SUS_S5#	B24	PWR_OK	C24	DDI1_HPD	D24	N/C
A25	SATA2_RX+	B25	SATA_RX+	C25	N/C	D25	N/C
A26	SATA2_RX-	B26	SATA_RX-	C26	N/C	D26	DDI1_PAIR0+
A27	BATLOW#	B27	WDT	C27	N/C	D27	DDI1_PAIR0-
A28	(S)ATA_ACT#	B28	N/C	C28	N/C	D28	N/C
A29	HDA_SYNC	B29	HDA_SDIN1	C29	N/C	D29	DDI1_PAIR1+
A30	HDA_RST#	B30	HDA_SDIN0	C30	N/C	D30	DDI1_PAIR1-
A31	GND(FIXED)	B31	GND(FIXED)	C31	GND(FIXED)	D31	GND(FIXED)
A32	HDA_BITCLK	B32	SPKR	C32	DDI2_CTRLCLK_AUX+	D32	DDI1_PAIR2+
A33	HDA_SDOUT	B33	I2C_CK	C33	DDI2_CTRLCLK_AUX-	D33	DDI1_PAIR2-
A34	BIOS_DIS0#	B34	I2C_DAT	C34	DDI2_DDC_AUX_SEL	D34	DDI1_DDC_AUX_SEL
A35	THRMTRIP#	B35	THRM#	C35	N/C	D35	N/C
A36	USB6-	B36	USB7-	C36	DDI3_CTRLCLK_AUX+	D36	DDI1_PAIR3+
A37	USB6+	B37	USB7+	C37	DDI3_CTRLCLK_AUX-	D37	DDI1_PAIR3-
A38	USB_6_7_OC#	B38	USB_4_5_OC#	C38	DDI3_DDC_AUX_SEL	D38	N/C
A39	USB4-	B39	USB5-	C39	DDI3_PAIR0+	D39	DDI2_PAIR0+
A40	USB4+	B40	USB5+	C40	DDI3_PAIR0-	D40	DDI2_PAIR0-
A41	GND(FIXED)	B41	GND(FIXED)	C41	GND(FIXED)	D41	GND(FIXED)
A42	USB2-	B42	USB3-	C42	DDI3_PAIR1+	D42	DDI2_PAIR1+
A43	USB2+	B43	USB3+	C43	DDI3_PAIR1-	D43	DDI2_PAIR1-
A44	USB_2_3_OC#	B44	USB_0_1_OC#	C44	DDI3_HPD	D44	DDI2_HPD
A45	USB0-	B45	USB1-	C45	N/C	D45	N/C
A46	USB0+	B46	USB1+	C46	DDI3_PAIR2+	D46	DDI2_PAIR2+
A47	VCC_RTC	B47	N/C	C47	DDI3_PAIR2-	D47	DDI2_PAIR2-

A48	N/C	B48	CPU_CFG6	C48	N/C	D48	N/C
A49	CPU_CFG5	B49	SYS_RESET#	C49	DDI3_PAIR3+	D49	DDI2_PAIR3+
A50	LPC_SERIRQ	B50	CB_RESET#	C50	DDI3_PAIR3-	D50	DDI2_PAIR3-
A51	GND(FIXED)	B51	GND(FIXED)	C51	GND(FIXED)	D51	GND(FIXED)
A52	PCIE_TX5+	B52	PCIE_RX5+	C52	PEG_RX0+	D52	PEG_TX0+
A53	PCIE_TX5-	B53	PCIE_RX5-	C53	PEG_RX0-	D53	PEG_TX0-
A54	GPI0	B54	GPO1	C54	TYPE0#	D54	N/C
A55	PCIE_TX4+	B55	PCIE_RX4+	C55	PEG_RX1+	D55	PEG_TX1+
A56	PCIE_TX4-	B56	PCIE_RX4-	C56	PEG_RX1-	D56	PEG_TX1-
A57	GND	B57	GPO2	C57	TYPE1#	D57	TYPE2#
A58	PCIE_TX3+	B58	PCIE_RX3+	C58	PEG_RX2+	D58	PEG_TX2+
A59	PCIE_TX3-	B59	PCIE_RX3-	C59	PEG_RX2-	D59	PEG_TX2-
A60	GND(FIXED)	B60	GND(FIXED)	C60	GND(FIXED)	D60	GND(FIXED)
A61	PCIE_TX2+	B61	PCIE_RX2+	C61	PEG_RX3+	D61	PEG_TX3+
A62	PCIE_TX2-	B62	PCIE_RX2-	C62	PEG_RX3-	D62	PEG_TX3-
A63	GPI1	B63	GPO3	C63	N/C	D63	N/C
A64	PCIE_TX1+	B64	PCIE_RX1+	C64	N/C	D64	N/C
A65	PCIE_TX1-	B65	PCIE_RX1-	C65	PEG_RX4+	D65	PEG_TX4+
A66	GND	B66	WAKE0#	C66	PEG_RX4-	D66	PEG_TX4-
A67	GPI2	B67	WAKE1#	C67	RAPID_SHUTDOWN	D67	GND
A68	PCIE_TX0+	B68	PCIE_RX0+	C68	PEG_RX5+	D68	PEG_TX5+
A69	PCIE_TX0-	B69	PCIE_RX0-	C69	PEG_RX5-	D69	PEG_TX5-
A70	GND(FIXED)	B70	GND(FIXED)	C70	GND(FIXED)	D70	GND(FIXED)
A71	LVDS_A0+	B71	LVDS_B0+	C71	PEG_RX6+	D71	PEG_TX6+
A72	LVDS_A0-	B72	LVDS_B0-	C72	PEG_RX6-	D72	PEG_TX6-
A73	LVDS_A1+	B73	LVDS_B1+	C73	GND	D73	GND

A74	LVDS_A1-	B74	LVDS_B1-	C74	PEG_RX7+	D74	PEG_TX7+
A75	LVDS_A2+	B75	LVDS_B2+	C75	PEG_RX7-	D75	PEG_TX7-
A76	LVDS_A2-	B76	LVDS_B2-	C76	GND	D76	GND
A77	LVDS_VDD_EN	B77	LVDS_B3+	C77	N/C	D77	N/C
A78	LVDS_A3+	B78	LVDS_B3-	C78	PEG_RX8+	D78	PEG_TX8+
A79	LVDS_A3-	B79	LVDS_BKLT_EN	C79	PEG_RX8-	D79	PEG_TX8-
A80	GND(FIXED)	B80	GND(FIXED)	C80	GND(FIXED)	D80	GND(FIXED)
A81	LVDS_A_CK+	B81	LVDS_B_CK+	C81	PEG_RX9+	D81	PEG_TX9+
A82	LVDS_A_CK-	B82	LVDS_B_CK-	C82	PEG_RX9-	D82	PEG_TX9-
A83	LVDS_I2C_CK	B83	LVDS_BKLT_CTRL	C83	N/C	D83	N/C
A84	LVDS_I2C_DAT	B84	VCC_5V_SBY	C84	GND	D84	GND
A85	GPI3	B85	VCC_5V_SBY	C85	PEG_RX10+	D85	PEG_TX10+
A86	N/C	B86	VCC_5V_SBY	C86	PEG_RX10-	D86	PEG_TX10-
A87	N/C	B87	VCC_5V_SBY	C87	GND	D87	GND
A88	PCIE_CLK_REF+	B88	BIOS_DIS1#	C88	PEG_RX11+	D88	PEG_TX11+
A89	PCIE_CLK_REF-	B89	VGA_RED	C89	PEG_RX11-	D89	PEG_TX11-
A90	GND(FIXED)	B90	GND(FIXED)	C90	GND(FIXED)	D90	GND(FIXED)
A91	SPI_POWER	B91	VGA_GRN	C91	PEG_RX12+	D91	PEG_TX12+
A92	SPI_MISO	B92	VGA_BLU	C92	PEG_RX12-	D92	PEG_TX12-
A93	GPO0	B93	VGA_HSYNC	C93	GND	D93	GND
A94	SPI_CLK	B94	VGA_VSYNC	C94	PEG_RX13+	D94	PEG_TX13+
A95	SPI_MOSI	B95	VGA_I2C_CK	C95	PEG_RX13-	D95	PEG_TX13-
A96	N/C	B96	VGA_I2C_DAT	C96	GND	D96	GND
A97	TYPE10#	B97	SPI_CS#	C97	N/C	D97	N/C
A98	SER0_TX	B98	N/C	C98	PEG_RX14+	D98	PEG_TX14+
A99	SER0_RX	B99	N/C	C99	PEG_RX14-	D99	PEG_TX14-

A100	GND(FIXED)	B100	GND(FIXED)	C100	GND(FIXED)	D100	GND(FIXED)
A101	SER1_TX	B101	FAN_PWNOUT	C101	PEG_RX15+	D101	PEG_TX15+
A102	SER1_RX	B102	FAN_TACHIN	C102	PEG_RX15-	D102	PEG_TX15-
A103	LID#	B103	SLEEP#	C103	GND	D103	GND
A104	VCC_12V	B104	VCC_12V	C104	VCC_12V	D104	VCC_12V
A105	VCC_12V	B105	VCC_12V	C105	VCC_12V	D105	VCC_12V
A106	VCC_12V	B106	VCC_12V	C106	VCC_12V	D106	VCC_12V
A107	VCC_12V	B107	VCC_12V	C107	VCC_12V	D107	VCC_12V
A108	VCC_12V	B108	VCC_12V	C108	VCC_12V	D108	VCC_12V
A109	VCC_12V	B109	VCC_12V	C109	VCC_12V	D109	VCC_12V
A110	GND(FIXED)	B110	GND(FIXED)	C110	GND(FIXED)	D110	GND(FIXED)

Table 11 Pin out description

6 System Resources

LPC

Device	I/O Address	Note
Embedded Controller	0x6E / 0x6F	EC Address
	0x62 / 0x66	EC ACPI CMD Port
	0x200 / 0x201	EC BRAM Port for I2C function
	0x300~0x3FF	EC LPC IO Space
	0x3F8~0x3FF	EC UART1
	0x3E8~0x3EF	EC UART2
Carrier SIO	N/A	

SMBUS

SMBUS Address	Information
0x44	SMBus ARP
0x6C	PCIe Clock Buffer
0x10 / 0x12 / 0x16 / 0x48	Reserved

Table 12 System Resources

7 BIOS Setup Items

7.1 Introduction

The following section describes the BIOS setup program. The BIOS setup program can be used to view and change the BIOS settings for the module. Only experienced users should change the default BIOS settings.

7.2 BIOS Setup

Power on the computer and the system will start POST (Power on Self Test) process. When the message below appears on the screen, press <Delete> or <ESC> key will enter BIOS setup screen.

Press <ESC > or <Delete> to enter SETUP

If the message disappears before responding and still wish to enter Setup, please restart the system by turning it OFF and On or pressing the RESET button. It can be also restarted by pressing <Ctrl>, <Alt>, and <Delete> keys on keyboard simultaneously.

Press <F1> to Run General Help or Resume

The BIOS setup program provides a General Help screen. The menu can be easily called up from any menu by pressing <F1>. The Help screen lists all the possible keys to use and the selections for the highlighted item. Press <Esc> to exit the Help Screen.

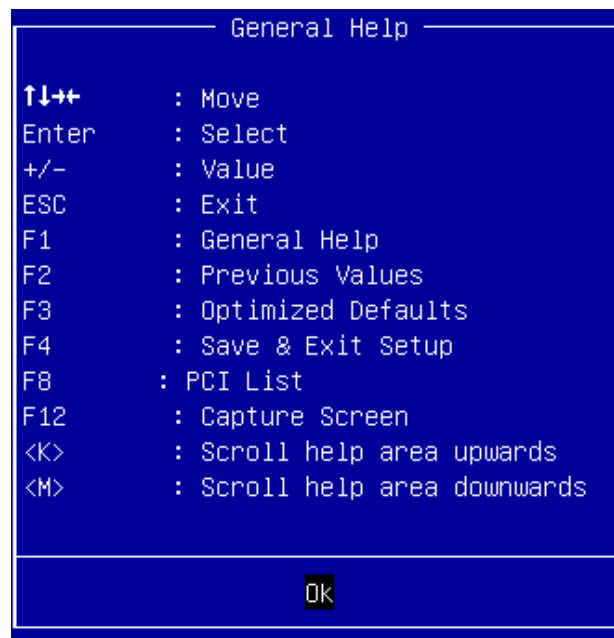

7.2.1 Main

Use this menu for basic system configurations, such as time, date etc.

```
Aptio Setup - AMI
Main Configuration Security Boot Save & Exit

Project Name                PCOM-B880VG2
BIOS Version & Build Date   0.0.10 (09/20/2022 09:22:16)
EC Version & Build Date     0.4 (07/22/2022)
Access Level                Administrator

Processor Information
Name                        CometLake DT
Type                        Intel(R) Core(TM) i9-10900TE CPU @ 1.80GHz

Total Memory                8192 MB

PCH Information
PCH SKU                     Q470

▶ Detailed System Information

System Date                 [Fri 01/01/2021]
System Time                 [02:04:22]
```

7.2.2 Configuration

Use this menu to set up the items of special enhanced features

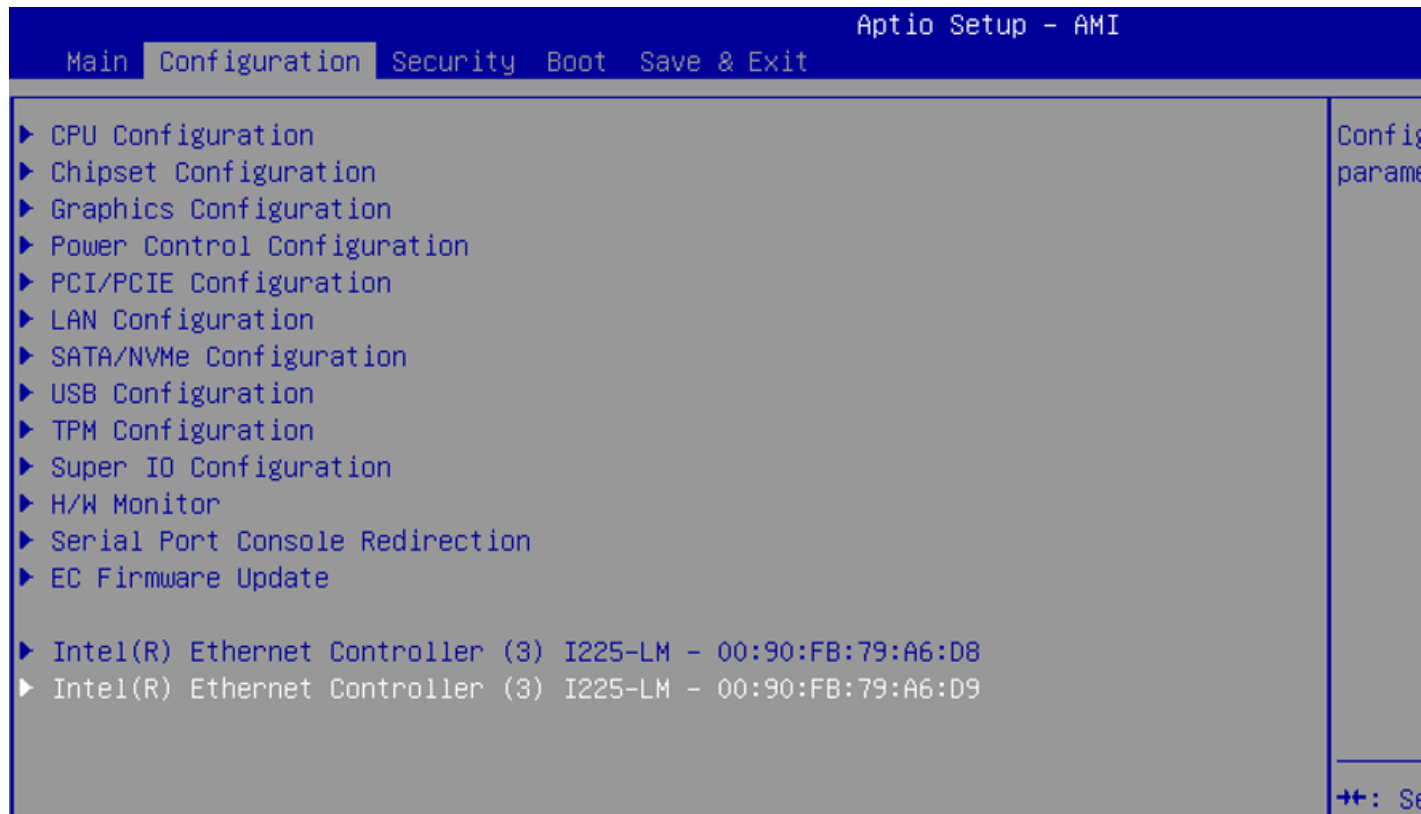

- **CPU Configuration**
CPU Configuration Parameters

Aptio Setup - AMI

Configuration

CPU Configuration		Number of cores to enable in each processor package.
Type	Intel(R) Core(TM) i9-10900TE CPU @ 1...	++: Select Screen ↑↓: Select Item Enter: Select +/-: Change Opt. F1: General Help F2: Previous Values F3: Optimized Defaults F4: Save & Exit F8: PCI List F12: Capture Screen ESC: Exit
ID	0xA0654	
Speed	1800 MHz	
L1 Data Cache	32 KB x 10	
L1 Instruction Cache	32 KB x 10	
L2 Cache	256 KB x 10	
L3 Cache	20 MB	
L4 Cache	N/A	
VMX	Supported	
SMX/TXT	Supported	
Active Processor Cores	[All]	
Hyper-Threading	[Enabled]	
Boot performance mode	[Max Non-Turbo Performance]	
Intel (VMX) Virtualization Technology	[Enabled]	
Intel(R) SpeedStep(tm)	[Enabled]	
Intel(R) Speed Shift Technology	[Enabled]	
Turbo Mode	[Enabled]	
C states	[Enabled]	
Enhanced C-states	[Enabled]	
C-State Auto Demotion	[C1 and C3]	
C-State Un-demotion	[C1 and C3]	
Package C-State Demotion	[Disabled]	
Package C-State Un-demotion	[Disabled]	
CState Pre-Wake	[Enabled]	
IO MWAIT Redirection	[Disabled]	
Package C State Limit	[Auto]	

Feature	Description	Options
Active Processor Cores	Number of cores to enable in each processor package.	★All, 1, 2, 3, 4, 5, 6, 7, 8, 9
Hyper-Threading	Enabled or Disabled Hyper-Threading Technology.	★Enabled, Disabled
Boot performance mode	Select the performance state that the BIOS will set starting from reset vector	Max Battery, ★Max Non-Turbo Performance Turbo Performance
Intel (VMX) Virtualization Technology	When enabled, a VMM can utilize the additional hardware capabilities provided by Vander pool Technology.	★Enabled, Disabled
Intel® Speed Step™	Allows more than two frequency ranges to be supported.	★Enabled, Disabled
Intel® Speed Shift Technology	Enable/Disable Intel® Speed Shift Technology support. Enabling will expose the CPPC v2 interface to allow for hardware controlled P-states	★Enabled, Disabled
Turbo Mode	Enable/Disable processor Turbo Mode (requires Intel Speed Step or Intel Speed Shift to be available and enabled)	★Enabled, Disabled
C states	Enable/disable CPU Power Management. Allows CPU to go to C states It's not 100% utilized	★Enabled, Disabled
Enhanced C-states	Enable/Disable C1E. When enabled, CPU will switch to minimum speed when all cores enter C-State.	★Enabled, Disabled
C-State Auto Demotion	Configure C-State Auto Demotion	Disable, C1 ,C3 , ★C1 and C3
C-State Un-demotion	Configure C-State Un-demotion	Disable, C1 ,C3 , ★C1 and C3
Package C State Demotion	Package C-State Demotion	★Disabled, Enabled
Package C State Un-demotion	Package C-State Un-demotion	★Disabled, Enabled
CState Pre-Wake	Disable – Sets bit 30 of POWER_CTL MSR(0x1FC) to 1 to disable the Cstate Pre-Wake	Disabled, ★Enabled
IO MWAIT Redirection	When set, will map IO_read instructions sent to IO registers PMG_IO_BASE_ADDRBASE+offset to MWAIT(offset)	★Disabled, Enabled
Package C State Limit	Maximum Package C State Limit Setting. Cpu Default: Leaves to Factory default value. Auto: Initializes to deepest available Package C States Limit	★Auto,C0,C1,C2,C3,C6,C7 ,C7S,C8,C9,C10,Cpu Default,

- **Chipset Configuration**
Configuration Chipset feature

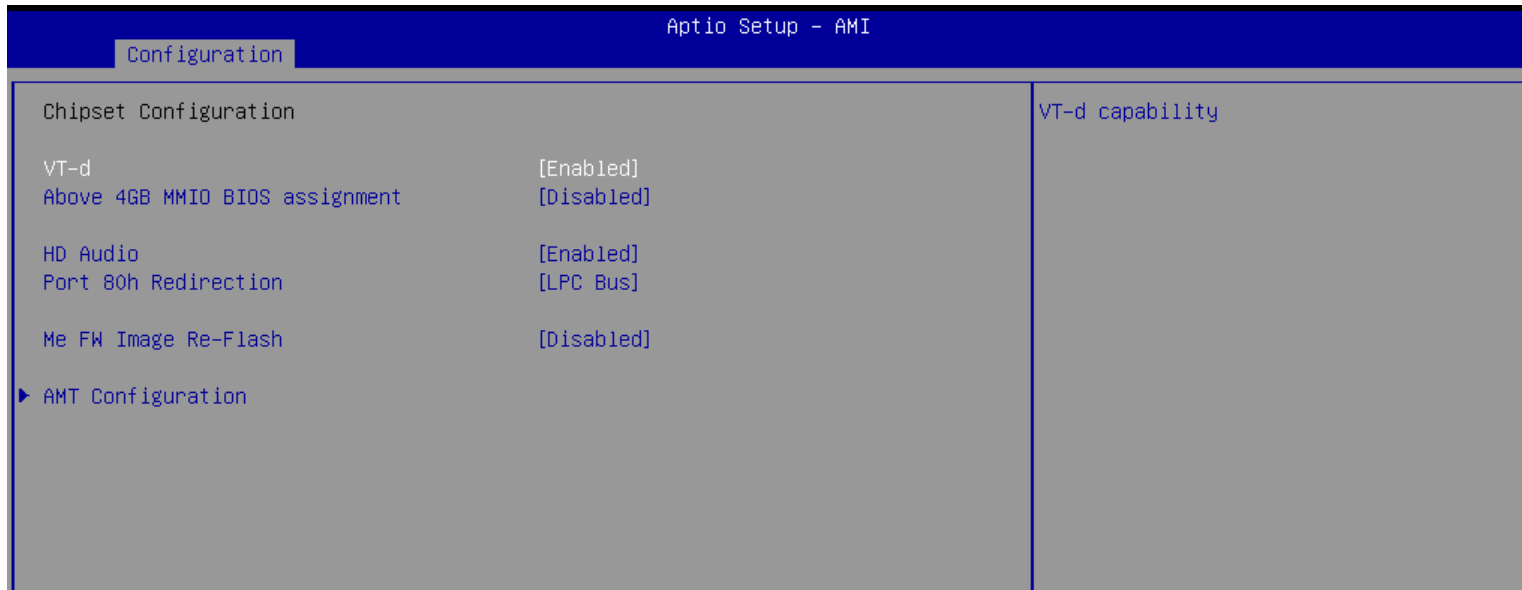

Feature	Description	Options
VT-d	VT-d Capability	★Enabled ,Disabled
Above 4GB MMIO BIOS assignment	Enable/Disable above 4GB MemoryMappedIO BIOS assignment This is enabled automatically when Aperture Size is set to 2048MB	★Disabled, Enabled
HD Audio	Control Detection of the HD-Audio device. Disabled= HAD will be unconditionally disabled Enabled= HAD will be unconditionally enabled.	★Enabled ,Disabled
Port 80h Redirection	Control where the Port 80h cycles are sent	★LPC Bus, PCIE Bus
Me FW Image Re-Flash	Enable/Disable Me FW Image Re-Flash function	★Disabled, Enabled

- **AMT Configuration**
Configure Intel® Active Management Technology Parameters

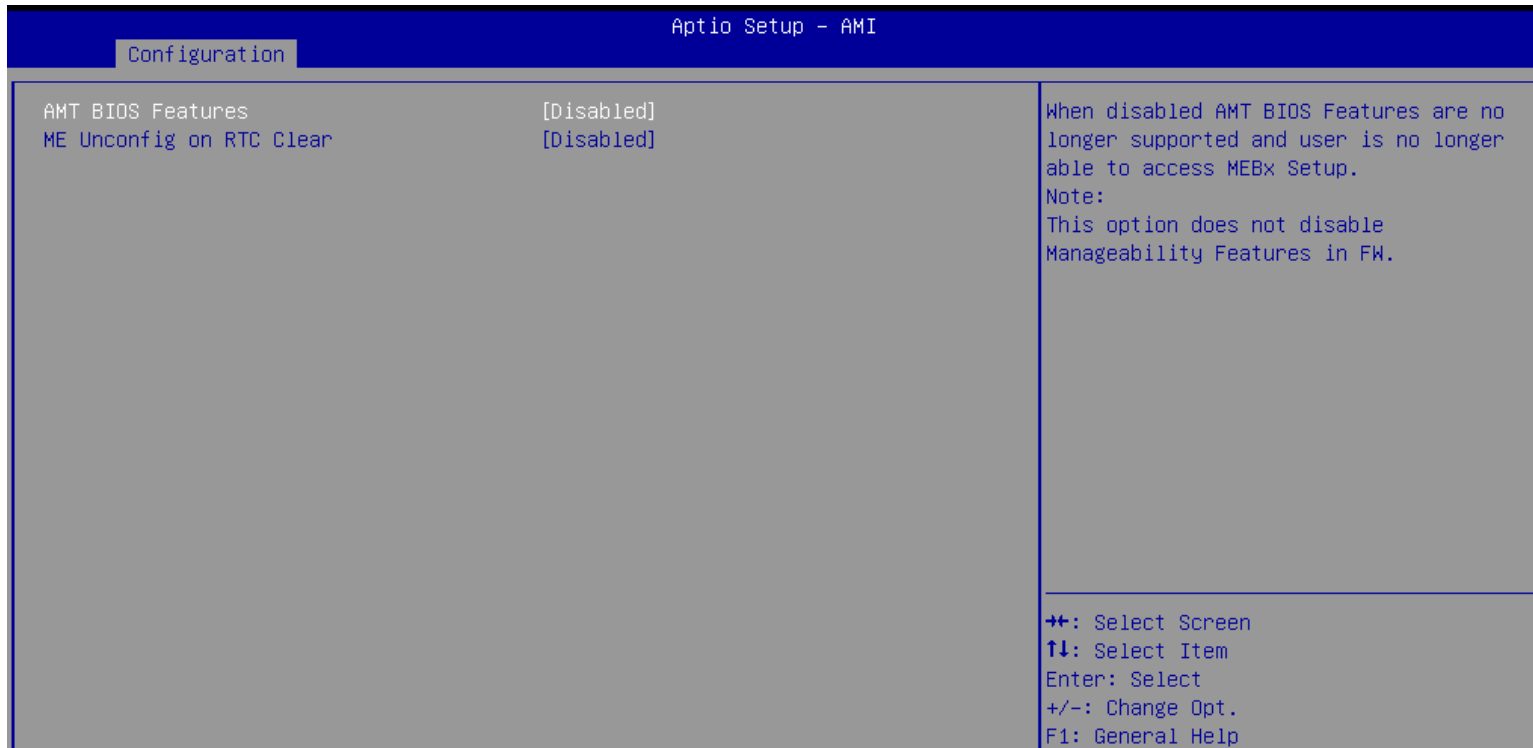

Feature	Description	Options
AMT BIOS Features	When disable AMT BIOS Features are no longer supported and user is no longer able to access MEBx Setup. Note: This option does not disable Manageability Features in FW	★Disabled, Enabled
ME Unconfig on RTC Clear	When Disable ME will not be unconfigured on RTC Clear	★Disabled, Enabled

- **Graphics Configuration**
Configuration Graphics Settings

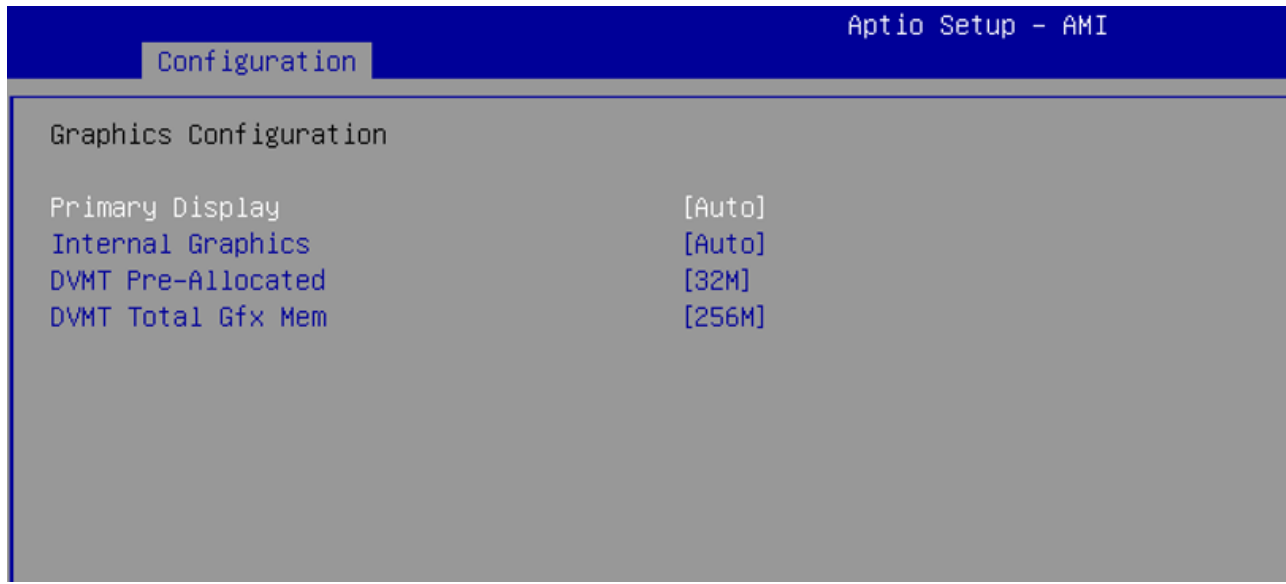

Feature	Description	Options
Primary Display	Select which of IGFX/PEG/PCI Graphics device should be Primary Display Or select HG for Hybrid Gfx.	★Auto, IGFX, PEG Slot, PCH PCI
Internal Graphics	Keep IGFX enable based on the setup options.	★Auto, Disable, Enable
DVMT Pre-Allocated	Select DVMT 5.0 Pre-Allocated (Fixed) Graphics Memory size used by the Internal Graphics Device.	★32M, 32M,64M,8M,12M,16M,20M,24M,28M, 32M/F7,36M,40M,44M,48M,52M,56M,
DVMT Total Gfx Mem	Select DVMT5.0 Total Graphic Memory size used by the Internal Graphics Device	★256M, 128M, MAX

- **Power Control Configuration**
System Power Control Configuration Parameters

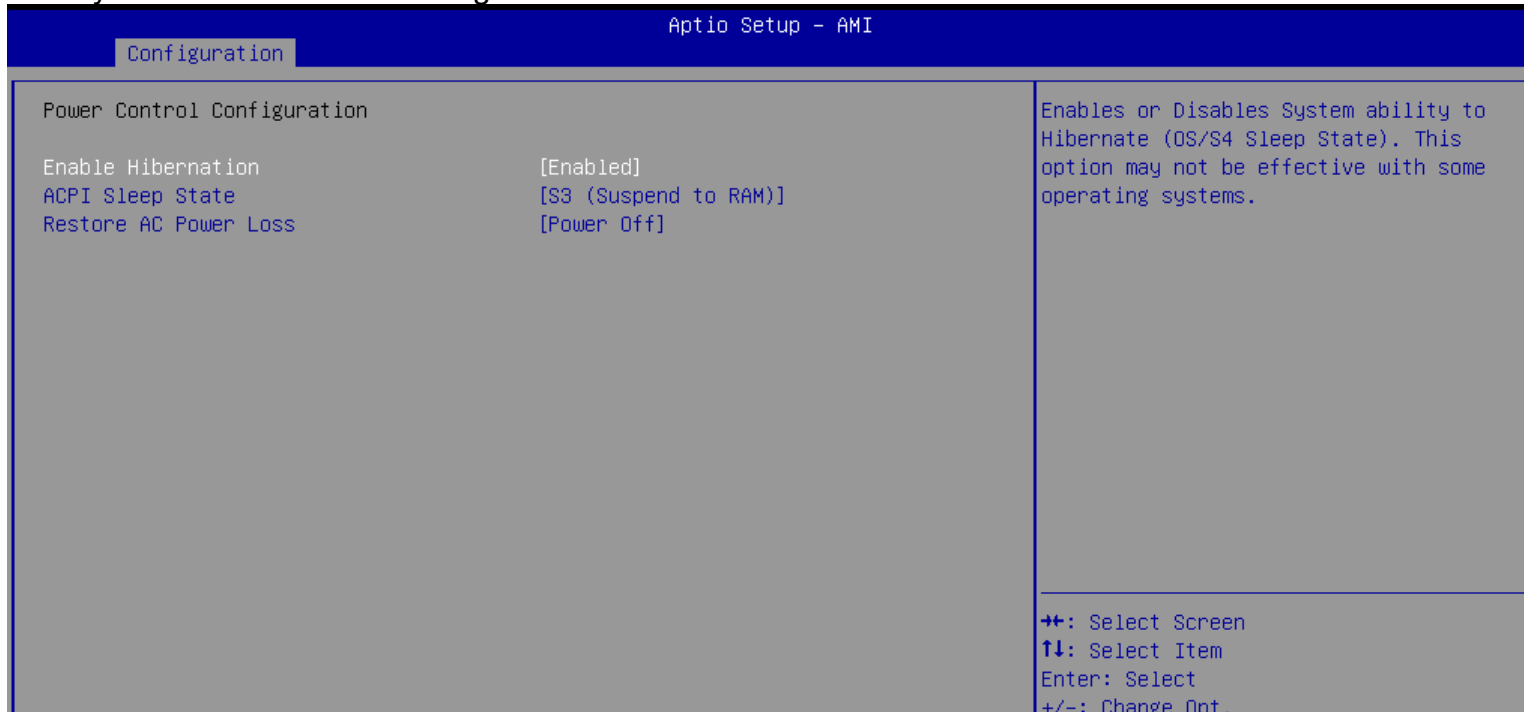

Feature	Description	Options
Enable Hibernation	Enables or Disables System ability to Hibernate (OS/S4 Sleep State). This option may not be effective with some operating system	★Enabled ,Disabled
ACPI Sleep State	Select the highest ACPI sleep state the system will enter when the SUSPEND button is pressed.	★S3 (Suspend to RAM), Suspend Disabled
Restore AC Power Loss	Specify what state to go to when power is re-applied after a power failure(G3 state)	★Power Off, Power ON, Last State

- **PCI/PCIE Configuration**
PCI / PCI Express Settings

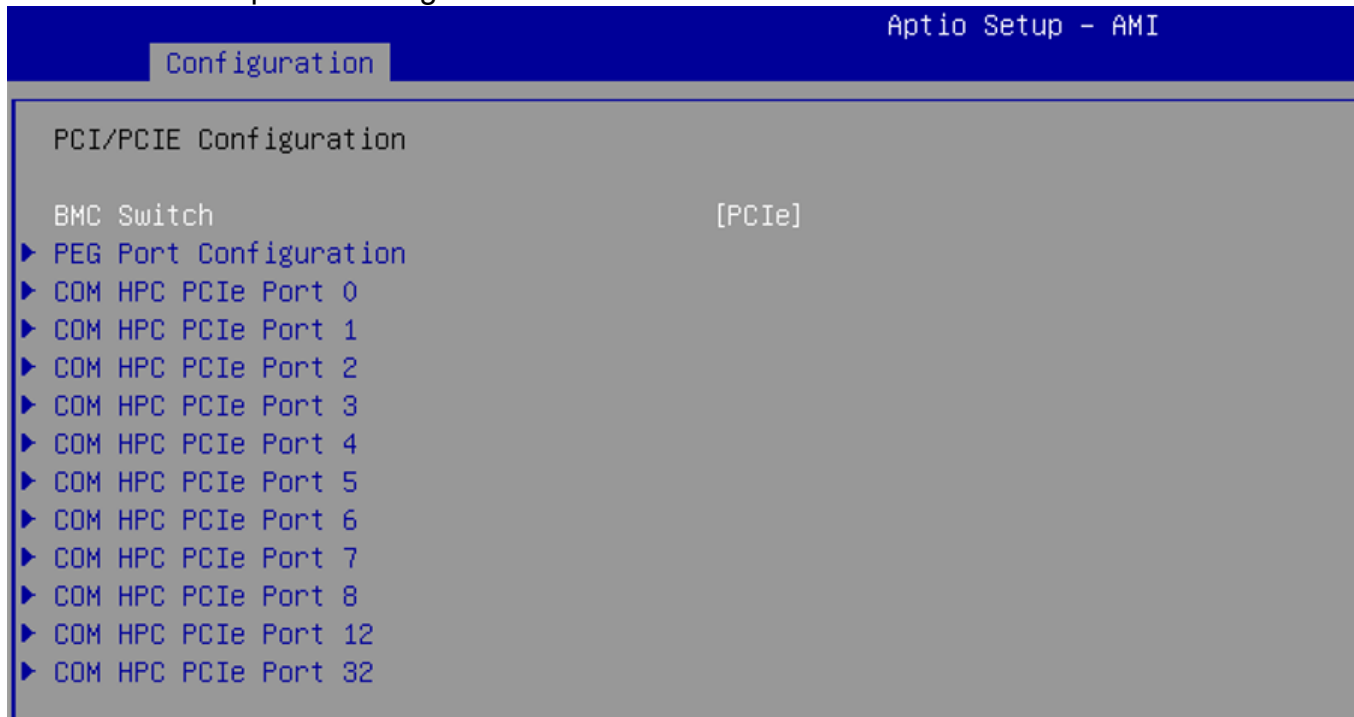

Feature	Description	Options
BMC Switch	Set switch to PCIe or BMC PCIe	★PCIe, BMC PCIe
PEG Port Configuration	PEG Port Options	
COM HPC PCIe Port	PCI Express Root Port Settings.	

- **PEG Port Configuration**

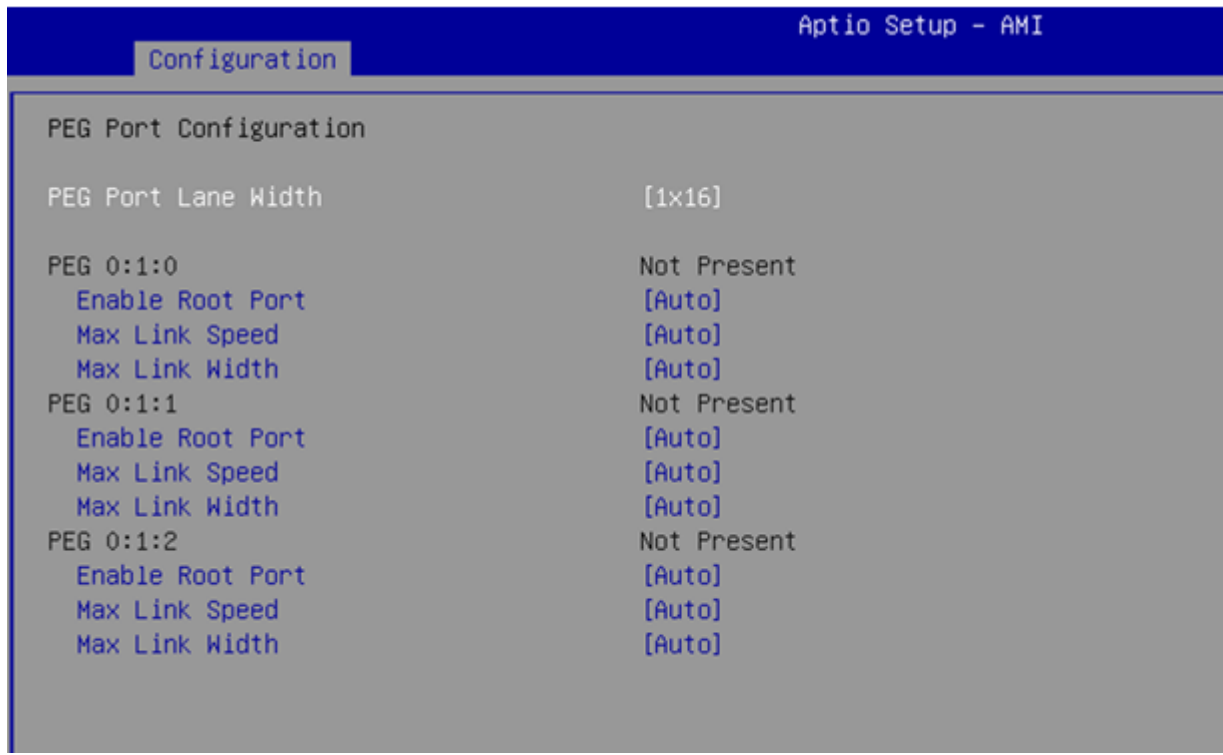

Feature	Description	Options
PEG Port Lane Width	Set PEG port lane width	★1x16, 2x8, 1x8_2x4
Enable Root Port	Enable or Disable the Root Port	Disabled, Enabled, ★Auto
Max Link Speed	Configure PEG port Max Speed	★Auto, Gen1, Gen2, Gen3
Max Link Width	Force PEG link to retrain to x1/2/4/8	★Auto, Force X1, Force X2, Force X4, Force X8

- **COM HPC PCIe Port**
PCI Express Root Port Settings

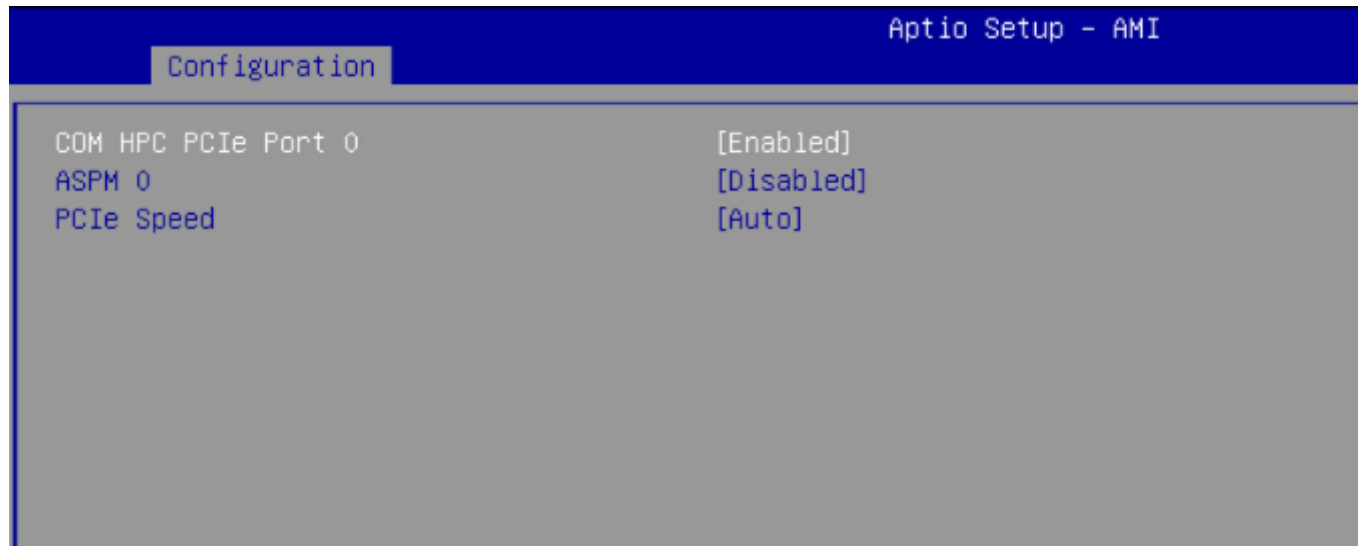

Feature	Description	Options
COM HPC PCIe Port	Control the PCI Express Root Port.	★Enabled, Disabled
ASPM	Set the ASPM Level: Force L0s – Force all links to L0s State AUTO - BIOS auto configure DISABLE – Disables ASPM	★Disabled, L0s, L1, L0sL1, Auto
PCIe Speed	Configure PCIe Speed	★Auto, Gen1, Gen2, Gen3

- **LAN Configuration**
Configuration On Board LAN Device

```
Aptio Setup - AMI
Configuration
LAN Configuration

Intel Ethernet Controller I225LM
LAN MAC Address          00-90-FB-79-A6-D8
Intel LAN I225 Controller#0 [Enabled]

Intel Ethernet Controller I225LM
LAN MAC Address          00-90-FB-79-A6-D9
Intel LAN I225 Controller#1 [Enabled]

PCIE_WAKE(Wake On Lan)   [Enabled]
Launch UEFI PXE ROM      [Enabled]
  IPv4 PXE Support        [Enabled]
  IPv4 HTTP Support       [Enabled]
  IPv6 PXE Support        [Enabled]
  IPv6 HTTP Support       [Enabled]
PXE boot wait time       0
Media detect count       1
```

Feature	Description	Options
Intel LAN I255 Controller	Control the PCI Express Root Port.	★Enabled , Disabled
PCIE_WAKE(Wake On Lan)	Control PCIE Wake# pin for Wake On Lan function.	★Enabled , Disabled
Launch UEFI PXE ROM	Enable/Disable UEFI Network Stack.	★Disabled, Enabled
Launch UEFI PXE ROM [Enable]		
Ipv4 PXE Support	Enable/Disable Ipv4 PXE boot support. If disabled, IPv4 PXE boot support will not be available.	★Enabled , Disabled
Ipv4 HTTP Support	Enable/Disable Ipv4 HTTP boot support. If disable, IPv4 HTTP boot support will not be available.	★Enabled , Disabled
Ipv6 PXE Support	Enable/Disable Ipv6 PXE boot support. If disable, IPv6 PXE boot support will not be available.	★Enabled , Disabled
Ipv6 HTTP Support	Enable/Disable Ipv6 HTTP boot support. If disable, IPv6 HTTP boot support will not be available.	★Enabled , Disabled
PXE boot wait time	Wait time in seconds to press ESC key to abort the PXE boot. Use either +/- or numeric keys to set the value.	★0
Media detect count	Number of times the presence of media will be checked. Use either +/- or numeric keys to set the value.	★1

- **SATA/NVMe Configuration**
SATA/NVMe Device Options Settings

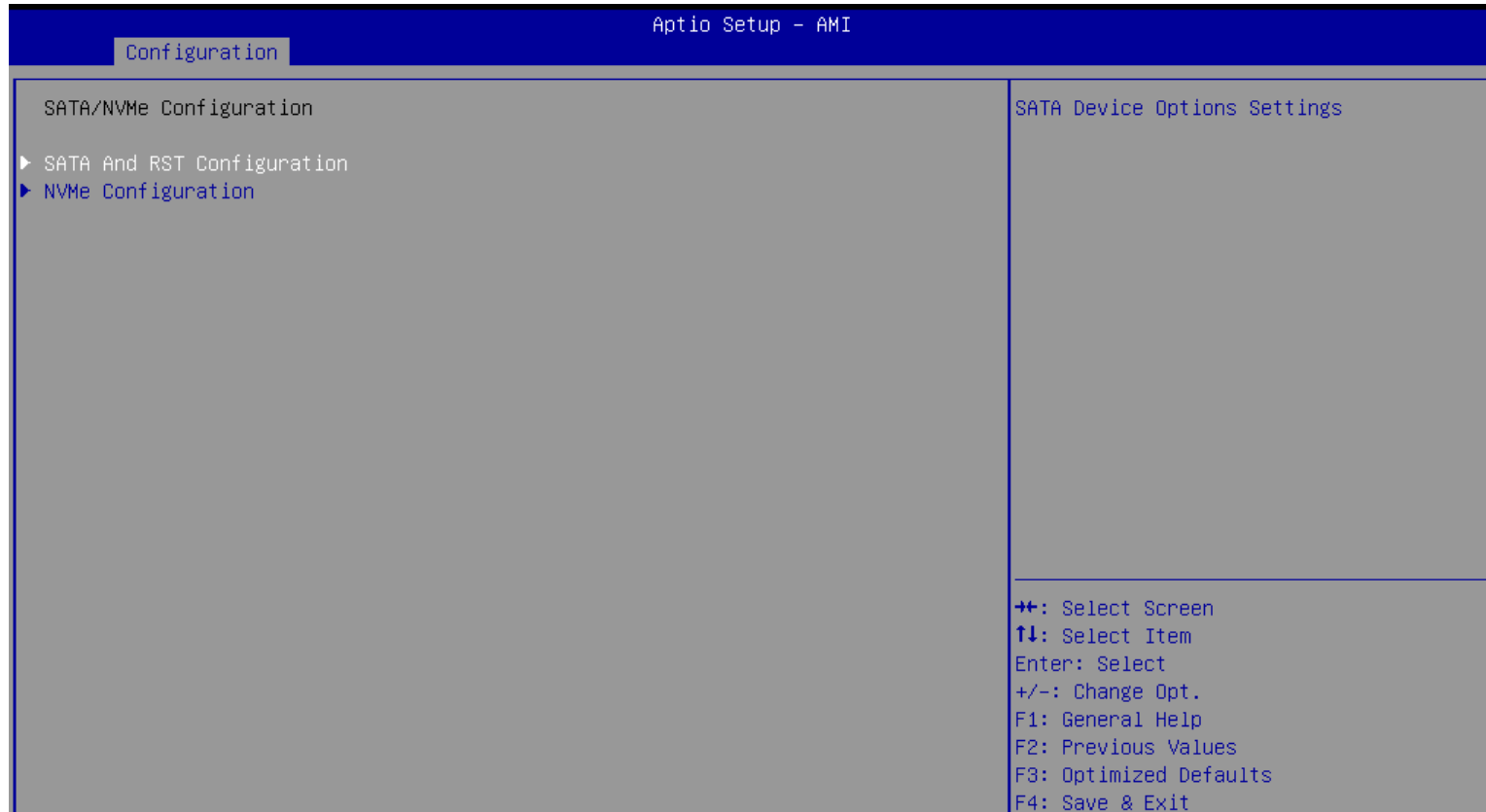

Feature	Description	Options
SATA And RST Configuration	SATA Device Options Settings	
NVMe Configuration	NVMe Device Options Settings	

- **SATA And RST Configuration**

SATA And RST Configuration

```
Aptio Setup - AMI
Configuration
SATA And RST Configuration

SATA Controller(s)           [Enabled]
SATA Mode Selection          [AHCI]
SATA Controller Speed        [Default]

COM HPC SATA Port 0          Empty
  Software Preserve          Unknown
  Port 0                     [Enabled]
  Hot Plug                    [Disabled]
  Configured as eSATA        Hot Plug supported
  SATA Device Type           [Hard Disk Drive]
COM HPC SATA Port 1          Empty
  Software Preserve          Unknown
  Port 1                     [Enabled]
  Hot Plug                    [Disabled]
  Configured as eSATA        Hot Plug supported
  SATA Device Type           [Hard Disk Drive]
```

Feature	Description	Options
SATA Controller(s)	Enable/Disable the SATA Device.	★Enabled , Disabled
SATA Mode Selection	Determines how SATA controller(s) operate	★AHCI, Intel RST With Intel Optane System Acceleration
SATA Controller Speed	Indicates the maximum speed the SATA controller can support	
COM HPC SATA Port 0,1		
Port 0,1	Enable or Disable SATA Port	★Enabled ,Disabled
Hot Plug	Designates this port as Hot Pluggable	★Disabled, Enabled
SATA Device Type	Identify the SATA port is connected to Solid State Drive or Hard Disk Drive	★Hard Disk Drive, Solid State Drive

- **NVMe Configuration**
NVMe Device Options Settings.

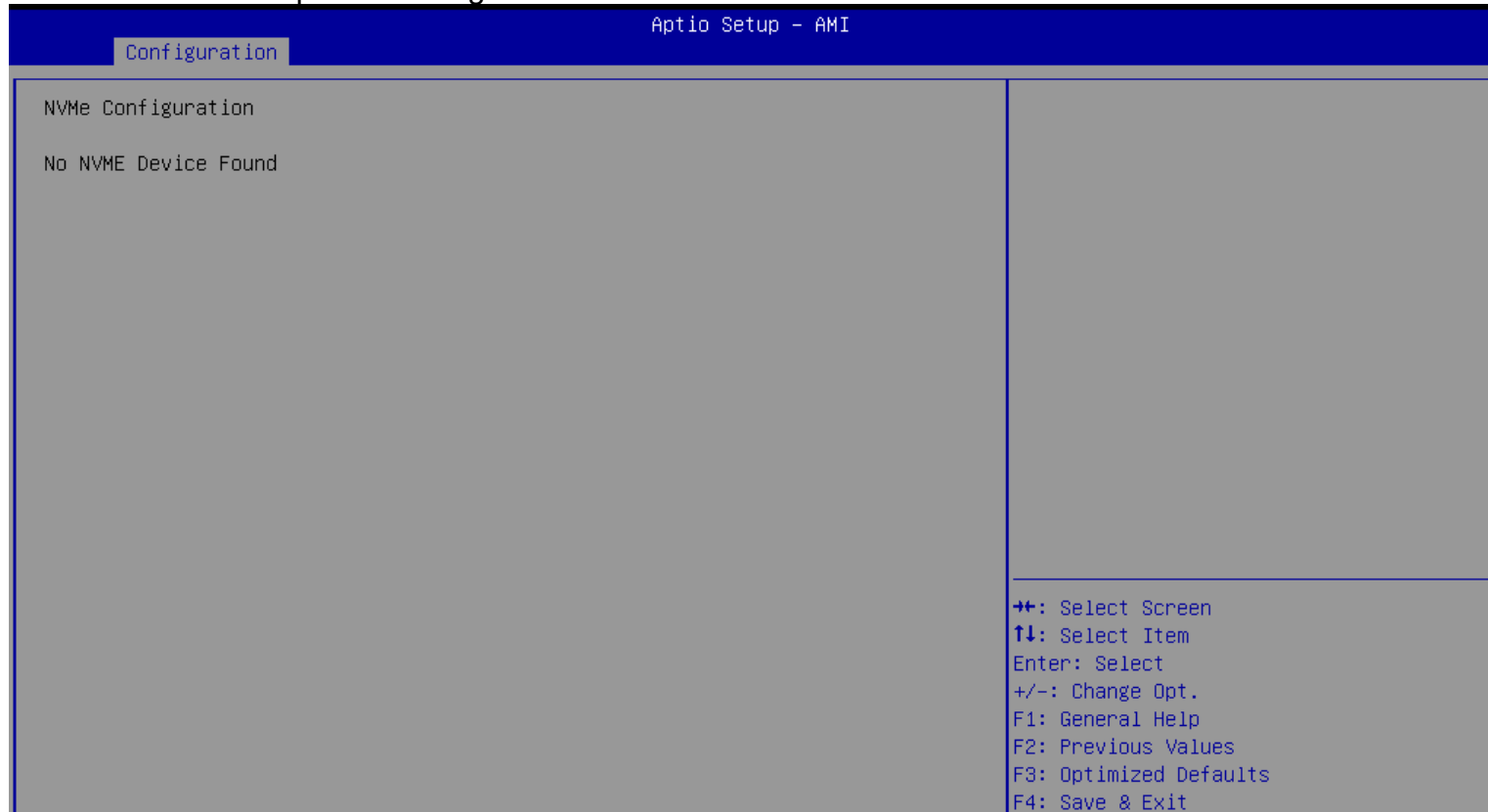

- **USB Configuration**
USB Configuration Parameters

```
Aptio Setup - AMI
Configuration
USB Configuration
USB Controllers:
  1 XHCI
USB Devices:
  1 Keyboard

COM HPC USB 3.0 Port 0      [Enabled]
COM HPC USB 3.0 Port 1      [Enabled]
COM HPC USB 3.0 Port 2      [Enabled]
COM HPC USB 3.0 Port 3      [Enabled]
COM HPC USB 2.0 Port 0      [Enabled]
COM HPC USB 2.0 Port 1      [Enabled]
COM HPC USB 2.0 Port 2      [Enabled]
COM HPC USB 2.0 Port 3      [Enabled]
COM HPC USB 2.0 Port 4      [Enabled]
COM HPC USB 2.0 Port 5      [Enabled]
COM HPC USB 2.0 Port 6      [Enabled]
COM HPC USB 2.0 Port 7      [Enabled]

Legacy USB Support          [Enabled]
XHCI Hand-off               [Enabled]
USB Mass Storage Driver Support [Enabled]
```

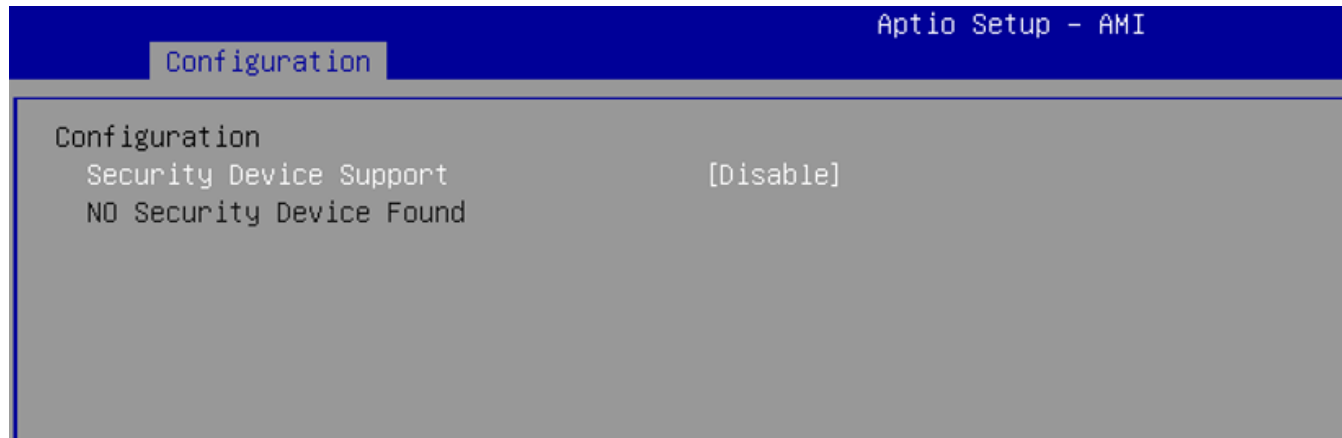

Feature	Description	Options
COMe USB 3.0 Port #0~3	Enable/Disable this USB Physical Connector (physical port). Once disable, any USB devices plug into the connector will not be detected by BIOS or OS.	★Enabled , Disabled
COMe USB 2.0 Port #0~7	Enable/Disable this USB Physical Connector (physical port). Once disable, any USB devices plug into the connector will not be detected by BIOS or OS.	★Enabled , Disabled
Legacy USB Support	Enables Legacy USB support. AUTO option disables legacy support if no USB devices are connected. DISABLE option will keep USB devices available only for EFI application	★Enabled , Disabled, Auto
XHCI Hand-off	This is a workaround for Oses without XHCI hand-off support. The XHCI ownership change should be claimed by XHCI driver	★Enabled , Disabled
USB Mass Storage Driver Support	Enable/Disable USB Mass Storage Driver Support	★Enabled , Disabled

- **TPM Configuration**
Trust Computing Settings

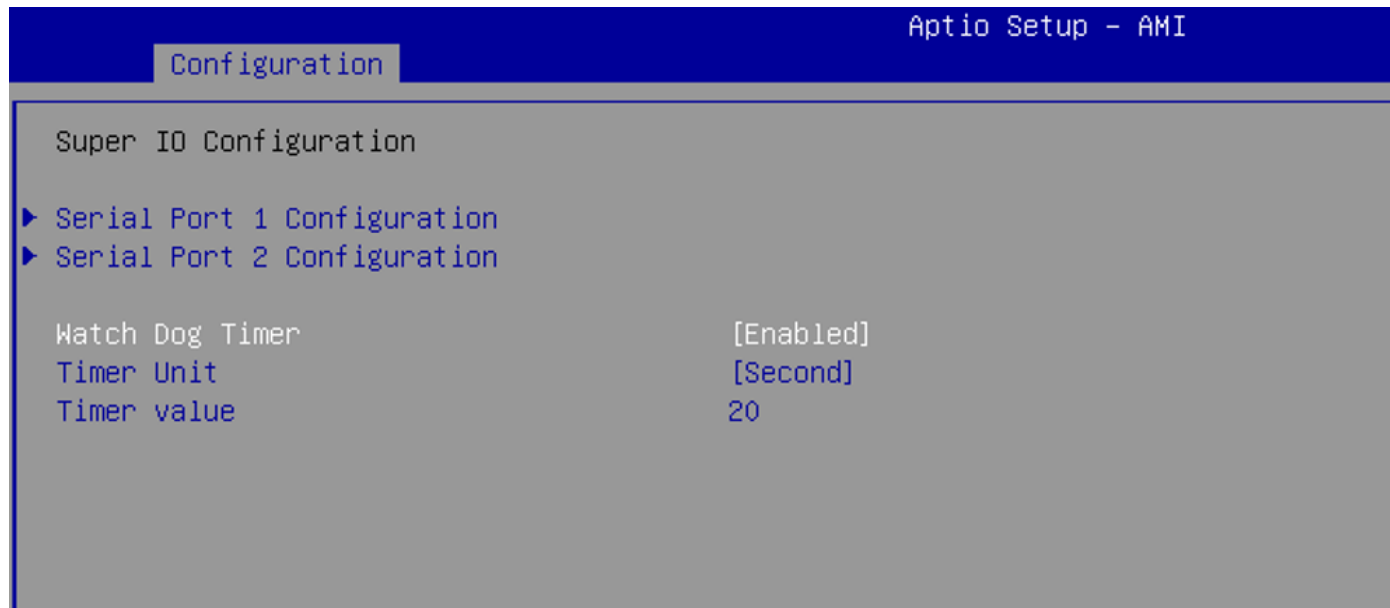

Feature	Description	Options
Security Device Support	Enables or Disables BIOS support for security device. O.S. will not show Security Device. TCG EFI protocol and INT1A Interface will not be available.	★Disabled, Enabled

- **Super IO Configuration**
System Super IO Chip Parameters



Feature	Description	Options
Serial Port 1, 2 Configuration	Set Parameters of Serial Port 1(COMA) and Port 2(COMB)	
Watch Dog Timer	Enable/Disable Watch Dog Timer	★Disabled, Enabled
Watch Dog Timer[Enable]		
Timer Unit	Select Timer count unit of WDT	★Second, Minute
Timer value	Set WDT Timer value seconds/minutes	★20

- **Serial Port 1/2 Configuration**
Set Parameters of Serial Port 1/2

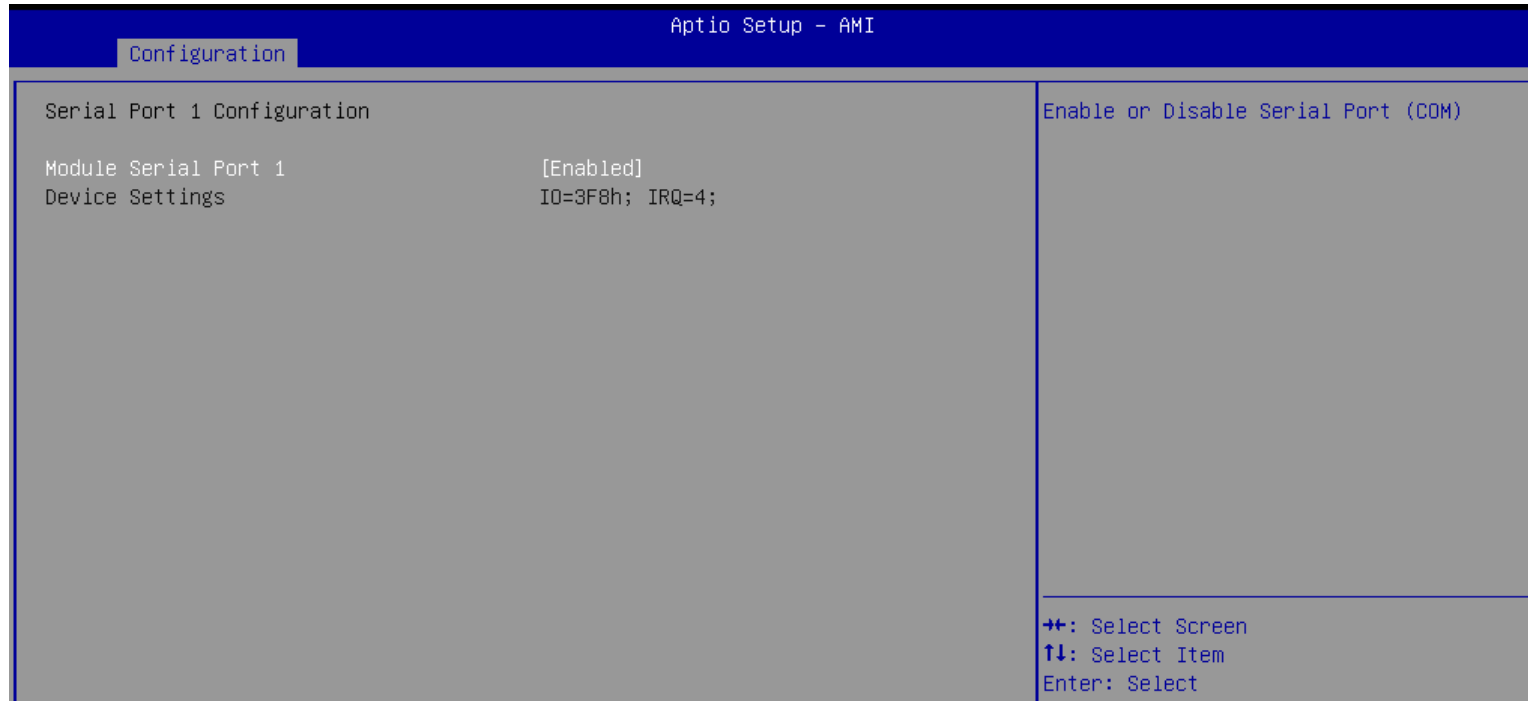

Feature	Description	Options
Module Serial Port 1/2	Enable or Disable Serial Port (COM)	★Enabled, Disabled

- **H/W Monitor**
Monitor hardware status

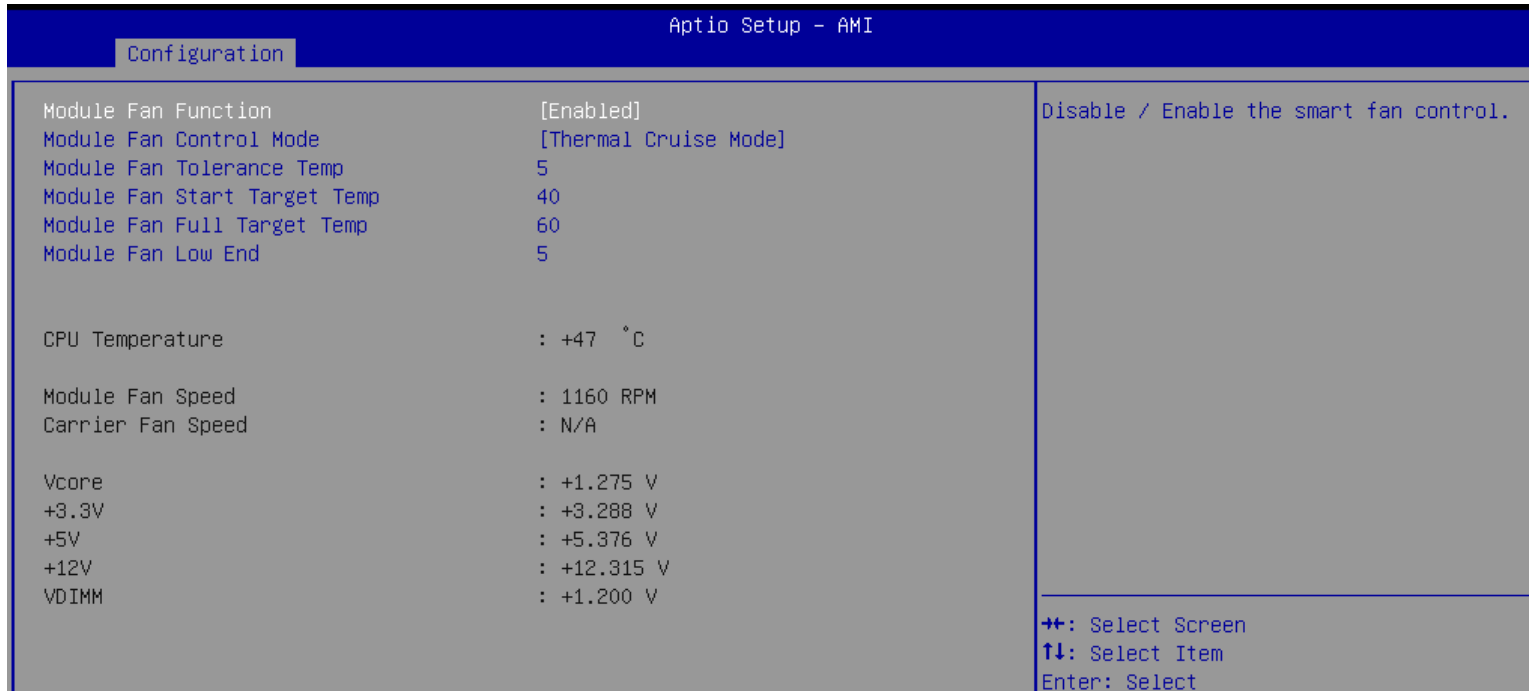

Feature	Description	Options
Module Fan Function	Disable/Enable the Smart Fan Control.	★Enabled ,Disabled
Module Fan Control Mode	Select Smart Fan Control Mode.	★Thermal Cruise Mode ,Fan Control Mode
Module Fan Tolerance Temp	In Thermal Cruise Mode: tolerance of target temperature.	★5
Module Fan Start Target Temp	In Thermal Cruise Mode: start temperature.	★40
Module Fan Full Target Temp	In Thermal Cruise Mode: full speed Temperature.	★60
Module Fan Low End	In Thermal Cruise Mode: low end of fan speed (0-100%)	★5

- **Serial Port Console Redirection**
Serial Port Console Redirection

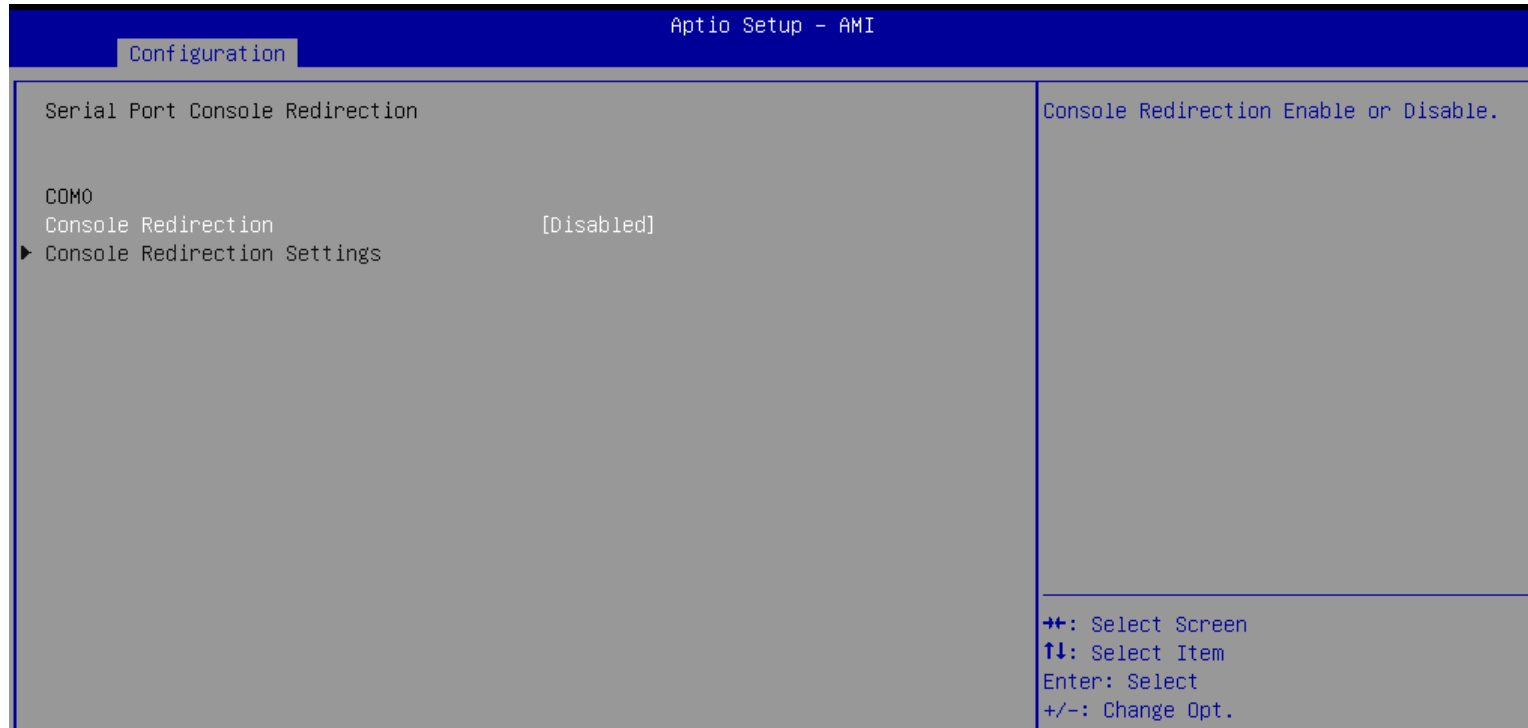

Feature	Description	Options
Console Redirection	Console Redirection Enable or Disable	★Disabled, Enabled

- **COM0 Console Redirection Settings**

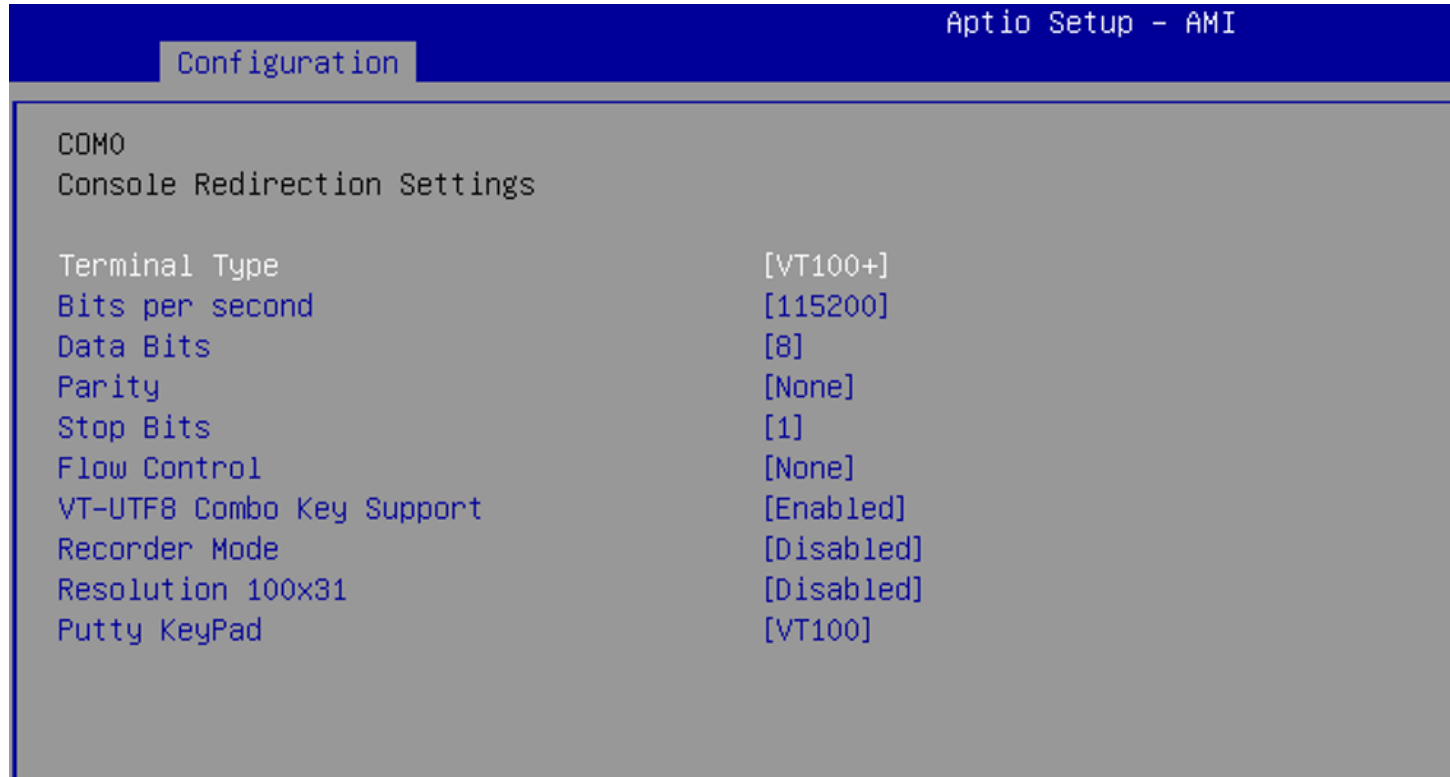

Feature	Description	Options
Terminal Type	Emulation: ANSI: Extended ASCII char set. VT100: ASCII char set. VT100+: Extends VT100 to support color, function keys, etc. VT-UTF8: Uses UTF8 encoding to map Unicode chars onto 1 or more bytes.	★VT100+, VT100,VT-UTF8, ANSI
Bits per second	Select Serial port transmission speed. The speed must be matched on other side. Long or noisy lines may require lower speeds.	★115200, 9600, 19200, 38400, 57600
Data bits	Data bits	★8, 7
Parity	A parity bit can be sent with the data bits to detect some transmission errors. Even: parity bit is 0 if the num of 1's in the data bits is even. Odd: parity bit is 0 if num of 1's in the data bits is odd. Mark: parity bit is always 1. Space parity bit is always 0. Mark and Space Parity do not allow for error detection. They can be used as an additional data bit.	★None, Even, Odd, Mark, Space
Stop Bits	Stop bits indicate the end of a serial data packet. (A start bit indicates the beginning). The standard setting is 1 stop bit. Communication with slow devices may require more than 1 stop bit.	★1,2
Flow Control	Flow control can prevent data loss from buffer overflow. When sending data, if the receiving buffers are full, a 'stop' signal can be sent to stop the data flow. Once the buffers are empty, a 'start' signal can be sent to re-start the flow. Hardware flow control uses two wires to send start/stop signal.	★None, Hardware RTS/CTS
VT-UTFB Combo Key Support	Enable VT-UTF8 Combination Key Support for ANSI/VT100 terminals	★Enabled, Disabled
Recorder Mode	With this mode enabled only text will be sent. This is to capture Terminal data.	★Disabled, Enabled
Resolution 100x31	Enables or disables extended terminal resolution	★Disabled, Enabled
Putty KeyPad	Select FunctionKey and KeyPad on Putty	★VT100, LINUX,XTERMR6, SCO,ESCN,VT400

- **EC Firmware Update**

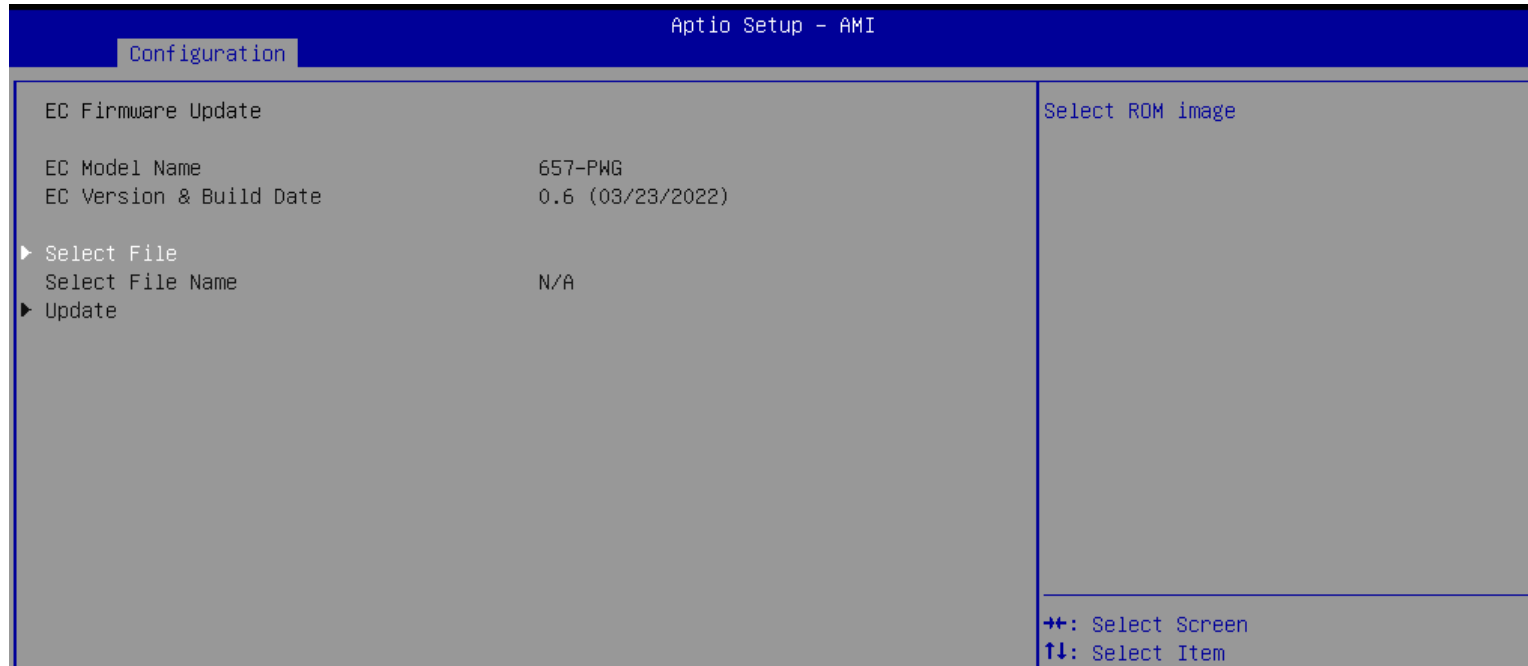

Feature	Description	Options
Select File	Select ROM image	

- **Intel® Ethernet Controller (3) I225-LM**
Configure Gigabit Ethernet device parameters.

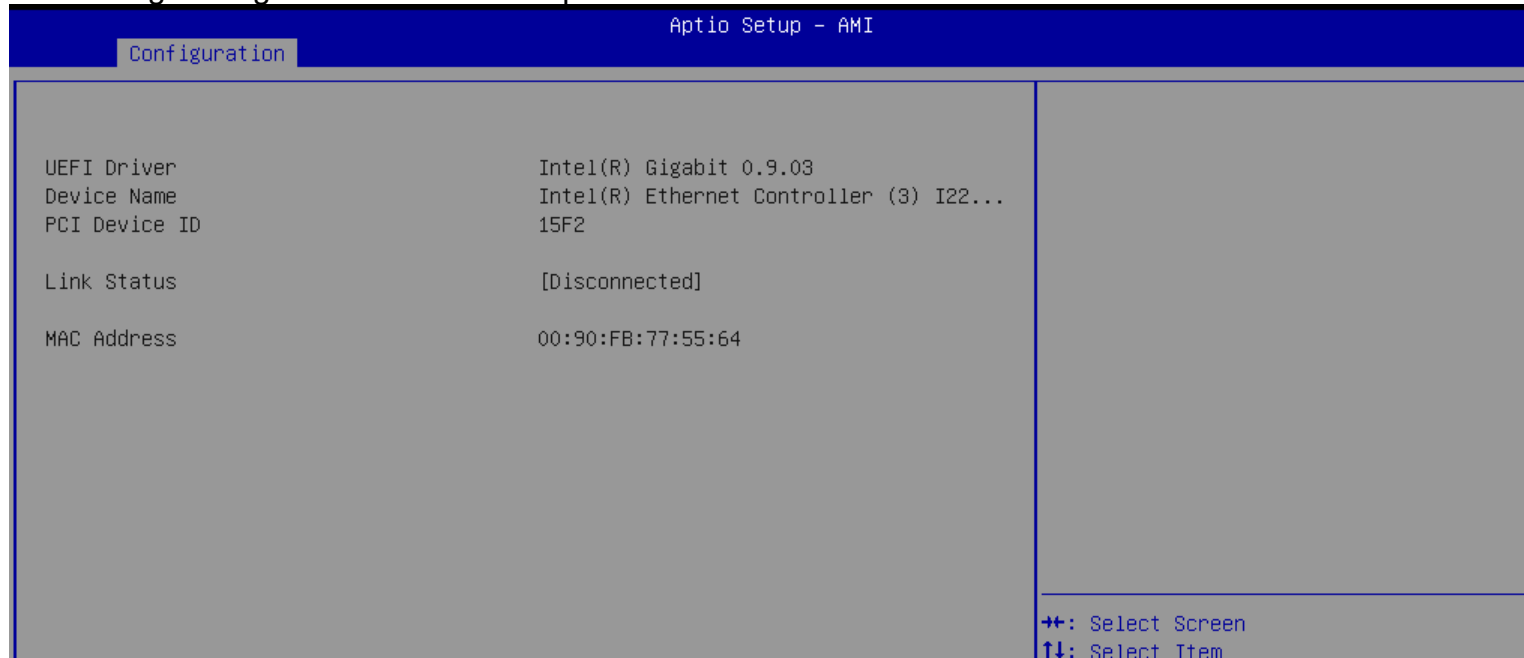

7.2.3 Security

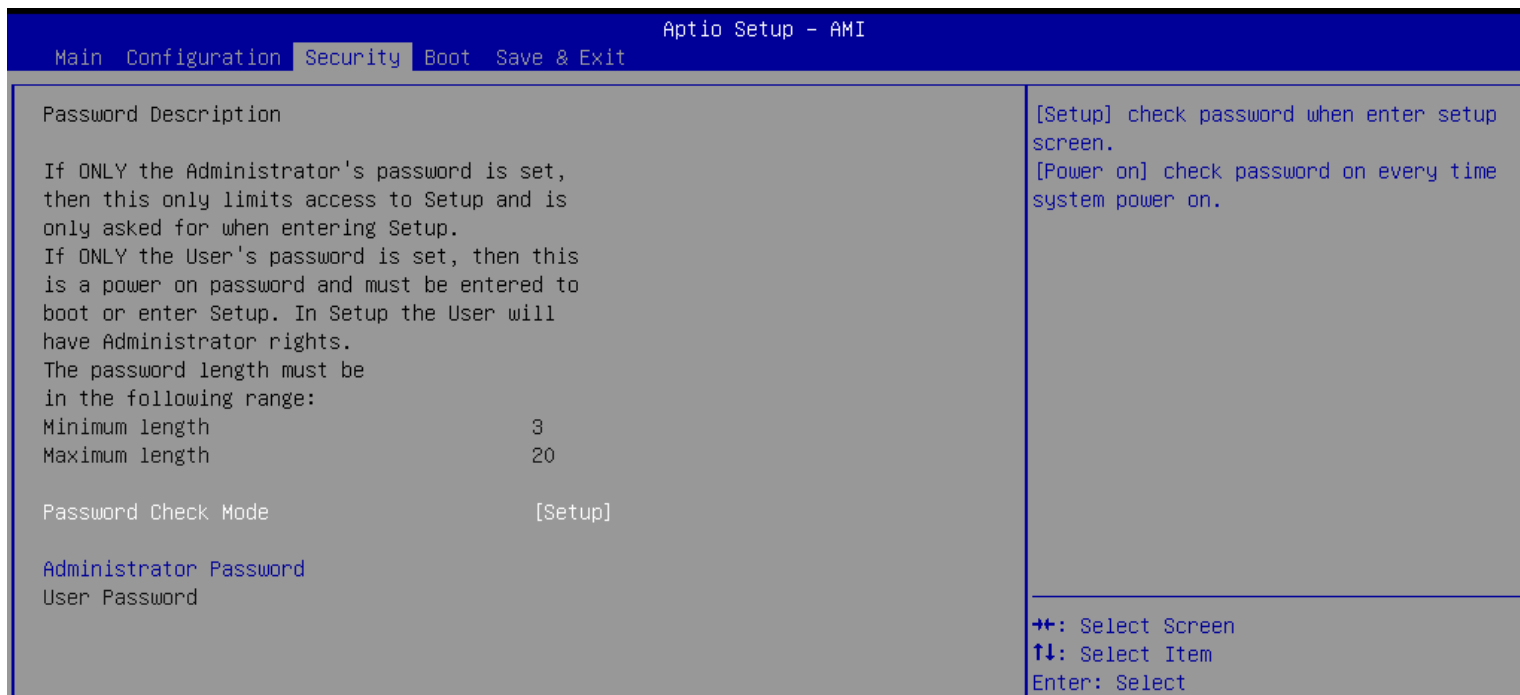

Feature	Description	Options
Password Check Mode	[Setup] check password when enter setup screen. [Power on] check password on every time system power on.	★Setup, Power on
Administrator Password	Set Administrator Password	

7.2.4 Boot

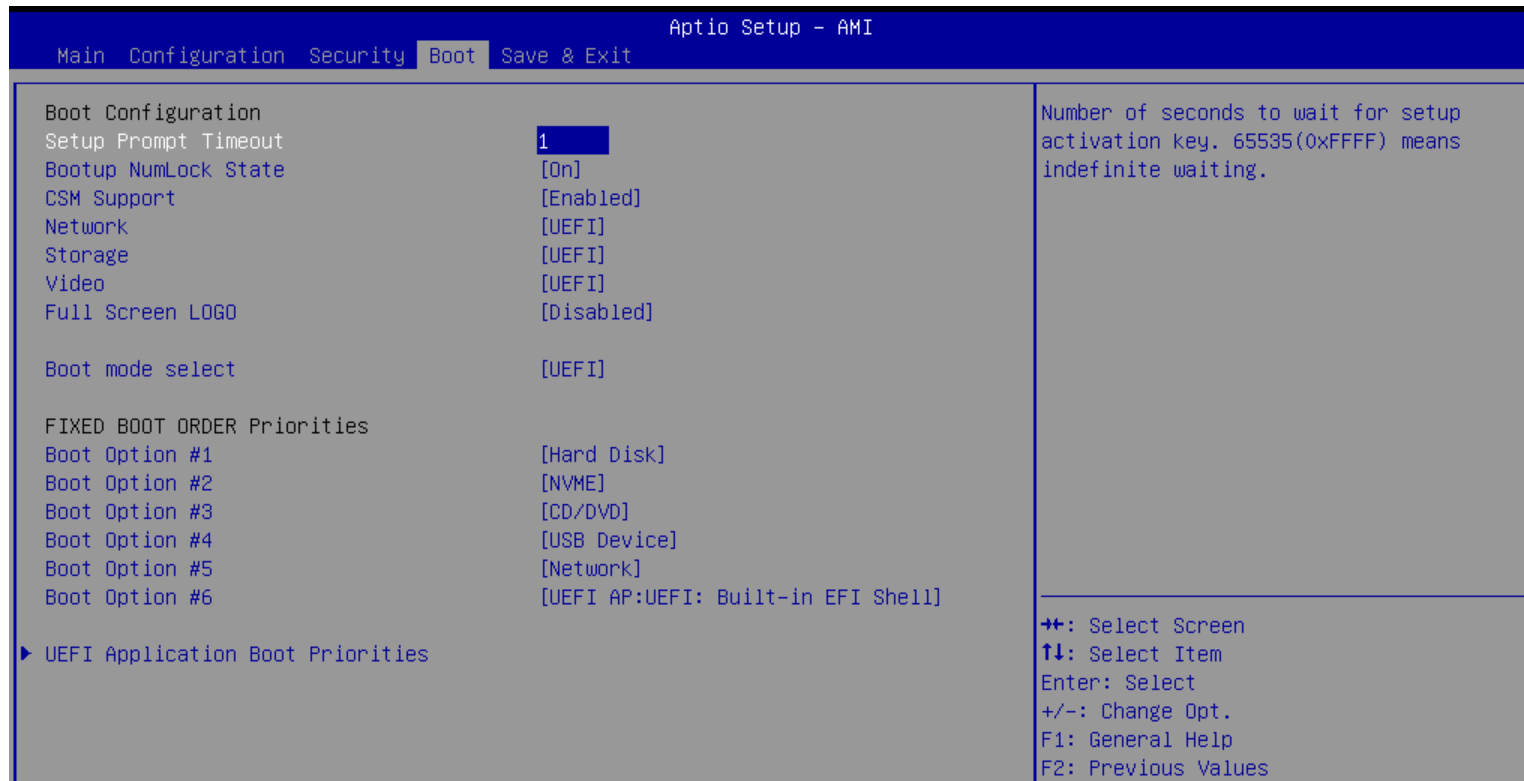

Feature	Description	Options
Setup Prompt Timeout	Number of seconds to wait for setup activation key. 65535(0xFFFF) means indefinite waiting.	★1
Bootup NumLock State	Select the keyboard NumLock state	★On, Off
CSM Support	Enable/Disable CSM support	★Disabled
CSM Support [Enabled]		
Network	Controls the execution of UEFI and Legacy Network OpROM.	★UEFI ,Do not launch, Legacy
Storage	Controls the execution of UEFI and Legacy Storage OpROM.	★UEFI ,Do not launch, Legacy
Video	Controls the execution of UEFI and Legacy Video OpROM.	★UEFI ,Do not launch, Legacy
Full Screen LOGO	Enables or disables Quiet Boot option and Full screen Logo.	★Disabled, Enabled
Boot mode select	Select boot mode LEGACY/UEFI	★UEFI ,Legacy
Boot Option #1~6	Sets the system boot order	★Hard Disk, NVME, CD/DVD, USB Device, Network, UEFI AP: UEFI: Built-in EFI Shell, Disabled
UEFI Application Boot Priorities	Specifies the Boot Device Priority sequence from available UEFI Application	

7.2.5 Save & Exit

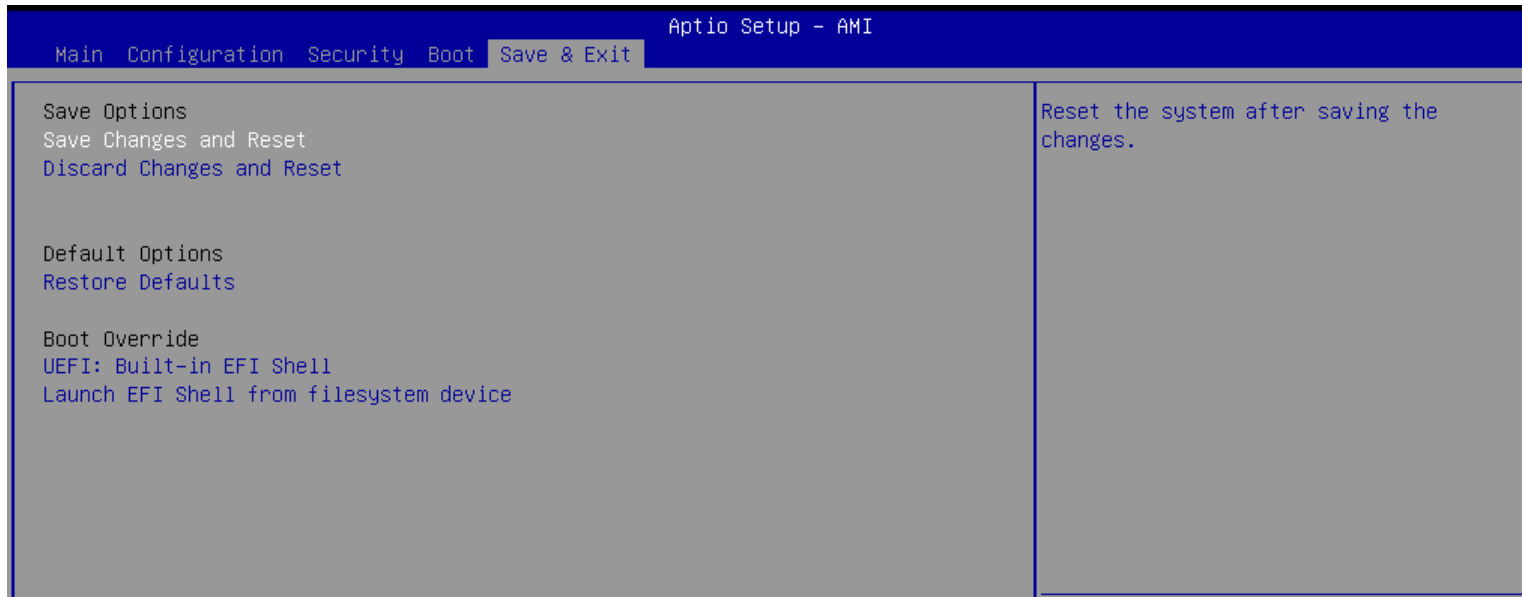

Feature	Description	Options
Save Changes and Reset	Reset the system after saving the changes.	
Discard Changes and Reset	Reset system setup without saving any changes.	
Restore Defaults	Restore/Load Default values for all the setup options.	
UEFI: Built-in EFI Shell		
Launch EFI Shell from filesystem device	Attempts to Launch EFI Shell application (Shell.efi) from one of the available filesystem devices.	

8 BIOS / EC Update

PCOM-B880VG2 only support BIOS/EC update under UEFI shell environment, refer the following step, please.

● BIOS update

Step 1. Unzip update file to the USB DOK (USB DOK must be FAT or FAT32 format)

Step 2. Make sure “Boot mode select” item is “UEFI” in the BIOS “Boot” page

Shown as below picture

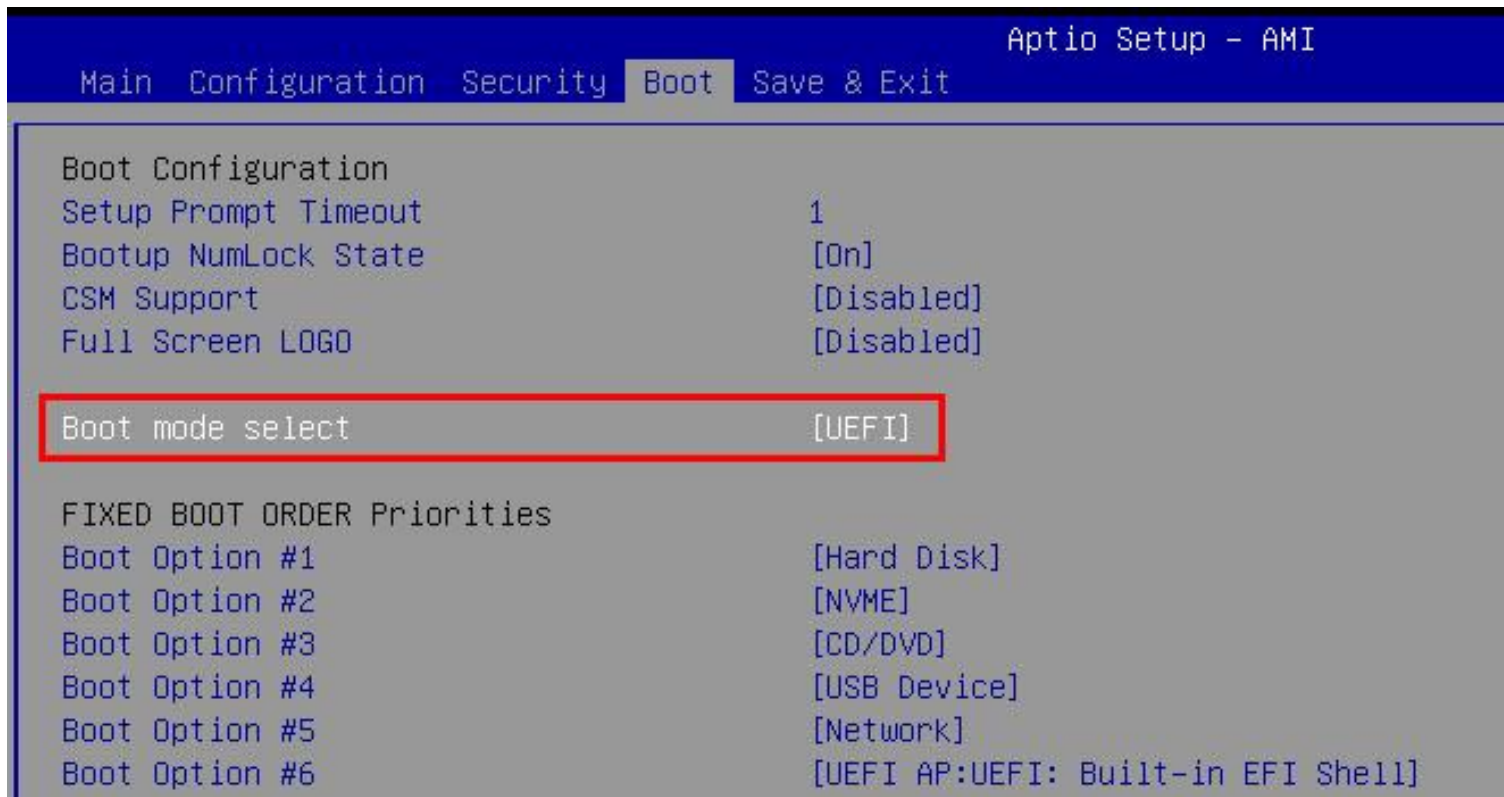

Step 3. Plug the USB DOK on the target system and select “Built-in EFI Shell” in the BIOS “Save&Exit” page

Shown as below picture

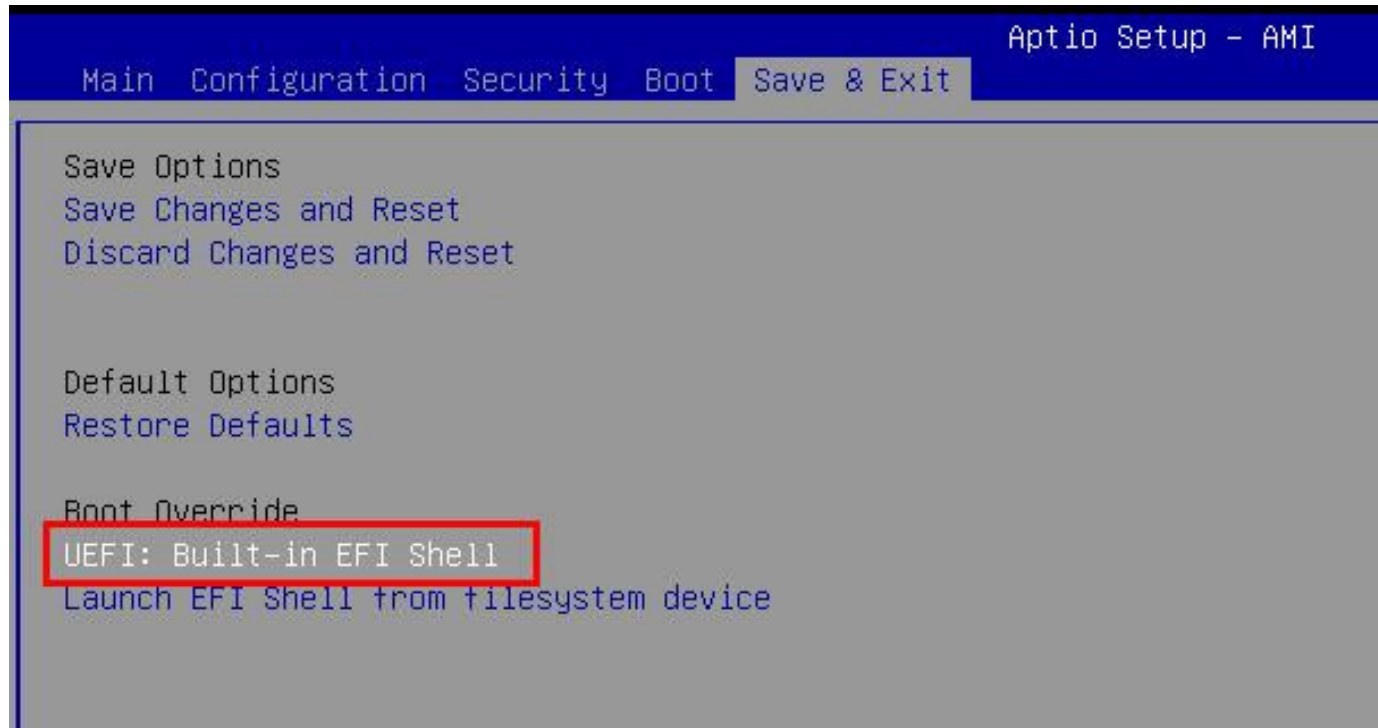

Step 4. Under the UEFI shell, change prompt to your USB DOK, the below example is “**fs0:**”

Step 5. Then change the folder with updated file and use command: “**update**” and press enter

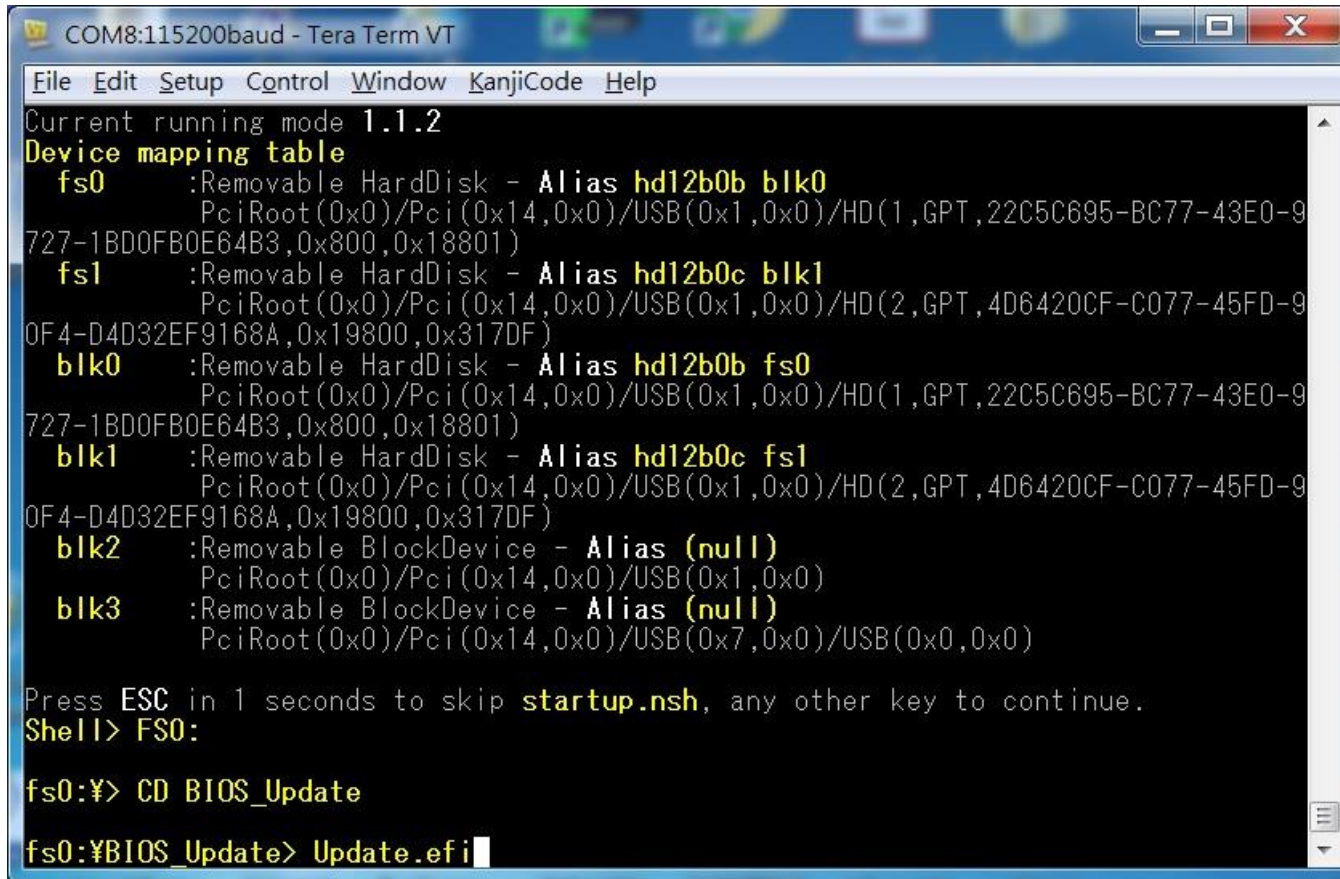

```
COM8:115200baud - Tera Term VT
File Edit Setup Control Window KanjiCode Help
Current running mode 1.1.2
Device mapping table
fs0      :Removable HardDisk - Alias hd12b0b blk0
         PciRoot(0x0)/Pci(0x14,0x0)/USB(0x1,0x0)/HD(1,GPT,22C5C695-BC77-43E0-9
727-1BD0FB0E64B3,0x800,0x18801)
fs1      :Removable HardDisk - Alias hd12b0c blk1
         PciRoot(0x0)/Pci(0x14,0x0)/USB(0x1,0x0)/HD(2,GPT,4D6420CF-C077-45FD-9
0F4-D4D32EF9168A,0x19800,0x317DF)
blk0     :Removable HardDisk - Alias hd12b0b fs0
         PciRoot(0x0)/Pci(0x14,0x0)/USB(0x1,0x0)/HD(1,GPT,22C5C695-BC77-43E0-9
727-1BD0FB0E64B3,0x800,0x18801)
blk1     :Removable HardDisk - Alias hd12b0c fs1
         PciRoot(0x0)/Pci(0x14,0x0)/USB(0x1,0x0)/HD(2,GPT,4D6420CF-C077-45FD-9
0F4-D4D32EF9168A,0x19800,0x317DF)
blk2     :Removable BlockDevice - Alias (null)
         PciRoot(0x0)/Pci(0x14,0x0)/USB(0x1,0x0)
blk3     :Removable BlockDevice - Alias (null)
         PciRoot(0x0)/Pci(0x14,0x0)/USB(0x7,0x0)/USB(0x0,0x0)

Press ESC in 1 seconds to skip startup.nsh, any other key to continue.
Shell> FS0:

fs0:¥> CD BIOS_Update

fs0:¥BIOS_Update> Update.efi
```

Step 6. The updating process will start and show the updating progress

Step 7. Please power off and restart the system once updating finished

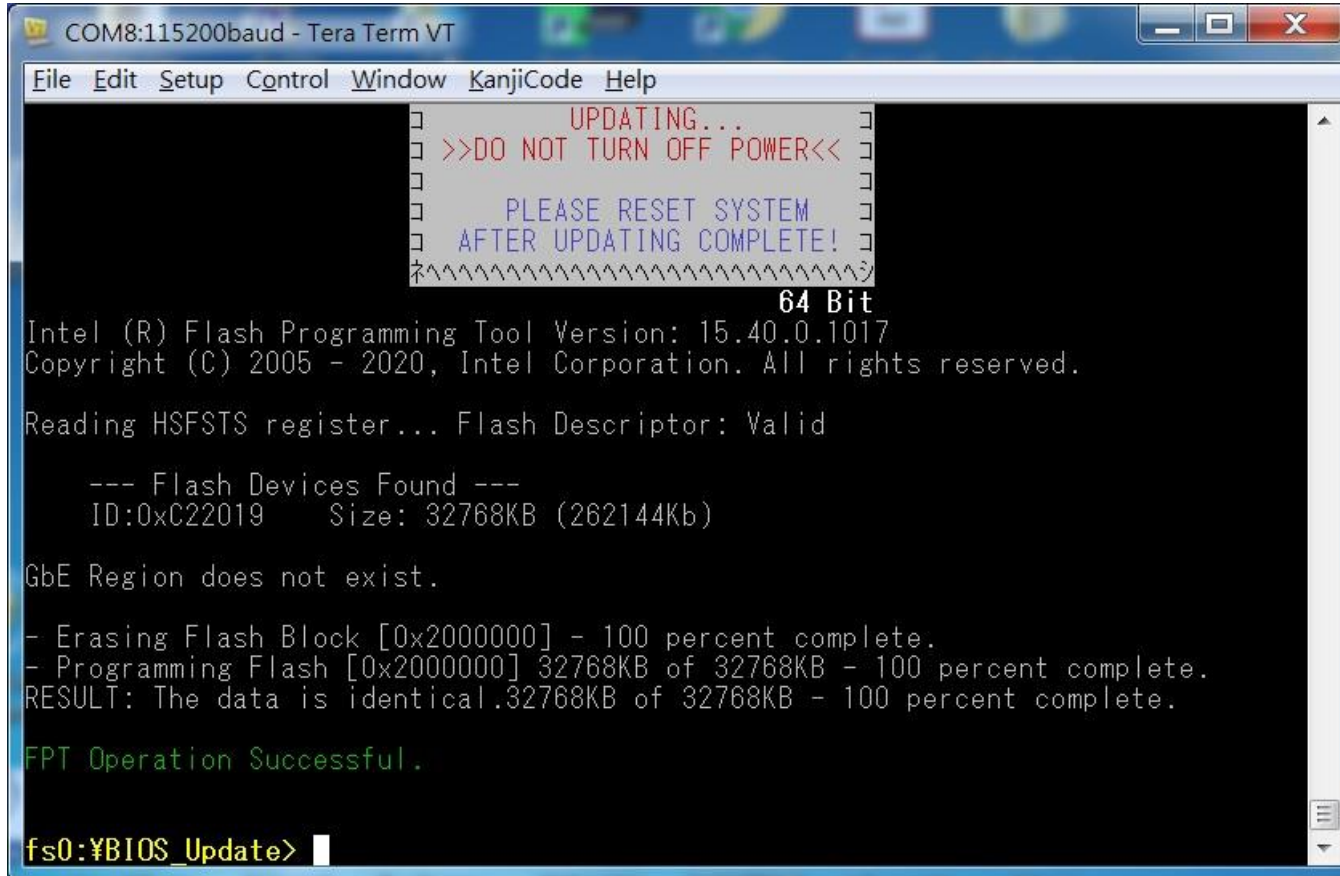

```
COM8:115200baud - Tera Term VT
File Edit Setup Control Window KanjiCode Help
      UPDATING...
      >>DO NOT TURN OFF POWER<<
      PLEASE RESET SYSTEM
      AFTER UPDATING COMPLETE!
      ~~~~~
                                64 Bit
Intel (R) Flash Programming Tool Version: 15.40.0.1017
Copyright (C) 2005 - 2020, Intel Corporation. All rights reserved.

Reading HSFSTS register... Flash Descriptor: Valid

--- Flash Devices Found ---
  ID:0xC22019   Size: 32768KB (262144Kb)

GbE Region does not exist.

- Erasing Flash Block [0x2000000] - 100 percent complete.
- Programming Flash [0x2000000] 32768KB of 32768KB - 100 percent complete.
RESULT: The data is identical.32768KB of 32768KB - 100 percent complete.

FPT Operation Successful.

fs0:¥BIOS_Update>
```

(BIOS updating finished)

● EC update

Step 1. Unzip EC binary file to the USB DOK (USB DOK must be FAT or FAT32 format)

Step 2. Select “EC Firmware Update” item in BIOS setup menu

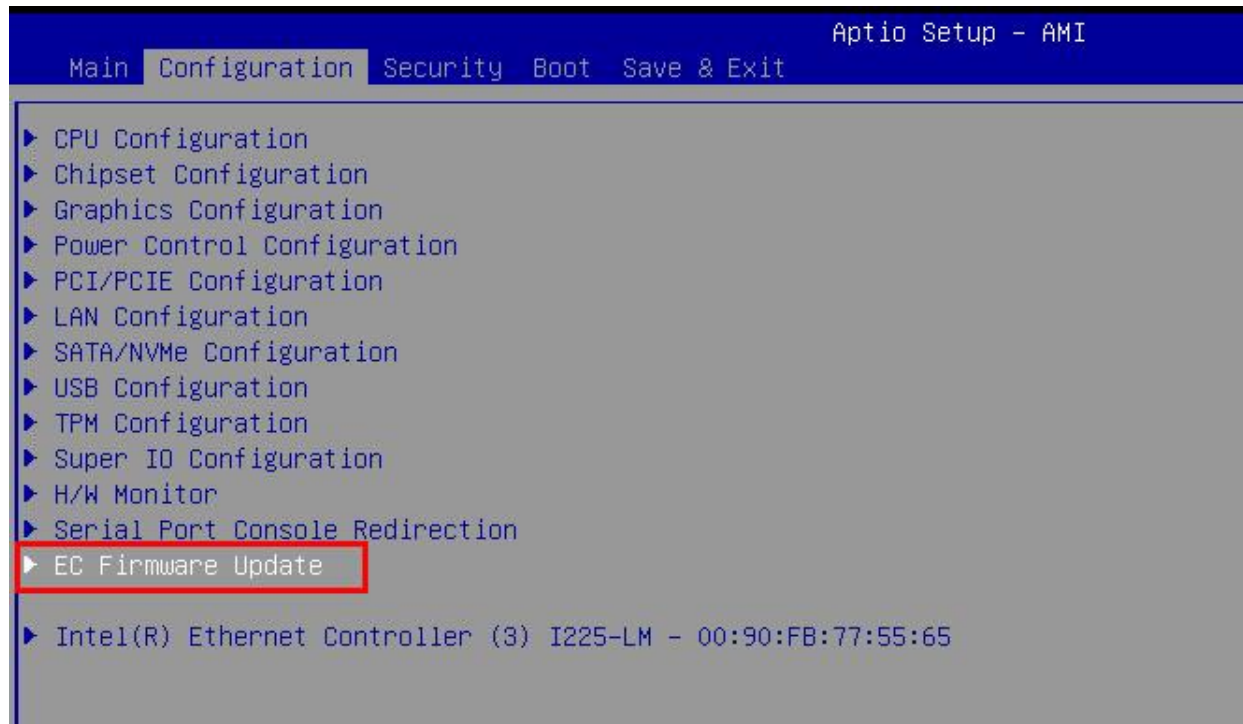

Step 3. Select EC binary file by option item shown as below

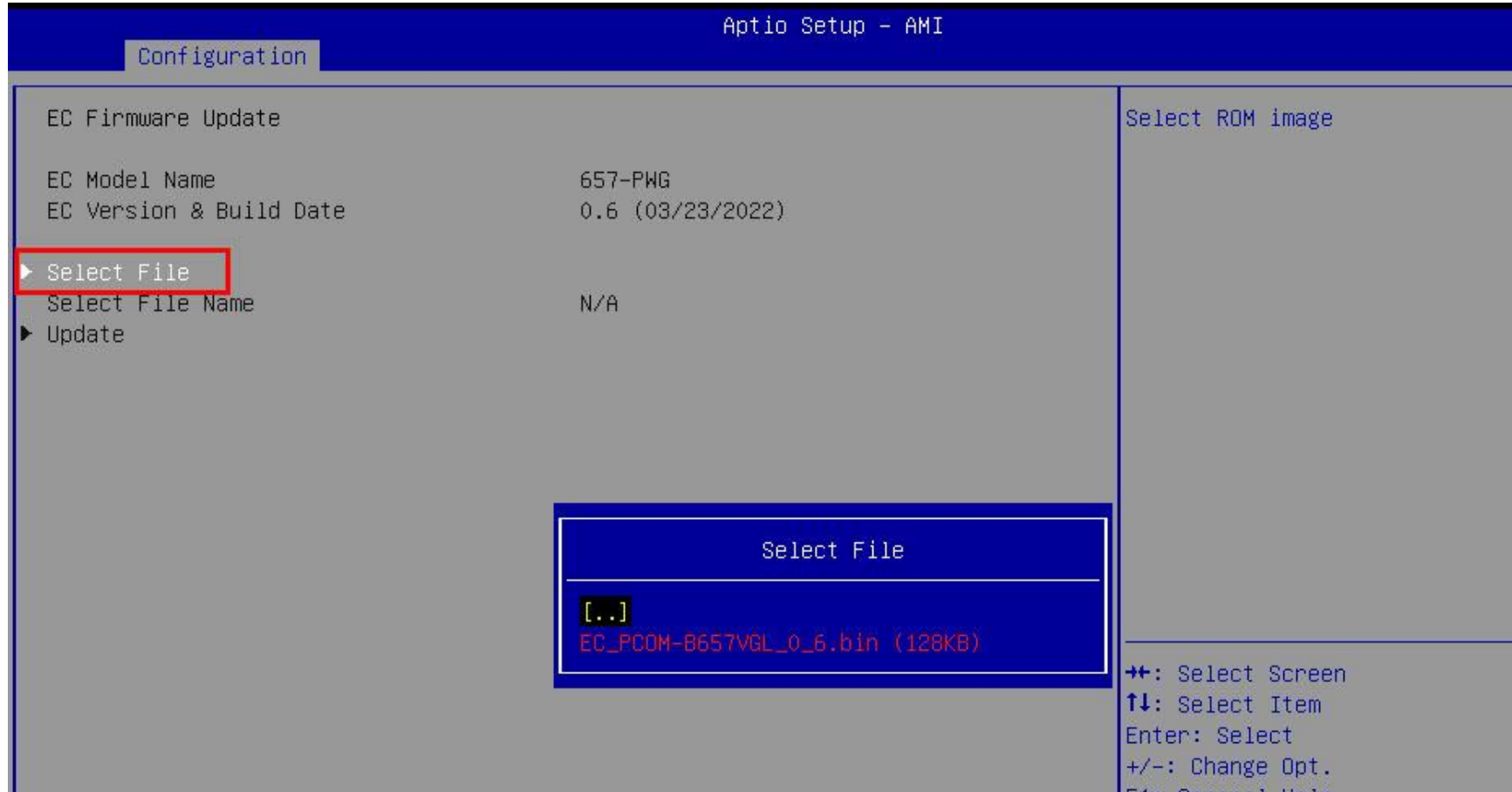

Step 4. Select "Yes" to start EC update (Please don't turn off power during firmware update)

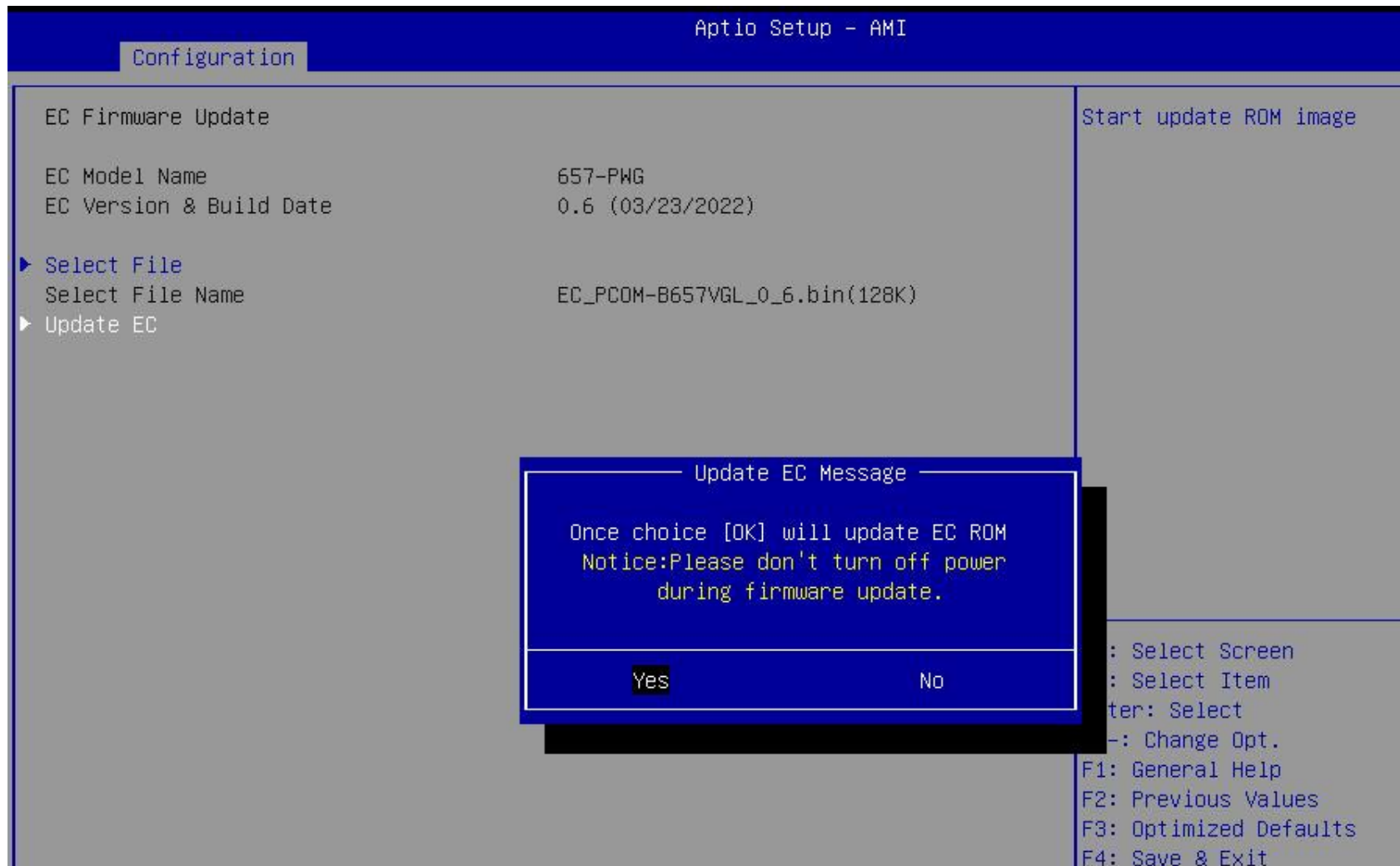

Step 5. Turn off power to make system into G3 status once updating finished, then power on the system

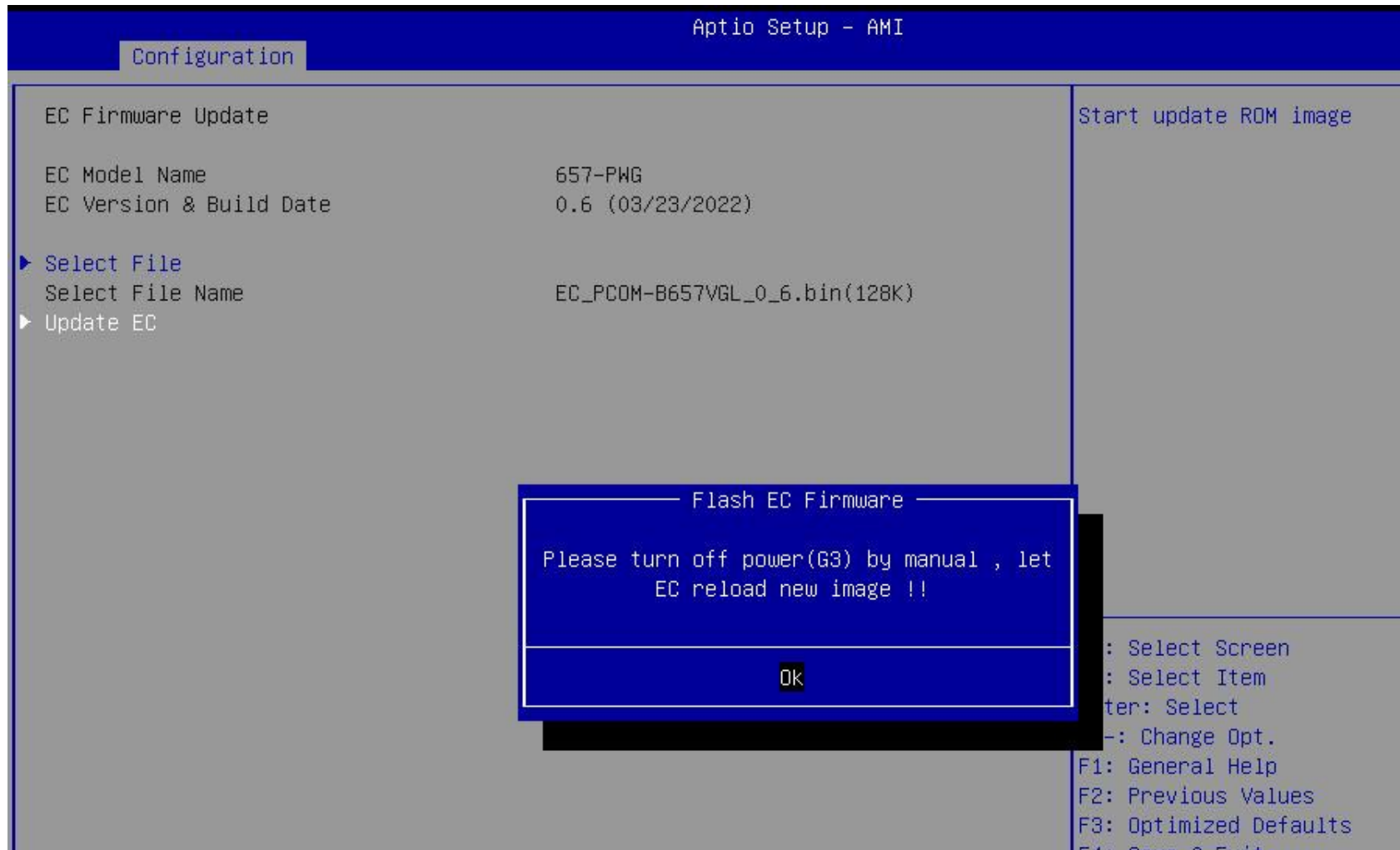

9 PORTWELL Software Tool

PORTWELL Evaluation Tool (PET)

The PORTWELL Evaluation Tool (PET) is an API which PORTWELL's customers can access the GPIO, I2C, SMBus, etc under Windows and Linux OS. For further information please contact PORTWELL.

PORTWELL BIOS web Tool (PBT)

The PORTWELL BIOS web Tool (PBT) is a brand new on-line utility innovated by PORTWELL. PBT now is available for PORTWELL's premiere customers who are able to **add customized BIOS logo** and **change BIOS default settings** on American Megatrends Inc. (AMI) BIOS. Please contact PORTWELL for further information.

PORTWELL EC Auto Test Tool (PECAT)

The PORTWELL EC Auto Test Tool (PECAT) is a brand new utility innovated by PORTWELL. PECAT now is available for PORTWELL's premiere customers, who are able to **Test Embedded Controller Function** in UEFI Mode. Please contact PORTWELL for further information.

10 Packaging Information

PCOM-B880VG2's packaging specification will follow the Portwell standard style.

Package	Appearance	Size
Anti-Static bubble bag		180x130mm
White Paper Box		210x150x40mm
Shipping Box (10 pcs White paper box)		595x300x185mm

Table 13 Packaging information

11 Industry Specifications

The list below provides links to industry specifications that apply to PORTWELL modules.

Low Pin Count Interface Specification, Revision 1.0 (LPC) <http://www.intel.com/design/chipsets/industry/lpc.htm>

Universal Serial Bus (USB) Specification, Revision 2.0 <http://www.usb.org/home>

PCI Specification, Revision 2.3 <https://www.pcisig.com/specifications>

Serial ATA Specification, Revision 3.0 <http://www.serialata.org/>

PICMG® COM Express Module™ Base Specification <http://www.picmg.org/>

PCI Express Base Specification, Revision 3.0 <https://www.pcisig.com/specifications>