

# Industrial Panel PC Solution Guide





# About Portwell

Portwell, Inc. was founded in 1993 and entered the Industrial PC market in 1995 by developing single-board computers. Today, our continuous development of leading-edge products has not only resulted in strong growth in market shares and revenue but established Portwell as a major worldwide supplier of specialty computing application platforms and services. Portwell, Inc. is an

Associate member of the Intel® Partner Alliance. From modular components to market-ready systems, Intel® and the 250+ global member companies of the Intel® Partner Alliance provide scalable, interoperable solutions that accelerate deployment of intelligent devices and end-to-end analytics. Portwell, Inc. is also a member of the selected group of Intel® Applied Computing Platform Providers (IACPP), as well as Advanced Telecom Computing Architecture (ATCA) and an executive member of PCI Industrial Computer Manufacturing group (PICMG).



Portwell Engine (PE) Building

Portwell, Inc. has worldwide operations in the U.S.A., Taiwan, Japan, Korea, China, Netherlands, United Kingdom, Germany and India. Whether you are working on a computer board or turnkey system, Portwell is the perfect partner to help you deliver your products to the market on time as well as maintain longevity of product. With 28 years experience in the design and manufacturing of specialty computer boards and systems, Portwell not only provides a one-stop resource for off-the-shelf products, but also supplies custom-built solutions and a global logistics services to suit your needs.

Portwell OEM and ODM solutions satisfy your needs in retail automation, medical equipment, industrial automation, infotainment, communication, and network security markets.

Encouraged by our flexible business support, manufacturing excellence, and compliance with high quality and environmental standards such as ISO 14001/13485/9001/45001/28000, OHSAS and RoHS, customers have taken advantage of our dedicated and sophisticated engineering resource to satisfy their requirements for the design, manufacturing and logistics of application-specific computer boards, customized computer chassis, and specific computer system configurations. Whether you are working on a Medical Single Board Computer or Internet Security Appliance, Portwell is, again, the perfect partner to help you deliver your products to the market on time and stay one step ahead of the competition.

Portwell is famous for her platform service that could offer the following benefits to customers.

#### ■ Complete Product Portfolio

Select from our full range of both off-the-shelf and versatile custom solutions to scale your products. Portwell provides not only board-level products but also peripheral-level and complete system solutions.

#### ■ Implement Latest Intel Technology

Portwell delivers cutting-edge solutions not only to meet and exceed the demand for the newest technologies, but also the need for greater product life cycles. Since partnering with Intel in 1999, and with streamline access to the latest Intel technologies and roadmaps, Portwell delivers superior products to meet your needs.

#### ■ Faster Time-to-Market

Portwell's experienced engineers, complete product solutions, global operation and flexible business service help you meet the time-to-market requirement and reduce your new product introduction cycles as well as the costs of conducting business.

#### ■ Leading Edge Innovator

Portwell is committed to product and solution innovation. We have a complete variety of proof-of-concept designs with Intel and we are also a leader in offering the latest technologies to the market.

#### ■ Committed to Customer Satisfaction

Portwell maintains high expectations in a determined pursuit of commitment to continuously improve our products and services in order to satisfy and exceed our customers' needs.

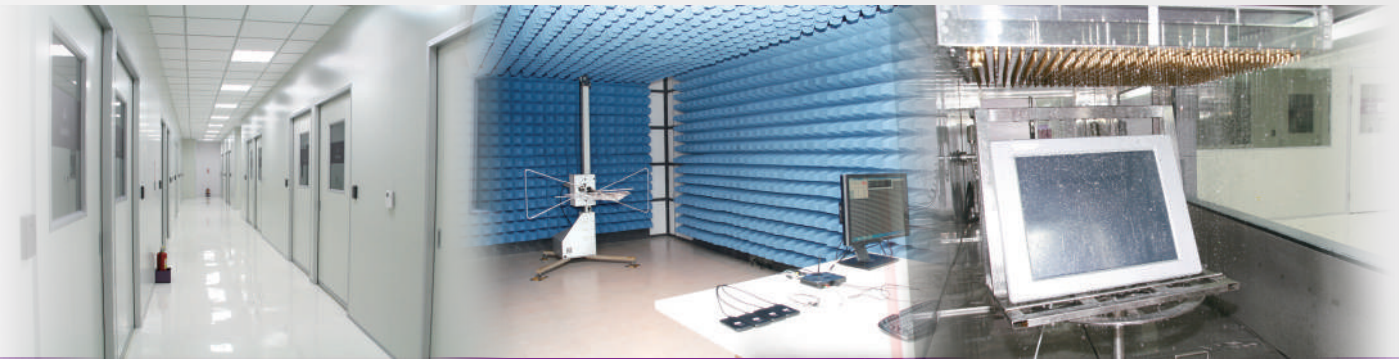

Consulting • Design • Product • Manufacturing • Logistics



Portwell is proud of the technology service it provides to our partners. These services include complete service-demand consulting, product development, advanced design, quality production and global logistics.

#### Share for Success

Portwell is eager to share its industrial know-how with customers via our online consulting. This feature enables customers to obtain suitable or customized solutions quickly and efficiently.

#### Design, Develop, and Deliver

- We design, develop and deliver our customer requirements, such as production, reliability, stability, cost-effectiveness, and longevity of product.
- Our experienced and sophisticated engineering capabilities include electronic, mechanical, firmware and system integration expertise.

#### Portwell Manufacturing Excellence

- We supply component inventory management with automation.

- In-house SMT lines and PCB assembly and functional testing.
- In-house system integration and testing.
- ISO 14001 and ISO 9001 certified manufacturing facilities (89,000 sq. ft. in Taipei).
- Flexible production capability.

#### Portwell Global Presence

- Single contact window, global support.
- Sales and technical support teams are available through Portwell worldwide offices in the U.S.A., Taiwan, Japan, China, Netherland, United Kingdom, and India.
- Customer-centric service and support.



# System Production Flow



## IPQC

Verifies that all the production processes are completed correctly and accordingly to specification.



## Visual Inspection

Once systems have been assembled, they will have already been visually inspected. Our inspectors ensure all components and accessories are assembled properly and follow SOP before testing.



## Assembly

Makes certain that all the system components were assembled properly (Main board, Cable, Fan, HDD, etc.)

## Shipping

In order to meet the demands of storage, transportation, loading and unloading the products mechanically, our pallet stretch wrap machine is designed to enhance production efficiency and prevent damage to the products during transportation.



## OQC

To implement QC inspection procedure on packaged and finished goods, OQC has the MIL-STD 105E Table. QC staff conducts sampling according to required sampling by quantity.

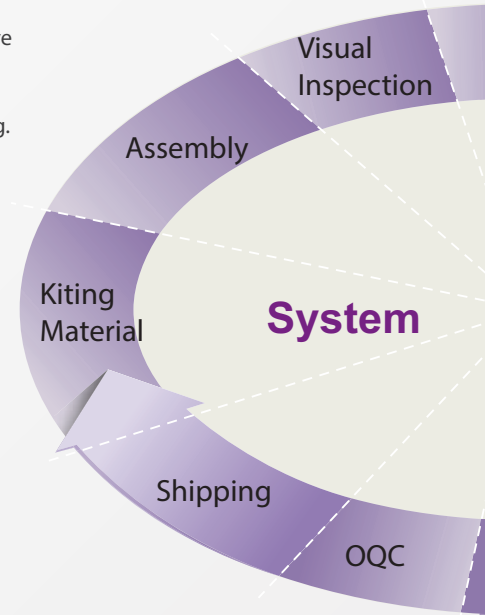

## Certifications

ISO 45001 is a standard which represent her highly regards labors' safety, the commitment to employees' health management and continuously improvement to the company and society.



## Certifications

The ISO 14000 environmental management standards exist to help organizations minimize how their operations negatively affect the environment and comply with applicable laws, regulations, and other environmentally oriented requirements and continually improve in the above.



### Basic Function Test

In order to ensure the system product is able to boot up by Dynamic Burn-In, 100% of the system products are tested for electronic functionality via a Basic Function Testing after assembly.



### Dynamic Burn In Test

DBI is the test used before the product is shipped out. The purpose is to screen possible weaknesses and failures which affect its reliability under different environments.



### Advanced Function Test

This procedure is to ensure the quality and functionality of the system product after the Burn-in test.

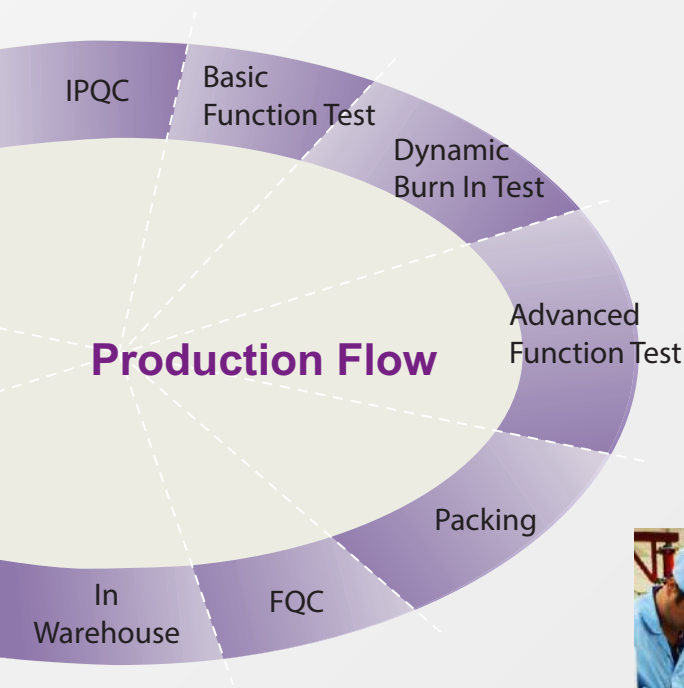

### Packing

We inspect the product for external defectiveness. Once they have passed, we then collocate all accessories into plastic bags then proceed with boxing and labeling.



### FQC

Finished and packed goods are placed in this area for inspection; the FQC department will inspect finished goods based on standard procedures.



### Certifications

ISO 9001 deals with the fundamentals of quality management systems, including the eight management principles on which the family of standards is based.



### Certifications

ISO 13485 is an ISO standard that represents the requirements for a comprehensive management system for the design and manufacture of medical devices.

# Our Philosophy in Panel PC

Before every model of Portwell's Panel PC comes into exist, we make sure these systems can create as much value as they can, that is, not only to Portwell, but also to our partners, customers, end users and our society. Bearing our core philosophy in mind, Portwell is dedicated to providing IPC customers with products of TFT-LCD display related industrial grade Panel PC with Refinement, Affordability and Creativity.



## Refinement, Affordability and Creativity

**Refinement** - In addition to an industrial computer system, Portwell tries to make Panel PC an exquisite craft in slim, compact and light style with aesthetic design to enhance user experience. With abundant researching and developing capacity, Portwell can optimize component choosing, board placement and mechanical design, bringing industrial panel systems to a new era.

**Affordability** - By optimizing and simplifying system and mechanical design, Portwell creates panel systems that can especially meet the extreme expectations in harsh industrial environment but remain competitive and value optimized pricing. Therefore, everyone in this society can enjoy and benefit from the convenient and smart lives thanks to fair cutting-edge technology.

**Creativity** - As an Associate member of the Intel® IoT Solution Alliance, Portwell always adopts the latest Intel® platform to create the best industrial panel system for customers. At the same time, we focus on future trend and customer feedbacks to continuously improve our products and services. Therefore, Portwell's Panel PC always stands out in the market.

## PPC Key Features

In order to make a R.A.C industrial Panel PC, Portwell, with more than 20 years experience, cares about....

### ▪ Radiation is no longer a concern!

Before released to sale, Portwell's Panel PC has passed safety regulations by EEA and FCC Class A requirements, which indicate the system is suitable for office or factory use since it has low radio frequency that would not cause harmful interference and accept interference received.

### ▪ IP Certification proves our outstanding technology.

IP rating classifies the degrees of protection against the intrusion of solid objects, dust, accidental contact and water in electrical enclosures. Portwell's Panel PC has proven itself as a rugged system by passing IP65 or IP54, ensuring its reliability and durability in harsh environment.

### ▪ Explore the limit of your system.

Vibration and shock test simulates the systems experiencing vibrations during transportation, installation and field environments to verify stability and withstand vibration. By passing critical test, Portwell's Panel PC proves its ability to meet expectations in rough environment.

### ▪ Aluminum makes the greatest Portwell Panel PC.

In addition to a good electricity and heat conductor, Aluminum naturally generates a protective oxide coating and is highly corrosion resistive. Besides, the eco-friendly material also matches our commitment to Mother Earth; thus, Portwell makes Panel PC in aluminum for front frame but it can be easily modified into a stainless Panel PC as well.



# Rugged



▪ **Don't let MTBF of Fan constrain your Panel PC!**

Portwell's Panel PC aims at providing solutions that working reliably in difficult industrial environment. With fan-less design in our Panel PC, customers don't need to worry about excessive power consumption, reliability of fans, noise as well as dirt and system overheating due to unexpected fan failure.

▪ **Best thermal dissipation design ever.**

To realize a truly fan-less system, thermal simulation would be conducted at early stage of system design, significantly optimizing thermal dissipation efficacy as well as design efficiency. Measurable issues like components selection and placement, air flow vents, and heat-sinks has been considered thoroughly.

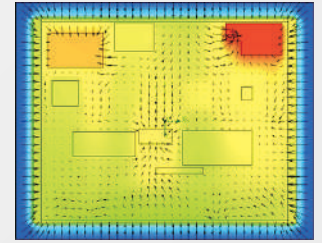
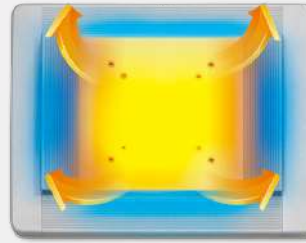

# Fan-less

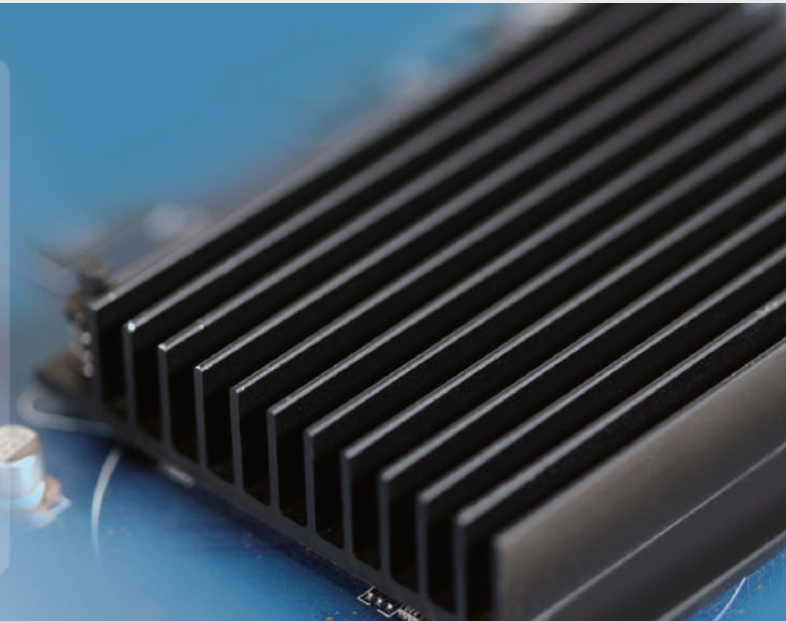
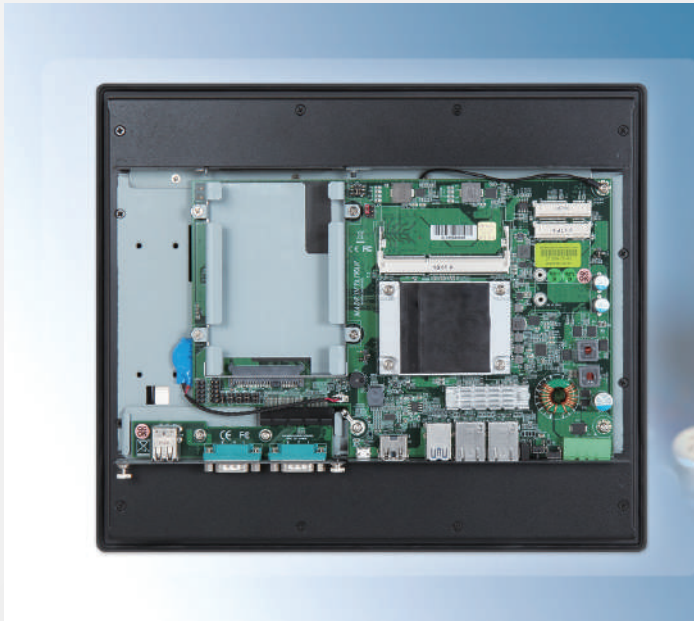

# Touch Panel



▪ **Aesthetic outlook design attracts users at the first sight.**

Instead of bulky appearance in traditional panel system, Portwell's Panel PC features stylish design: the true-flat surface, crystal screen, sleek bezel and refined edge draw everyone's attention immediately.

▪ **Panel box is designed in slim and light type.**

By leveraging Intel® low power consumption technology, Portwell's Panel PC is slim and compact in panel solution, making it more capable in all applications. Either to install a new HMI/MMI or to replace an old one in limited space; the space-saving and light panel systems can well-fitted.

▪ **Touch the cloud through resistive or P-CAP touch screen.**

More than a computer, Portwell's touch panel system aims at building a platform to link between human and machine. By adopting sensitive touch screen and panel of high brightness, Portwell would like to enhance user's experience; thus, user's can operate by intuition, making lives easier, smarter and more efficient.



# Target Market Applications



## Automation

Global Industrial PC market is driven by higher demand from global automated manufacturing market especially in developed countries. In developing countries too, labor-intensive industries are adopting IPC in order to reduce their dependence on labor while ensuring high output.

As the core control system in the production line, highly reliable and stable operation is the essential requirement. Unexpected working conditions like severe operating temperature, dusty factory environment and vibrating machines will push system's ability to the limit.

Before shipping, Portwell's Panel PC need to pass burn-in and advanced function tests that ensure system quality and functionality. All procedures are certified by ISO9001/ISO14001. Also, the fan-less design guarantees longer life time and the excellent vibration/shock resistance, IP65 certification, and wide temperature/voltage support protect systems from potential damage in different environments. Slim and compact design including mounting kits is good for space limited space. Various I/O ports enhance flexibility for application fields.



In transportation application fields, safety is always the highest concern. Systems, no matter serving as an in-vehicle infotainment or a control system, may encounter strong and continuous vibration or warm operating environment inside car, making system stability and reliability a big challenge.

Portwell's Panel PC is equipped with robust mechanical design and provides best ventilation with great thermal design while using in car. Low power components on small factor boards can fit into slimmer cabinet, and lead to a greener system as well as reduce utility expenses. With abundant experience in OEM/ODM projects, Portwell has the capacities to meet transportation application requirements including eMark and EN50155. Moreover, Portwell's Panel PC has passed high quality industrial tests including shock, vibration, drop tests and IP65/54 certification; thus, it proves itself be able to operate in harsh environment.

## Transportation



# POS and KIOSK

Touch panel is now everywhere such as POS, order taking machines, exhibit kiosks and gaming terminals. With a touch screen, users can operate panel systems by themselves; thus, the amount of clerks in a store can be reduced, saving a lot of time and labor costs. Moreover, it can as increase flexibility to extend additional functions.

With more than 20 years of industrial market leadership, Portwell solution ensure retailers are well-positioned to move through the current economy into a successful and profitable future, while giving their customers more information faster and easier than ever before. Portwell's high performance Panel PC in slim, compact style and aesthetic design with various mounting methods can serve a perfect platform as HMI/MMI in POS, KIOSK applications, making lives easier, smarter, more efficient and more interesting.



It's common to see posters or TV monitors in public areas showing latest information like promotional activities in retail stores, commercial or governmental advertisement. What's more is "infotainment", kind of media that combines information and entertainment, not only broadcasting information as posters or TV, but allowing audience to interact with it and enhancing user's experience.

As a result, Portwell adopts sensitive touch screen in systems so that users can quickly choose whatever information and receive instant responses from Portwell's Panel PC. The interaction makes the information searching procedure more fun. In addition to users, information providers can also benefit from Portwell's Panel PC. For example, with tools like database management system, shopkeepers can gather precious data from customers and then effectively increase performance after analyzing. By creating a platform between users and information providers to communicate, Portwell brings values to both parties.

## Digital Signage and Public Infotainment





# Table of Contents

PAGE 1-2 About Portwell  
3-4 System Production Flow  
5-6 Our Philosophy in Panel PC

7-8 Target Market Applications  
9-10 Table of Contents

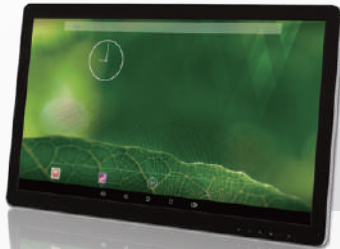

21.5" / 23.6"

## 11 LEAD-Portwell Networking Display

**Stylish, Slim and Projective Capacitive Touch Monitor with Basic Computing Ability Powered by AllWinner® A83T with Fanless Design**

- AllWinner® A83T Octa-Core Cortex™ A7 CPU
- 10-Points Projective Capacitive Multi-Touch
- 1GB DDR3L and 16G eMMC on board
- Android 6.0 Support



21.5" / 23.6"

## 12 LEAD-Portwell Display

**Stylish, Slim and Projective Capacitive Touch Monitor with Fanless Design Suitable for Displaying Information in Various Environment**

- Full HD 1080p Resolution & 10-Points P-CAP Multi-Touch Screen
- Superior Image Quality with High Contrast Ratio
- Fast Response Time without Residual Image
- Solid IP65 Water & Dust Proof Front Bezel



10.4" / 12.1" / 15" / 17" /  
19" / 18.5"

## 13-14 FUDA2 Multi-Touch Panel PC

**Slim and Fan-less Projective Capacitive Touch Panel PC with Wide Temperature and Panel Mount Support Powered by Intel® Bay Trail Quad-core Processor**

- Wide Operating Temperature Support with Fan-less Design
- Projective Capacitive Touch Screen Becomes Popular in Factory Automation Application
- An Ideal HMI for Industrial Market
- Flexible I/O for Industrial Environment



## 15-16 *FUDA2 Single-Touch Panel PC*

Slim and Fan-less 5-wire Resistive Touch Panel PC with **Wide Temperature** Support Powered by Intel® Bay Trail Quad-core Processor

- Wide Operating Temperature Support with Fan-less Design
- An Ideal Panel PC for Semi-outdoor Application
- A More Powerful and Flexible Panel PC
- Effortless Upgrade



10.4" / 12.1" / 15" / 17" / 19" / 18.5"

## 17-18 *FUDA3 Multi-Touch Panel PC*

Slim and Fan-less Projective Capacitive Touch Panel PC with **Wide Temperature** and Panel Mount Support Powered by Intel® Atom x7-E3950 Quad-core Processor

- Wide Operating Temperature Support with Fan-less Design
- Flexible I/O for Industrial Environment
- New Projective Capacitive Touch technology is Stronger and Excellent in Industrial Environment
- An Ideal HMI for Industrial Market



10.4" / 12.1" / 15"

## 19-20 *FUDA3 Single-Touch Panel PC*

Slim and Fan-less 5-wire Resistive Touch Panel PC with **Wide Temperature** Support Powered by Intel® Atom x7-E3950 Quad-core Processor

- High-speed UARTs Support
- Effortless Upgrade
- Name Plate Customization
- A More Powerful and Flexible Panel PC



10.4" / 12.1" / 15"

## 21-22 *COMBO Multi-Touch HMI*

Compact and Projective Capacitive Touch HMI with **Wide Temperature** and Voltage Support Powered by NXP i.MX 6 Series Family

- Panel PC with NXP i.MX 6 Solo/Quad-core Processor
- Wide Operating Temperature Support with Fan-less Design
- Projective Capacitive Multi-Touch Screen
- CAN Bus Connectivity



10.1"

### PAGE Quick Selection Guide

23-24 LEAD

27 FUDA3 Multi-Touch

30 Further Contact

25 FUDA2 Multi-Touch

28 FUDA3 Single-Touch

26 FUDA2 Single-Touch

29 COMBO Multi-Touch

# LEAD-Portwell Networking Display

Stylish, Slim and Projective Capacitive Touch Monitor with Basic Computing Ability  
Powered by AllWinner® A83T with Fanless Design



## Product Introduction

LEAD-Portwell Networking Display or PND has network connection ability with LAN port which adopts Gigabit Ethernet. With Allwinner A83T, PND is equipped with basic computing ability compared to PD. Combining the two features, PND is suitable for those who want to introduce IoT concept into their applications or environments. The OS adopts Android system, which provides users with high flexibility to fulfill their own software requirement. The VGA/HDMI/DP ports enclose the most common signal inputs now. PND provides users with the ability to control the OSD function by Tx/Rx of RS-232 which further enhances the ability of PND and helps customers to easily adopt an IoT scenario.

## No Maze in Airport

Have no idea where you are, what to do next in the flood of flight information? What if the airport information can be personalized just for you? In the future, once arriving the airport, besides the huge information signage, more small panel PCs are waiting for you. By typing or selecting your flight number, the system will let you know where to check in on the map, how long the queue is, expecting time for custom check, location and distance of the gate. Instead of a nightmare to navigate, the airport becomes a personal and pleasant journey.

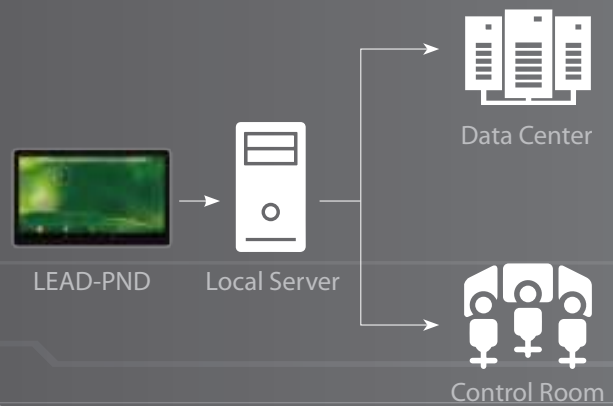

## Key Features

- AllWinner® A83T Octa-Core Cortex™ A7 CPU
- 10-Points Projective Capacitive Multi-Touch
- 1GB DDR3L and 16G eMMC on board
- 2 x 3W speaker
- Optional 1 x VGA or 1 x COM (Tx/Rx only)
- Support Android 6.0

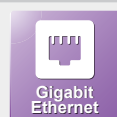
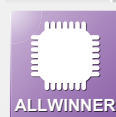
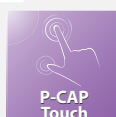
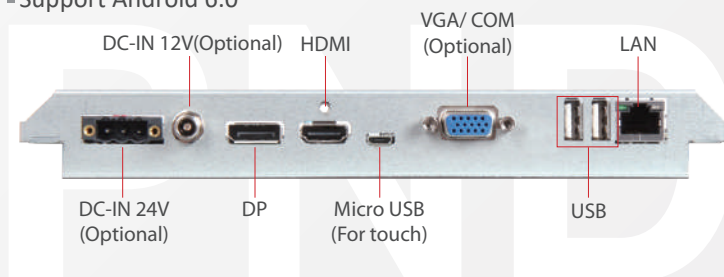

## Ordering Guide

AL6-3276	(R).LEAD-PND-2150-AV. 21.5" 12V AllWinner A83T Black Panel PC with Standard IO.
AL6-3275	(R).LEAD-PND-2150-AC. 21.5" 12V AllWinner A83T Black Panel PC with Tx/Rx IO Replacing VGA.
AL6-3274	(R).LEAD-PND-2150-BV. 21.5" 24V AllWinner A83T Black Panel PC with Standard IO.
AL6-3273	(R).LEAD-PND-2150-BC. 21.5" 24V AllWinner A83T Black Panel PC with Tx/Rx IO Replacing VGA.
AL6-3272	(R).LEAD-PND-2360-AV. 23.6" 12V AllWinner A83T Black Panel PC with Standard IO.
AL6-3271	(R).LEAD-PND-2360-AC. 23.6" 12V AllWinner A83T Black Panel PC with Tx/Rx IO Replacing VGA.
AL6-3270	(R).LEAD-PND-2360-BV. 23.6" 24V AllWinner A83T Black Panel PC with Standard IO.
AL6-3269	(R).LEAD-PND-2360-BC. 23.6" 24V AllWinner A83T Black Panel PC with Tx/Rx IO Replacing VGA.



# LEAD- Portwell Display

Stylish, Slim and Projective Capacitive Touch Monitor with Fanless Design  
Suitable for Displaying Information in Various Environment



## Product Introduction

As the entry product of LEAD series, Portwell Display or PD shares the fantastic stylish appearance and design common to Portwell products. This allows our customers to adopt the PD in the environment that needs to face end users. The full HD and ten-point multi-touch panel can provide the best user experience. The various I/O allows our customers to input information from different sources. This low-cost entry monitor will be your best choice for the occasions that don't need any computing power.

## New Experience in Retail

What would you expect when entering a retail shop? When you arrive at the store, the camera will catch your image and analyze your gender, age and other physical characteristics with the local server. The information will be compared with the data base. According to the result, the system would be able to provide you with customized advertisement, promotion and the location of the merchandise. Afterwards, the system should lead you to the fastest check-out desk to avoid waiting. Or if you don't want to carry all the bags, why not just tell the system to ship them back to your home? Let the friendlier and more customized shopping experience entertain your day.

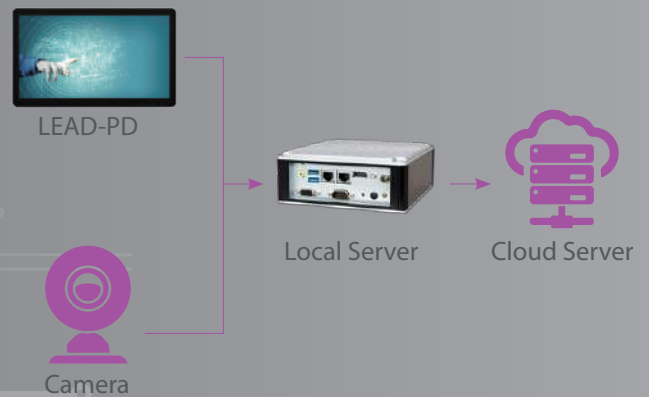

## Key Features

- Full HD 1080p Resolution & 10-Points P-CAP Multi-Touch Screen
- Superior Image Quality with High Contrast Ratio
- Fast Response Time without Residual Image
- Solid IP65 Water & Dust Proof Front Bezel

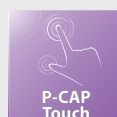
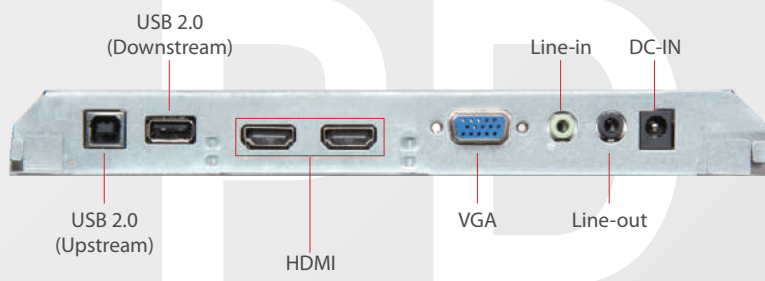

## Ordering Guide

AL8-3081	(R).LEAD-PD-2150. 21.5" FHD Panel Touch Display w/ Touch, Black Housing, Built-in Stand.
AL8-3082	(R).LEAD-PD-2360. 23.6" FHD Panel Touch Display w/ Touch, Black Housing, Built-in Stand.

## 2 Sizes

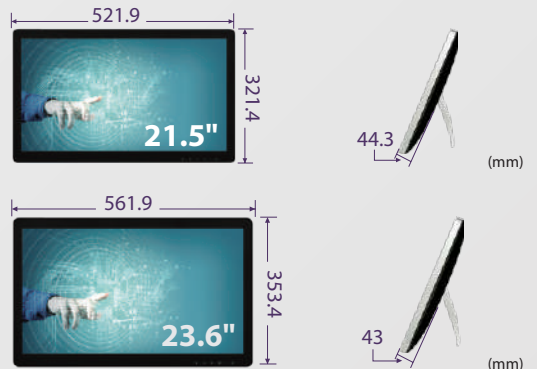

# FUDA2 Multi-Touch Panel PC Series

Slim and Fan-less Projective Capacitive Touch Panel PC with Wide Temperature and Panel Mount Support Powered by Intel® Bay Trail Quad-core Processor

In IPC market, a robust and highly reliable Panel PC system is a must to ensure non-stop and stable operation on production line. By enhancing performance and power efficiency, FUDA2 Series is an ideal HMI solution for factory automation, CNC machine and food and beverage industry.



## Product Introduction

Powered by Intel® Atom® platform, Bay Trail-I SoC processor E3845, which provides extended temperature and high I/O connectivity within 10W thermal design power (TDP), FUDA2 Panel PC is an ideal platform for applications like highly efficient and dedicated image signal processing with secure content delivery and visually appealing HMI thin clients.

Equipped with a high resolution panel and a sleek, responsive, multi-touch screen, FUDA2 Multi-Touch Panel PC comes with an IP65 rated front bezel and true-flat design. This allows the system to be operated in harsh environment. With its refined appearance, rugged mechanical chassis and multiple modular flexibility, FUDA2 Panel PC's application-oriented design provides customers an ideal HMI solution for factory automation applications.

## Wide Operating Temperature Support with Fan-less Design

FUDA2 Panel PC takes advantage of Intel® Atom® E3800 family to operate under extremely hot and cold conditions. Compared to most Panel PC in the market, the operating temperature of FUDA2 Panel PC can be as low as -25°C or up to 70°C in spite of its fan-less design. Moreover, the cable-less structure optimizes the thermal dissipation as well as makes it more durable in rugged environments.



## Flexible I/O for Industrial Environment

FUDA2 Panel PC features all required interfaces for industrial application: 12V ~ 24V DC input, dual LAN, multiple USB ports and RS-232/422/485 selectable in BIOS with auto-flow function. Different I/O extension kits can be chosen to serve different market demands.

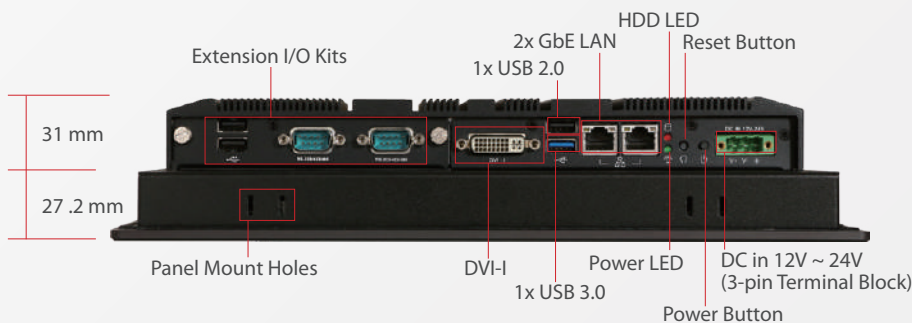

\* The picture of FUDA2-S1221

## I/O Options

### FUDA2 - S1021



2 x RS-232 / 422 / 485  
Option 0



1 x Line-out  
1 x RS-232 / 422 / 485  
Option 1

### FUDA2-S12/15/17/1921 & FUDA2-S1820



2 x USB 2.0  
2 x RS-232 / 422 / 485  
Option 0



1 x RS-232  
2 x RS-232 / 422 / 485  
Option 1



2 x USB 2.0, 1 x Line-out  
1 x RS-232 / 422 / 485  
Option 2



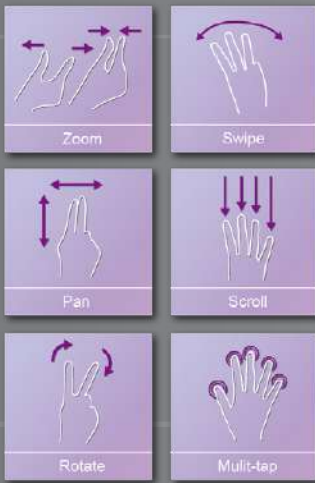

Front  
IP65



### Projective Capacitive Touch Panel PC Becomes Popular in Factory Automation Application

Thanks to its robustness and easy operation, Panel PC with projective capacitive touch screen becomes a popular solution in the factory automation industry. With the latest touch screen technology, FUDA2 Multi-Touch Panel PC Series is responsive even when thick industrial gloves are worn and supports palm rejection. Moisture, contaminant, and cutting oil are common in an industrial environment, so it is important these materials don't cause any false actions to the machine. Last but not least, its excellent noise immunity makes it suitable in industrial application.

### An Ideal HMI for Industrial Market

FUDA2 Multi-Touch Panel PC targets to apply in industrial environment. Designed to comply with UL 61010-2-201, which specifically addresses safety requirements and related verification tests for industrial control equipment, as well as the EMC directives for both industrial environment and information technology equipment like EN 55032, BS EN 55032, EN 55035, BS EN 55035, EN 61000-6-2, BS EN 61000-6-2, EN 61000-6-4, BS EN 61006-4, FUDA2 Multi-Touch Panel PC has proved itself an ideal HMI for industrial market by not only passing a variety of thorough and rigorous testing but also being verified by independent certified lab agent.



### Ordering Guide

AL6-3222	(R).ATO. FUDA2-S1021-0000-00.10.4" Intel Bay Trail E3845 Projective Capacitive Touch Panel PC
AL6-3226	(R).ATO. FUDA2-S1221-0000-00.12.1" Intel Bay Trail E3845 Projective Capacitive Touch Panel PC
AL6-3227	(R).ATO. FUDA2-S1521-0000-00.15" Intel Bay Trail E3845 Projective Capacitive Touch Panel PC
AL6-3223	(R).ATO. FUDA2-S1721-0000-00.17" Intel Bay Trail E3845 Projective Capacitive Touch Panel PC
AL6-3209	(R).ATO. FUDA2-S1921-0000-00.19" Intel Bay Trail E3845 Projective Capacitive Touch Panel PC
AL6-3200	(R).ATO. FUDA2-S1820-0000-02.18.5" Intel Bay Trail E3845 Projective Capacitive Touch Panel PC
AL6-3242	(R).FUDA2-S1521-0000-00.15" Intel Bay Trail E3845 Projective Capacitive Touch Panel PC with Black Aluminum Bezel and Black Chassis. 4G RAM. 32G SSD. Panel mount. Extension 2*COM/2*USB



# FUDA2 Single-Touch Panel PC Series

Slim and Fan-less 5-wire Resistive Touch Panel PC with Wide Temperature Support  
Powered by Intel® Bay Trail Quad-core Processor

In IPC market, a robust and highly reliable Panel PC system is a must to ensure non-stop and stable operation on production line. By enhancing performance and power efficiency, FUDA2 Series is an ideal HMI in factory automation, food and beverage industry, vending machine or semi-outdoor environments.

## Product Introduction

FUDA2 Panel PC is the next generation of Portwell's standard Panel PC product line. Its ascendant, FUDA Panel PC, has been widely proven and adopted by industrial markets like application in factory automation and transportation. Keeping the successful designing and marketing experience in mind, FUDA2 Panel PC aims at serving IPC customers with much more powerful HMI solutions which provide high performance and low power consumption. Powered by Intel® Atom® platform, Bay Trail-I SoC processor E3845, which provides extended temperature and high I/O connectivity within 10W thermal design power (TDP), FUDA2 Panel PC is an ideal platform for applications like highly efficient and dedicated image signal processing with secure content delivery and visually appealing HMI thin clients.



## Wide Operating Temperature Support with Fan-less Design

FUDA2 Panel PC takes advantage of Intel® Atom® E3800 family to operate under extremely hot and cold conditions. Compared to most Panel PC in the market, the operating temperature of FUDA2 Panel PC can be as low as -25°C or up to 70°C in spite of its fan-less design. Moreover, the cable-less structure optimizes the thermal dissipation as well as makes it more durable in rugged environments.

## Effortless Upgrade

FUDA2 Single-Touch Panel PC Series has been designed to be 100% mechanically compatible with the previous FUDA Panel PC – offering a smart, economical and easy replacement or upgrade solution. Customers can enjoy the identical mechanical design to give a direct upgrade to Intel's latest platform without any need to modify existing machine cabinets or mounting kits.

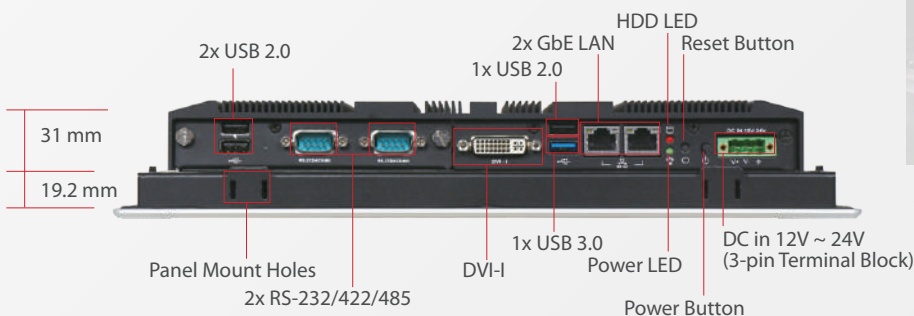

\* The picture of FUDA2-S1011







### ■ An Ideal Panel PC for Semi-outdoor Application

Facilitated with an ambient light sensor, FUDA2 Single-Touch Panel PC Series is capable of automatically adjust panel brightness by sensing light intensity in the surroundings, which allows it to be more user friendly by optimizing the display's visibility in semi-outdoor environments. Other than providing comfortable viewing experience, this function also benefits FUDA2 Panel PC by lowering the power consumption and extending the lifetime of LED display.

### ■ A More Powerful and Flexible Panel PC

By adopting the latest Intel® Atom® Bay Trail platform, FUDA2 Panel PC can achieve up to 3x the peak performance and 5x the power efficiency of the previous FUDA Panel PC; especially the visual processing capabilities are improved to enable faster media conversation as well as enhanced HD video transcoding. In addition, more functions are made available; for example, multiple storage including 2.5" HDD/SSD, CF and SD card, WiFi or 3G solutions; USB 3.0 is also adopted. Besides, one PCIe x1 slot and internal 2W speaker is reserved for project use.

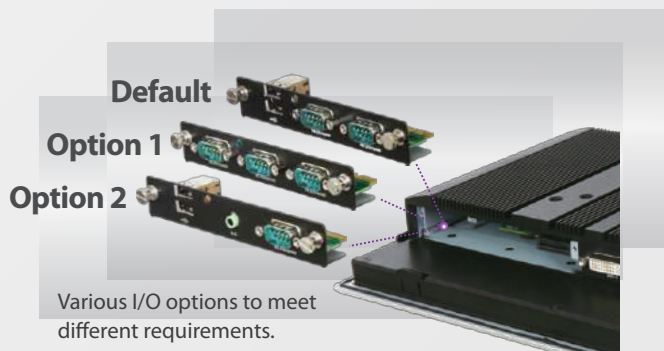

### Ordering Guide

AL6-3192	(R)ATO.FUDA2-S1011-AP1000.10.4" Bay Trail E3845 Panel PC with Aluminum Bezel and PW Overlay
AL6-3191	(R)ATO.FUDA2-S1211-AP1000.12.1" Bay Trail E3845 Panel PC with Aluminum Bezel and PW Overlay
AL6-3190	(R)ATO.FUDA2-S1511-AP1000.15" Bay Trail E3845 Panel PC with Aluminum Bezel and PW Overlay
AL6-3189	(R)ATO.FUDA2-S1711-AP1000.17" Bay Trail E3845 Panel PC with Aluminum Bezel and PW Overlay
AL6-3188	(R)ATO.FUDA2-S1911-AP1000.19" Bay Trail E3845 Panel PC with Aluminum Bezel and PW Overlay
AL6-3208	(R)ATO.FUDA2-S1830-0000-02.18.5" Intel Bay Trail E3845 Flat 5W Resistive Touch Panel PC
AL6-3241	(R).FUDA2-S1511-AP1000. 15" Intel Bay Trail E3845 Panel PC with Aluminum Bezel and PW Overlay. 4G RAM. 32G SSD. Panel mount. Extension 2*COM/2*USB





# FUDA3 Multi-Touch Panel PC Series

Slim and Fan-less Projective Capacitive Touch Panel PC with Wide Temperature Support  
Powered by Intel® Atom E3900 Family Processors

In IPC market, a robust and highly reliable Panel PC system is a must to ensure non-stop and stable operation on production line. By enhancing performance and power efficiency, FUDA3 Series is an ideal HMI in factory automation, vending machine, Textile machine and harsh dirty industry environments.



## Product Introduction

Powered by Intel® Atom® x7-E3950 which provides extended temperature and flexible I/O connectivity within 12 watt thermal design power (TDP), FUDA3 Series Panel PC is an ideal platform for applications like highly efficient and dedicated image signal processing with secure content delivery and visually appealing HMI thin clients. Equipped with a high resolution panel and a sleek, responsive, multi-touch screen, FUDA3 Multi-Touch Panel PC comes with an IP65 rated front bezel and true-flat design. This allows the system to be operated in harsh environment. With its refined appearance, rugged mechanical chassis and multiple modular flexibility, FUDA3 Panel PC's application-oriented design provides customers an ideal HMI solution for factory automation applications.

## Wide Operating Temperature Support with Fan-less Design

FUDA3 Panel PC takes advantage of Intel® Atom® E3900 family to operate under extremely hot and cold conditions. Compared to most Panel PC in the market, the operating temperature of FUDA3 Panel PC can be as low as -25°C or up to 60°C in spite of its fan-less design. Moreover, the cableless structure optimizes the thermal dissipation as well as makes it more durable in rugged environments.



## Flexible I/O for Industrial Environment

FUDA3 Panel PC features all required interfaces for industrial application: 12V ~ 24V DC input, dual LAN, HDMI, USB 3.0, USB 2.0, USB OTG ports and RS-232/422/485 selectable in BIOS with auto-flow function. Different I/O extension kits can be chosen to serve different market demands.

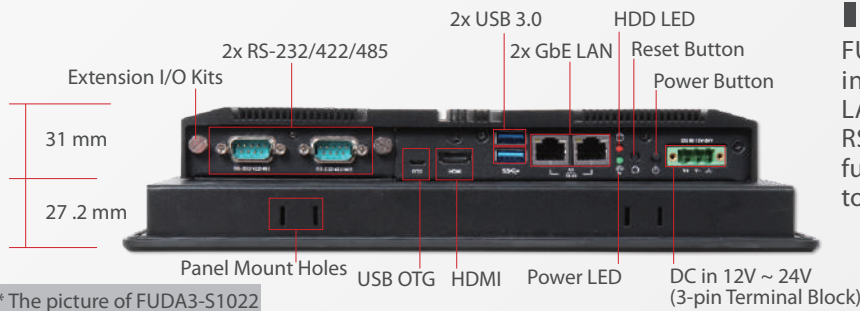

\* The picture of FUDA3-S1022

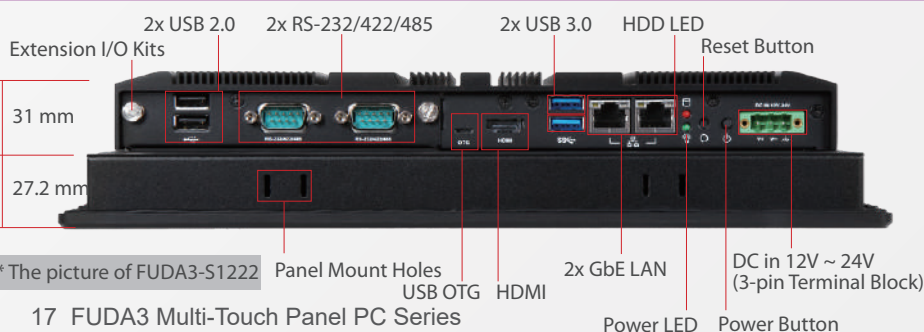

\* The picture of FUDA3-S1222

## I/O Options

### FUDA3 - S1022



2 x RS-232 / 422 / 485  
Option 0

### FUDA3 - S1222 / S1522



2 x USB 2.0  
2 x RS-232 / 422 / 485  
Option 0



1 x RS-232  
2 x RS-232 / 422 / 485  
Option 1



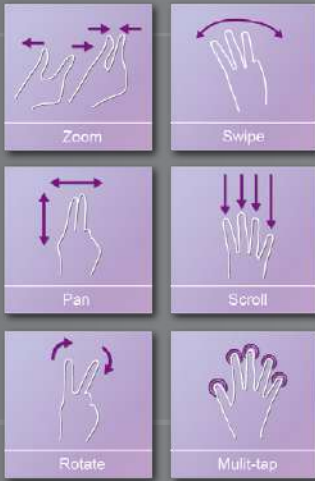

60°C / -25°C  
 Front IP65



### ■ New Projective Capacitive Touch technology is Stronger and Excellent in Industrial Environment

New touch technologies, such as excellent noise immunity for any Industrial environment (CS 10Vrm), excellent radiated susceptibility support up to 50V/m, premium water resistance performance and heavy glove support, are implemented on FUDA3 projective capacitive multi-touch screen series Panel PC. It can solve the problem that projective capacitive multi-touch screens do not operate effectively within an industrial input voltage noise interference environment. We believe that "adopting our FUDA3 Series Panel PC is the obvious choice to adopt in industrial HMI market."

### ■ An Ideal HMI for Industrial Market

FUDA3 P-CAP Touch Panel PC targets to apply in industrial environment. Designed to comply with heavy industry, which specifically addresses safety requirements and related verification tests for industrial control equipment, as well as the EMC directives for both industrial environment and information technology equipment like EN 55032, BS EN 55032, EN 55035, BS EN 550535, EN 61000-6-2, BS EN 61000-6-2, EN 61000-6-4, BS EN 61000-6-4, FUDA3 P-CAP Touch Panel PC has proved itself an ideal HMI for industrial market by not only passing a variety of thorough and rigorous testing but also being verified by independent certified lab agent.



### Ordering Guide

AL6-3292	(R).ATO. FUDA3-S1022-0000-00.10.4" Intel® Apollo Lakel E3950 Projective Capacitive Touch Panel PC
AL6-3296	(R).ATO. FUDA3-S1222-0000-00.12.1" Intel® Apollo Lakel E3950 Projective Capacitive Touch Panel PC
AL6-3291	(R).ATO. FUDA3-S1522-0000-00. 15" Intel® Apollo Lakel E3950 Projective Capacitive Touch Panel PC

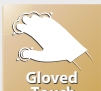



# FUDA3 Single-Touch Panel PC Series

Slim and Fan-less five wire Resistive Touch Panel PC with Wide Temperature Support  
Powered by Intel® Atom E3900 Family Processors

In IPC market, a robust and highly reliable Panel PC system is a must to ensure non-stop and stable operation on production line. By enhancing performance and power efficiency, FUDA3 Series is an ideal HMI in factory automation, vending machine, Textile machine and harsh dirty industry environments.

## Product Introduction

FUDA3 Panel PC is the next generation of Portwell's standard Panel PC product line. Its ascendant, FUDA and FDU2 Panel PC, has been widely proven and adopted by industrial markets like application in factory automation and machine automation. Keeping the successful designing and marketing experience in mind, FUDA3 Panel PC aims at serving IPC customers with much more powerful HMI solutions which provide high performance and low power consumption. Powered by Intel® Atom® x7-E3950, which provides extended temperature and flexible I/O connectivity within 12 watt thermal design power (TDP), FUDA3 Panel PC is an ideal platform for applications like highly efficient and dedicated image signal processing with secure content delivery and visually appealing HMI thin clients.



## High-speed UARTs Support

As we all know, UART port such as **RS-232/422/485** is very important I/O to communicate between device and device at factory. FUDA3 Panel PC adopt new Super I/O chip to make UART ports support high-speed baud rate from 115.2K up to maximum 921.6K under Windows 10. The advantage can solve I/O communication slowly problem in factory automation environment.

## Effortless Upgrade

FUDA3 Single-Touch Panel PC Series has been designed to be 100% mechanically compatible with the previous FUDA/FUDA2 Panel PC – offering a smart, economical and easy replacement or upgrade solution. Customers can enjoy the identical mechanical design to give a direct upgrade to Intel's latest platform without any need to modify existing machine any need to modify existing machine cabinets or mounting kits.

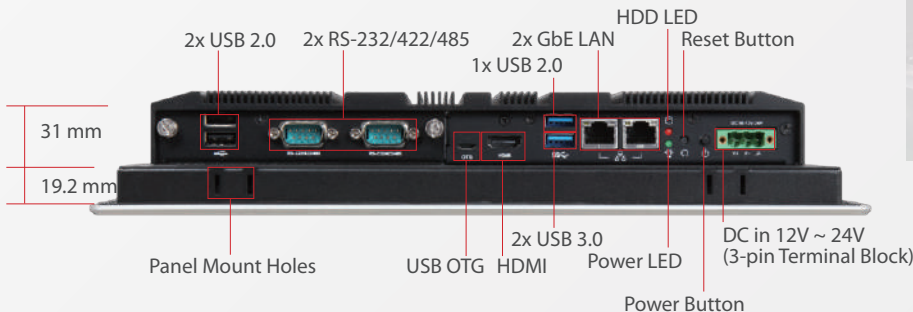

\* The picture of FUDA3-S1012





### ■ Name Plate Customization

FUDA3 5-wire Resistive Panel PC offer a name plate customization service with small MOQ for customer to design their logo, color and style. It is ideal solution for customer to create itself unique product quickly.

### ■ A More Powerful and Flexible Panel PC

By adopting the latest Intel® Atom® x7-3950, FUDA3 series Panel PC can achieve up to 2x the power efficiency of the previous FUDA2 Panel PC; especially the visual processing capabilities are improved to enable faster media conversation as well as enhanced HD video transcoding. In addition, more functions are made available; for example, multiple storage including 2.5" HDD/SSD and Mini-mSATA ; WiFi or LTE solutions; USB 3.0 is also adopted.



Various I/O options to meet different requirements.

### Ordering Guide

AL6-3290	(R).ATO. FUDA3-S1012-0000-00.10.4" Intel® Apollo Lake E3950 5-wire Resistvie Touch Panel PC with PW Overlay
AL6-3295	(R).ATO. FUDA3-S1212-0000-00.12.1" Intel® Apollo Lake E3950 5-wire Resistvie Touch Panel PC with PW Overlay
AL6-3289	(R).ATO. FUDA3-S1522-0000-00. 15" Intel® Apollo Lake E3950 5-wire Resistvie Touch Panel PC with PW Overlay



# COMBO Multi-Touch HMI Series

Compact and Projective Capacitive Touch HMI with Wide Temperature and Voltage Support Powered by NXP i.MX 6 Series Family

In IPC market, a robust and highly reliable Panel PC system is a must to ensure non-stop and stable operation on production line. Featuring cost effective and power efficiency, COMBO Series is an ideal HMI in factory automation, food and beverage industry, data collecting equipment environments.

## Product Introduction

yocto  
PROJECT



COMBO Series HMI is a new era and innovation of Portwell's standard HMI product line. Powered by NXP i.MX6 processor, the cost effective and power efficient HMI comes with one Gigabit Ethernet, two USB 2.0 hosts, one OTG, one HDMI input port, one HDMI output port, one serial port, one CAN port, a wide range DC input from DC 12V to 24V and an optional Wi-Fi/3G/4G feature. Besides, it is equipped with 512MB or 2GB DDR3 memory down and 8GB eMMC, which targets to support mission-critical industrial applications.

COMBO Series HMI can boot from the onboard eMMC or SD card to Yocto Linux 4.1.15 kernel version or Android 6.0 operating systems via U-Boot boot loader, specially customized to take full advantage of the i.MX6 CPU 3D graphics acceleration capabilities. To sum up, COMBO Series HMI is a ready platform for all kind of industrial applications, including factory automation, machine automation, data collecting and energy-saving control systems.

## HMI with NXP i.MX 6 Solo/Quad-core Processor

The i.MX 6 series processors unleash a scalable multi-core platform that includes single-, dual- and quad-core families based on the ARM® Cortex™ A9 architecture for next generation industrial applications. By combining the power-efficient processing capabilities with bleeding edge 3D and 2D graphics, as well as high-definition video, the i.MX 6 series provides a new level of multimedia performance to enable an unbounded next generation user experience. The unprecedented levels of performance and power efficiency making it an ideal solution for designs requiring high performance in low power or thermally constrained cost-sensitive devices.



NXP freescale™  
Enabled

## CAN Bus Connectivity

COMBO Series HMI features CAN Bus specification version 2.0B, which supports both standard and extended message frames communication, making it a suitable equipment for applications such as cars, trucks, tractors, trains, agricultural machinery, textile machinery, etc. With a high degree of reliability and stability, CAN Bus is also widely used in industrial control.

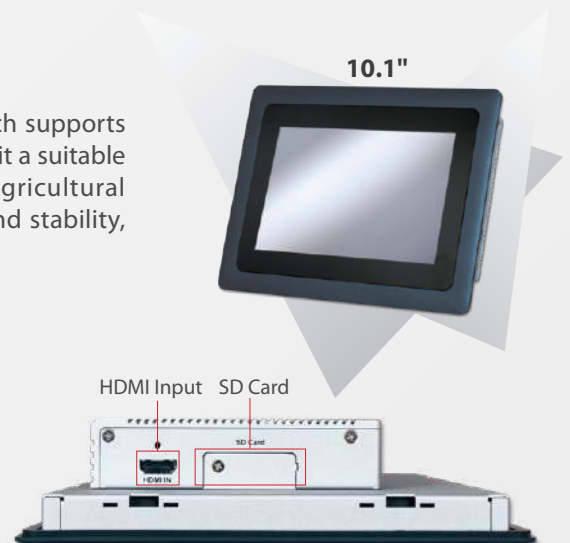
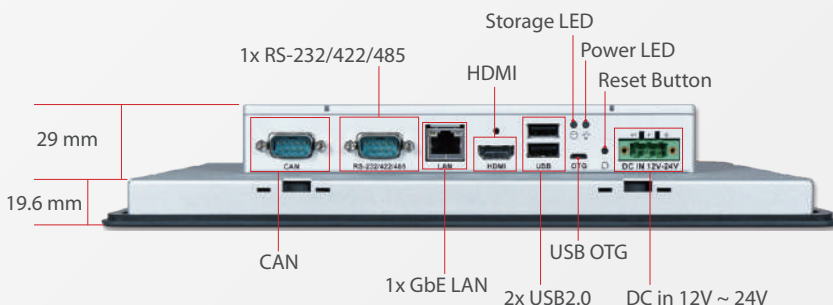

\* The picture of COMBO-S1020



60°C  
-20°C



## Wide Operating Temperature Support with Fan-less Design

COMBO Series HMI takes advantage of NXP i.MX6 family to operate under extremely hot and cold conditions. Compared to most HMI in the market, the operating temperature of COMBO Series HMI can be as low as -20°C or up to 60°C in spite of its fan-less design. Moreover, the cable-less structure optimizes the thermal dissipation as well as makes it more durable in rugged environments.

## Projective Capacitive Multi-Touch Screen

By adopting antiscratch surface with 7H hardness protection, high touch durability and long-term stability are built-in features of COMBO Series HMI. 10-points multi-touch supports a full set of gestures such as zooming in/out, panning, or rotating, giving users a whole new way to control and interact with what's on the screen even with surgical gloves or thin cotton gloves.

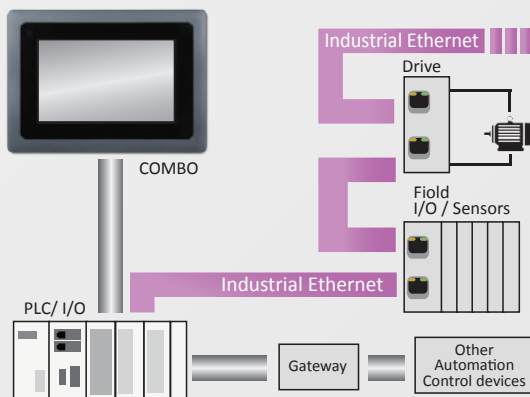
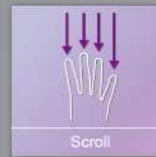
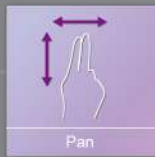
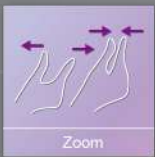

## Act multi-mission as PC / Monitor

COMBO Series HMI can not only support dual display output via an additional HDMI output port, but also support monitor function via one HDMI input port. It can be an ideal PIP (picture in picture) solution to integrate external video signal and compute on COMBO 10.1" HMI by itself.

## Ordering Guide

AL6-3224	(R).ATO.COMBO-S1020-Solo-512-8G. 10.1" i.MX6 P-CAP HMI
AL6-3236	(R).ATO.COMBO-S1020-Quad-2G-8G. 10.1" i.MX6 P-CAP HMI

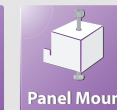
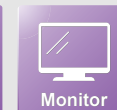
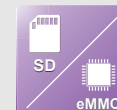
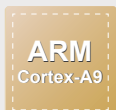

# LEAD Quick Selection Guide

LEAD Series-PD / PND 21.5"/23.6"

Model Name	LEAD-PD-2150	LEAD-PD-2360	LEAD-PND-2150-AC	LEAD-PND-2360-AC	LEAD-PND-2150-BC	LEAD-PND-2360-BC
<b>Display</b>						
LCD Size	21.5"	23.6"	21.5"	23.6"	21.5"	23.6"
Resolution	FHD 1920 x 1080	FHD 1920 x 1080	FHD 1920 x 1080	FHD 1920 x 1080	FHD 1920 x 1080	FHD 1920 x 1080
Brightness	250 cd/m <sup>2</sup>	250 cd/m <sup>2</sup>	250 cd/m <sup>2</sup>	250 cd/m <sup>2</sup>	250 cd/m <sup>2</sup>	250 cd/m <sup>2</sup>
Contrast Ratio	1000: 1	1000: 1	1000: 1	1000: 1	1000: 1	1000: 1
Backlight	LED type	LED type	LED type	LED type	LED type	LED type
Panel Type	TN	TN	TN	TN	TN	TN
Viewing Angle (H/V)	170° (H) / 160° (V)	170° (H) / 160° (V)	170° (H) / 160° (V)	170° (H) / 160° (V)	170° (H) / 160° (V)	170° (H) / 160° (V)
Touch Screen	Projected Capacitive Multi-Touch		Projected Capacitive Multi-Touch		Projected Capacitive Multi-Touch	
<b>System</b>						
SoC	N/A, Monitor Only		AllWinner A83T Octa-Core Cortex™ A7 CPU		AllWinner A83T Octa-Core Cortex™ A7 CPU	
Memory			1GB DDR3L on board		1GB DDR3L on board	
BIOS			N/A		N/A	
Graphics			PowerVR SGX544 GPU		PowerVR SGX544 GPU	
LVDS			Dual Channel 24-bit		Dual Channel 24-bit	
LAN Chip			Realtek® RTL8211E		Realtek® RTL8211E	
Audio Codec			AllWinner AXP813		AllWinner AXP813	
Storage Device			16G eMMC on board		16G eMMC on board	
OS			Android 6.0		Android 6.0	
<b>I/O Interface</b>						
Serial Port	N/A		1 x Tx/Rx for OSD function		1 x Tx/Rx for OSD function	
Display	Input: 2 x HDMI, 1 x VGA		Input: 1 x HDMI, 1 x DP		Input: 1 x HDMI, 1 x DP	
USB	Upstream: 1 x USB 2.0 Type B Downstream: 1 x USB 2.0 Type A		2 x USB 2.0 1 x Micro USB for Touch only		2 x USB 2.0 1 x Micro USB for Touch only	
Ethernet	N/A		1 x Gigabit Ethernet		1 x Gigabit Ethernet	
Audio	2 x 2W Speaker, 1 x Line out, 1 x Line in		2 x 3W Speaker		2 x 3W Speaker	
OSD Key	Power / Menu / Right / Left / Auto		Power / Menu / Right / Left / Auto		Power / Menu / Right / Left / Auto	
Expansion	N/A		N/A		N/A	
<b>Mechanical</b>						
Dimension(mm) (WxDxH)	521.9 x 321.4 x 44.3 mm	561.9 x 353.4 x 43 mm	521.9 x 321.4 x 44.3 mm	561.9 x 353.4 x 43 mm	521.9 x 321.4 x 44.3 mm	561.9 x 353.4 x 43 mm
Mounting (mm)	Standalone; VESA Mount 75 x 75		Standalone; VESA Mount 75 x 75		Standalone; VESA Mount 75 x 75	
Weight (Kg)(N)	4.1 Kg	4.4Kg	4.1 Kg	4.4Kg	4.1 Kg	4.4Kg
Weight (Kg)(G)	5.8 Kg	6.3 Kg	5.8 Kg	6.3 Kg	5.8 Kg	6.3 Kg
<b>Power</b>						
Power Input	DC 20V via DC Jack		DC 12V via DC Jack		DC 24V via 3-pin terminal block connector	
Power Supply	45W AC-DC Adapter, Power Cord		40W AC-DC Adapter		60W AC-DC Adapter	
<b>Environmental</b>						
OP / Storage Temp	0~40°C / -25~55°C(20~90% non-condensing)		0~50°C / -20~60°C(20~90% non-condensing)		0~50°C / -20~60°C(20~90% non-condensing)	
Vibration	N/A		1G , Power on ; 10~500Hz, IEC 60068-2-6			
Shock	N/A		15G peak acceleration, 11 ms (Power on condition), IEC 60068-2-27			
Drop	N/A		Packaged with Carton 96.5cm (1-Corner, 3-Axis, 6-Face), ISTA 2A Standard			
IP Protection	IP65 (Front) / IP20 (Rear) (IEC 60529 Edition 2.1 Standard)		IP65 (Front) / IP20 (Rear) (IEC 60529 Edition 2.1 Standard)		IP65 (Front) / IP20 (Rear) (IEC 60529 Edition 2.1 Standard)	
Certificate	CE/FCC Class B,BSMI		CE/FCC Class A, VCCI Conformity		CE/FCC Class A, VCCI Conformity	



# LEAD Quick Selection Guide

LEAD Series-PD / PND 21.5"/23.6"

Model Name	LEAD-PND-2150-AV	LEAD-PND-2360-AV	LEAD-PND-2150-BV	LEAD-PND-2360-BV
<b>Display</b>				
LCD Size	21.5"	23.6"	21.5"	23.6"
Resolution	FHD 1920 x 1080	FHD 1920 x 1080	FHD 1920 x 1080	FHD 1920 x 1080
Brightness	250 cd/m <sup>2</sup>	250 cd/m <sup>2</sup>	250 cd/m <sup>2</sup>	250 cd/m <sup>2</sup>
Contrast Ratio	1000: 1	1000: 1	1000: 1	1000: 1
Backlight	LED type	LED type	LED type	LED type
Panel Type	TN	TN	TN	TN
Viewing Angle (H/V)	170° (H) / 160° (V)	170° (H) / 160° (V)	170° (H) / 160° (V)	170° (H) / 160° (V)
Touch Screen	Projected Capacitive Multi-Touch		Projected Capacitive Multi-Touch	
<b>System</b>				
SoC	AllWinner A83T Octa-Core Cortex™ A7 CPU		AllWinner A83T Octa-Core Cortex™ A7 CPU	
Memory	1GB DDR3L on board		1GB DDR3L on board	
BIOS	N/A		N/A	
Graphics	PowerVR SGX544 GPU		PowerVR SGX544 GPU	
LVDS	Dual Channel 24-bit		Dual Channel 24-bit	
LAN Chip	Realtek® RTL8211E		Realtek® RTL8211E	
Audio Codec	AllWinner AXP813		AllWinner AXP813	
Storage Device	16G eMMC on board		16G eMMC on board	
OS	Android 6.0		Android 6.0	
<b>I/O Interface</b>				
Serial Port	N/A		N/A	
Display	Input: 1 x HDMI, 1 x DP, 1 x VGA		Input: 1 x HDMI, 1 x DP, 1 x VGA	
USB	2 x USB 2.0 1 x Micro USB for Touch only		2 x USB 2.0 1 x Micro USB for Touch only	
Ethernet	1 x Gigabit Ethernet		1 x Gigabit Ethernet	
Audio	2 x 3W Speaker		2 x 3W Speaker	
OSD Key	Power / Menu / Right / Left / Auto		Power / Menu / Right / Left / Auto	
Expansion	N/A		N/A	
<b>Mechanical</b>				
Dimension(mm) (WxDxH)	521.9 x 321.4 x 44.3 mm	561.9 x 353.4 x 43 mm	521.9 x 321.4 x 44.3 mm	561.9 x 353.4 x 43 mm
Mounting (mm)	Standalone; VESA Mount 75 x 75		Standalone; VESA Mount 75 x 75	
Weight (Kg)(N)	4.1 Kg	4.4Kg	4.1 Kg	4.4Kg
Weight (Kg)(G)	5.8 Kg	6.3 Kg	5.8 Kg	6.3 Kg
<b>Power</b>				
Power Input	DC 12V via DC Jack		DC 24V via 3-pin terminal block connector	
Power Supply	40W AC-DC Adapter		60W AC-DC Adapter	
<b>Environmental</b>				
OP /Storage Temp	0~50°C / -20~60°C(20~90% non-condensing)		0~50°C / -20~60°C(20~90% non-condensing)	
Vibration	1.0G , Power on ; 10~500Hz, IEC 60068-2-6			
Shock	15G peak acceleration, 11 ms (Power on condition), IEC 60068-2-27			
Drop	Packaged with Carton 96.5cm (1-Corner, 3-Axis, 6-Face), ISTA 2A Standard			
IP Protection	IP65 (Front) / IP20 (Rear) (IEC 60529 Edition 2.1 Standard)		IP65 (Front) / IP20 (Rear) (IEC 60529 Edition 2.1 Standard)	
Certificate	CE/FCC Class A, VCCI Conformity		CE/FCC Class A, VCCI Conformity	

# FUDA2 Quick Selection Guide

FUDA2 Multi-Touch 10.4" / 12.1" / 15" / 17" / 19" / 18.5"

Model Name	FUDA2-S1021	FUDA2-S1221	FUDA2-S1521	FUDA2-S1721	FUDA2-S1921	FUDA2-S1820
<b>Display</b>						
LCD Size	10.4"	12.1"	15"	17"	19"	18.5" (16:9)
Resolution	XGA 1024 x 768	XGA 1024 x 768	XGA 1024 x 768	SXGA 1280 x 1024	SXGA 1280 x 1024	1366 x 768
Brightness	450 cd/m <sup>2</sup>	600 cd/m <sup>2</sup>	450 cd/m <sup>2</sup>	350 cd/m <sup>2</sup>	350 cd/m <sup>2</sup>	350 cd/m <sup>2</sup>
Contrast Ratio	3000:1	700:1	700:1	1000:1	1000:1	1000:1
Backlight	LED type	LED type	LED type	LED type	LED type	LED type
Touch Screen	Projected Capacitive Multi-Touch (10 points)					(2 points)
<b>System</b>						
SoC	Intel® Atom® Quad-core E3845 (1.91 GHz)					
Memory	DDR3L 1333/1600 SO-DIMM up to 8GB					
BIOS	AMI					
Graphics	Intel® Gen 7 Graphics					
LVDS	Single/Dual Channel 24-bit					
LAN Chipset	Dual Intel® 1210T Gigabit Ethernet (Support Jumbo Frame)					
Audio	Realtek® High Definition Audio Codec					
Watchdog Timer	Programmable 1 ~ 255 sec					
Storage Device	1 x 2.5" SATA HDD/ SSD, 1 x Compact Flash II up to 64GB, 1 x SD card					
OS	Windows 7/ Windows 8.1/ Windows 10/ Linux™					
<b>I/O Interface</b>						
Series Port	2 x RS-232/422/485 (Expansion: Option 0)					
Display	1x DVI-H					
USB	1 x USB 2.0, 1 x USB 3.0, 2 x USB 2.0 (Expansion: Option 0)					
Ethernet	2 x Gigabit Ethernet					
Others	1 x SMA Antenna hole for WIFI/3G Solution					
Expansion	1 x Half mPCIe socket 1 x RS-232/422/485, 1 x Line-out (Option 1) 1 x Line-out, 2 x USB 2.0 (Option 2)		1 x Half-size Mini-PCIe socket 2 x RS-232/422/485, 1 x RS-232 (Expansion: Option 1) 1 x RS-232/422/485, 1 x Line-out, 2 x USB 2.0 (Expansion: Option 2)			
<b>Mechanical</b>						
Dimension(mm)(WxDxH)	282 x 238 x 57.3 mm	305 x 260 x 58.2 mm	384 x 310 x 56.6 mm	437 x 375 x 63.2 mm	480 x 400 x 60.4 mm	467 x 293 x 63.4 mm
Mounting (mm)	VESA Mount 75 x 75, 100 x 100; Panel Mount					
Weight (Kg)(N)	3.5 Kg	3.9 Kg	5.1 Kg	6.5 Kg	7.6 Kg	7 Kg
Weight (Kg)(G)	5.8 Kg	6 Kg	7.8 Kg	9.8 Kg	11.5 Kg	10.3 Kg
<b>Power</b>						
Power Supply	DC 12V ~ 24V input with 3-pin terminal block connector					
Consumption (Max)	41W(12V); 40W(24V)	34W(12V); 34W(24V)	39W(12V); 38W(24V)	47W(12V); 46W(24V)	40W(12V); 42W(24V)	43W(12V); 45W(24V)
Consumption (Min)	15W(12V); 16W(24V)	13W(12V); 14W(24V)	16W(12V); 17W(24V)	14W(12V); 15W(24V)	20W(12V); 21W(24V)	23W(12V); 23W(24V)
<b>Environmental</b>						
OP /Storage Temp	-25°C ~ 70°C / -40°C ~ 85°C (20°C ~ 90% non-condensing)					0°C ~ 50°C / -20°C ~ 60°C
Vibration	1.0G(SD/CF/SSD) and 0.5G(HDD) , Power on & 2.16G, Packaged; 5~500Hz, IEC 60068-2-6					
Shock	15G peak acceleration, 11 ms (Power on condition), IEC 60068-2-27					
Drop	Packaged with Carton 96.5cm (1-Corner, 3-Axis, 6-Face), ISTA 2A Standard					
IP Protection	IP65 (Front) / IP20 (Rear), IEC 60529 Edition 2.1 Standard					
Certificate	CE/FCC Class A, UKCA, EN 62368-1, EN 61000-6-2 , EN 61000-6-4 , UL 61010-2-201 (FUDA2-S1921 only)					

## Cut out Dimension

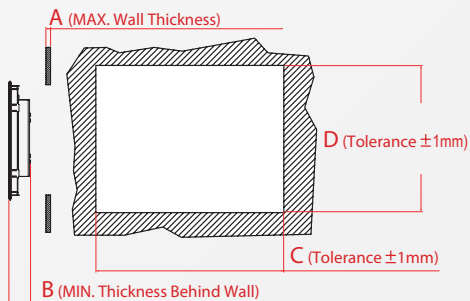

## FUDA2 Multi-Touch

	A (mm)	B (mm)	C (mm)	D (mm)	Mounting Kits (pcs)
FUDA2-S1021	<10	52.5	265	222	X 8
FUDA2-S1221	<10	52.4	289	244	X 8
FUDA2-S1521	<7	50.6	367	293	X 14
FUDA2-S1721	<8	57.4	420	358	X 16
FUDA2-S1921	<7.8	52.6	463	383	X 20
FUDA2-S1820	< 10.7	58.1	452	277	X 16



# FUDA2 Quick Selection Guide

FUDA2 Single-Touch 10.4" / 12.1" / 15" / 17" / 19" / 18.5"

Model Name	FUDA2-S1011	FUDA2-S1211	FUDA2-S1511	FUDA2-S1711	FUDA2-S1911	FUDA2-S1830
<b>Display</b>						
LCD Size	10.4"	12.1"	15"	17"	19"	18.5" (16:9)
Resolution	XGA 1024 x 768	XGA 1024 x 768	XGA 1024 x 768	SXGA 1280 x 1024	SXGA 1280 x 1024	1366 x 768
Brightness	450 cd/m <sup>2</sup>	500 cd/m <sup>2</sup>	450 cd/m <sup>2</sup>	350 cd/m <sup>2</sup>	350 cd/m <sup>2</sup>	350 cd/m <sup>2</sup>
Contrast Ratio	3000:1	700:1	700:1	1000:1	1000:1	1000:1
Backlight	LED type	LED type	LED type	LED type	LED type	LED type
Touch Screen	5-Wire Resistive Single Touch					F5WR Single Touch
<b>System</b>						
SoC	Intel® Atom® Quad-core E3845 (1.91 GHz)					
Memory	DDR3L 1333/1600 SO-DIMM up to 8GB					
BIOS	AMI					
Graphics	Intel® Gen 7 Graphics					
LVDS	Single/ Dual Channel 24-bit					
LAN Chipset	Dual Intel® 1210IT Gigabit Ethernet (Support Jumbo Frame)					
Audio	Realtek® High Definition Audio Codec					
Watchdog Timer	Programmable 1 ~ 255 sec					
Storage Device	1 x 2.5" SATA HDD/ SSD, 1 x Compact Flash II up to 64GB, 1 x SD card					
OS	Windows 7/ Windows 8.1 / Windows 10 / Linux™					
<b>I/O Interface</b>						
Series Port	2 x RS-232/422/485 (Expansion: Option 0)					
Display	1x DVI-I					
USB	1 x USB 2.0, 1 x USB 3.0, 2 x USB 2.0 (Expansion: Option 0)					
Ethernet	2 x Gigabit Ethernet					
Others	1 x SMA Antenna hole for WiFi/3G Solution					
Expansion	1 x Half-size Mini-PCIe socket 2 x RS-232/422/485, 1 x RS-232 (Option 1) 1 x Line-out, 1 x RS-232/422/485, 2 x USB 2.0 (Option 2)					
<b>Mechanical</b>						
Dimension(mm)(WxDxH)	314 x 253 x 50.2 mm	343 x 282 x 53.2 mm	425 x 330 x 55.6 mm	437 x 375 x 58.6 mm	480 x 400 x 58.6 mm	476 x 293 x 63.4 mm
Mounting (mm)	VESA Mount 75 x 75, 100 x 100; Panel Mount					
Weight (Kg)(N)	3.5 Kg	4.3 Kg	5.3 Kg	6.8 Kg	7.8 Kg	7 Kg
Weight (Kg)(G)	5.8 Kg	6.2 Kg	8.2 Kg	9.5 Kg	11.2 Kg	10.3 Kg
<b>Power</b>						
Power Supply	DC 12V ~ 24V input with 3-pin terminal block connector					
Consumption (Max)	32W(12V); 35W(24V)	29W(12V); 33W(24V)	30W(12V); 31W(24V)	38W(12V); 38W(24V)	34W(12V); 35W(24V)	42W(12V); 45W(24V)
Consumption (Min)	10W(12V); 11W(24V)	10W(12V); 11W(24V)	10W(12V); 11W(24V)	10W(12V); 11W(24V)	10W(12V); 11W(24V)	21W(12V); 22W(24V)
<b>Environmental</b>						
OP /Storage Temp	-25°C ~ 70°C / -40°C ~ 85°C (20°C ~ 90% non-condensing)					0°C ~ 50°C / -20°C ~ 60°C
Vibration	1.0G(SD/CF/SSD) and 0.5G(HDD) , Power on & 2.16G, Packaged; 5~500Hz, IEC 60068-2-6					
Shock	15G peak acceleration, 11 ms (Power on condition), IEC 60068-2-27					
Drop	Packaged with Carton 96.5cm (1-Corner, 3-Axis, 6-Face), ISTA 2A Standard					
IP Protection	IP65 (Front) / IP20 (Rear), IEC 60529 Edition 2.1 Standard					
Certificate	CE/FCC Class A, UKCA, EN 62368-1, EN 61000-6-2, EN 61000-6-4					

## Cut out Dimension

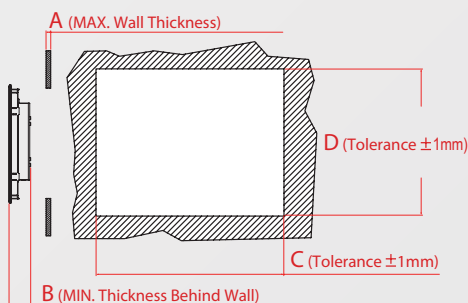

## FUDA2 Single-Touch

	A (mm)	B (mm)	C (mm)	D (mm)	Mounting Kits (pcs)
FUDA2-S1011	<10.7	46.2	297	236	x 8
FUDA2-S1211	<10.9	49.2	326	265	x 12
FUDA2-S1511	<11.3	49.6	409	313	x 16
FUDA2-S1711	<12	52.6	420	358	x 16
FUDA2-S1911	<12	52.6	463	383	x 20
FUDA2-S1830	< 10.7	58.1	452	277	X 16

# FUDA3 Quick Selection Guide

FUDA3 Multi-Touch 10.4" / 12.1" / 15"

Model Name	FUDA3-S1022	FUDA3-S1222	FUDA3-S1522
<b>Display</b>			
LCD Size	10.4"	12.1"	15"
Resolution	XGA 1024 x 768	XGA 1024 x 768	XGA 1024 x 768
Brightness	450 cd/m <sup>2</sup>	600 cd/m <sup>2</sup>	450 cd/m <sup>2</sup>
Contrast Ratio	3000:1	700:1	700:1
Backlight	LED type	LED type	LED type
Touch Screen	Projected Capacitive Multi-Touch (10 points)		
<b>System</b>			
SoC	Intel® Atom™ x7-E3950 (Quad Core, 2M Cache, up to 2.0 GHz)		
Memory	DDR3L SO-DIMM 1866 MHz up to 8 GB		
BIOS	AMI		
Graphics	Intel® HD Graphics 505		
LVDS	Single/ Dual Channel 24-bit		
LAN Chipset	Dual Intel® Gigabit Ethernet Chipset		
Audio	N/A		
Watchdog Timer	Programmable 1 ~ 255 sec		
Storage Device	1 x 2.5" SATA HDD / SSD, 1 x Mini-mSATA		
OS	Windows 10/ Linux™		
<b>I/O Interface</b>			
Series Port	2 x RS-232/422/485 (Expansion : Option 0)		
Display	1 x HDMI		
USB	1 x USB OTG, 2 x USB 3.0	1 x USB OTG, 2 x USB 3.0, 2 x USB 2.0 (Expansion: Option 0)	
Ethernet	2 x Gigabit Ethernet		
Others	1 x SMA Antenna hole for WiFi/LTE Solution		
Expansion	1 x Full-size Mini-PCle socket 1 x Half-size Mini-PCle/Mini-mSATA socket switch by jumper	1 x Full-size Mini-PCle socket 1 x Half-size Mini-PCle/Mini-mSATA socket switch by jumper 2 x RS-232/422/485, 1 x RS-232 (Expansion: option 1)	
<b>Mechanical</b>			
Dimension(mm)(WxDxH)	282 x 238 x 57.3 mm	305 x 260 x 58.2 mm	384 x 310 x 56.6 mm
Mounting (mm)	VESA Mount 75 x 75 & amp; 100 x 100; Panel Mount		
Weight (Kg)(N)	3.5 Kg	3.9 Kg	5.1 Kg
Weight (Kg)(G)	5.8 Kg	6.0 Kg	7.8 Kg
<b>Power</b>			
Power Supply	DC 12 ~ 24V input with 3-pin Terminal Block Connector		
Consumption (Max)	33.5W (12V); 33.6W (24V)	40.9W (12V); 39.4W (24V)	40.5W (12V); 40.2W (24V)
Consumption (Min)	11.8W (12V); 14W (24V)	12W (12V); 12.3W (24V)	11.2W(12V); 12W (24V)
<b>Environmental</b>			
OP /Storage Temp	-25°C ~ 60°C / -40°C ~ 85°C (20 ~ 90% non-condensing)		
Vibration	1.0G (SSD) and 0.5G (HDD) , Power on ; 2.16G, Packaged; 5~500Hz, IEC 60068-2-6		
Shock	15G peak acceleration, 11 ms (Power on condition), IEC 60068-2-27		
Drop	Package with Carton from 96.5 cm (1-Corner, 3-Axis, 6-Face), ISTA 2A Standard		
IP Protection	IP65 (Front) / IP20 (Rear), IEC 60529 Edition 2.1 Standard		
Certificate	CE/FCC Class A, UKCA, EN 62368-1, EN 61000-6-2 , EN 61000-6-4		

## Cut out Dimension

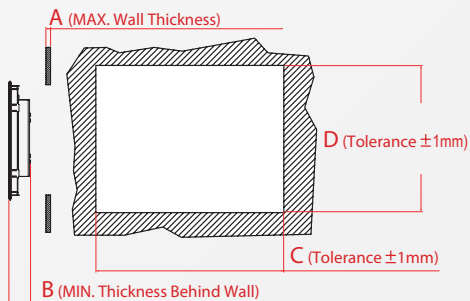

## FUDA3 Multi-Touch

	A (mm)	B (mm)	C (mm)	D (mm)	Mounting Kits (pcs)
FUDA3-S1022	<10	52.5	265	222	X 8
FUDA3-S1222	<10	52.4	289	244	X 8
FUDA3-S1522	<7	50.6	367	293	X 14



# FUDA3 Quick Selection Guide

FUDA3 Single-Touch 10.4" / 12.1" / 15"

Model Name	FUDA3-S1012	FUDA3-S1212	FUDA3-S1512
<b>Display</b>			
LCD Size	10.4"	12.1"	15"
Resolution	XGA 1024 x 768	XGA 1024 x 768	XGA 1024 x 768
Brightness	450 cd/m <sup>2</sup>	600 cd/m <sup>2</sup>	450 cd/m <sup>2</sup>
Contrast Ratio	3000:1	700:1	700:1
Backlight	LED type	LED type	LED type
Touch Screen	5-Wire Resistive Single Touch		
<b>System</b>			
SoC	Intel® Atom™ x7-E3950 (Quad Core, 2M Cache, up to 2.0 GHz)		
Memory	DDR3L SO-DIMM 1866 MHz up to 8 GB		
BIOS	AMI		
Graphics	Intel® HD Graphics 505		
LVDS	Single/ Dual Channel 24-bit		
LAN Chipset	Dual Intel® Gigabit Ethernet Chipset		
Audio	N/A		
Watchdog Timer	Programmable 1 ~ 255 sec		
Storage Device	1 x 2.5" SATA HDD / SSD, 1 x Mini-mSATA		
OS	Windows 10/ Linux™		
<b>I/O Interface</b>			
Series Port	2 x RS-232/422/485 (Expansion : Option 0)		
Display	1 x HDMI		
USB	1 x USB OTG, 2 x USB 3.0, 2 x USB 2.0 (Expansion: Option 0)		
Ethernet	2 x Gigabit Ethernet		
Others	1 x SMA Antenna hole for WiFi/LTE Solution		
Expansion	1 x Full-size Mini-PCIe socket 1 x Half-size Mini-PCIe/Mini-mSATA socket switch by jumper 2 x RS-232/422/485, 1 x RS-232 (Expansion: option 1)		
<b>Mechanical</b>			
Dimension(mm)(WxDxH)	314 x 253 x 50.2 mm	343 x 282 x 53.2 mm	425 x 330 x 55.6 mm
Mounting (mm)	VESA Mount 75 x 75 & amp; 100 x 100; Panel Mount		
Weight (Kg)(N)	3.5 Kg	4.3 Kg	5.3 Kg
Weight (Kg)(G)	5.8 Kg	6.2 Kg	8.2 Kg
<b>Power</b>			
Power Supply	DC 12 ~ 24V input with 3-pin Terminal Block Connector		
Consumption (Max)	33.5W (12V); 33.6W (24V)	40.9W (12V); 39.4W (24V)	40.5W (12V); 40.2W (24V)
Consumption (Min)	11.8W (12V); 14W (24V)	12W (12V); 12.3W (24V)	11.2W(12V); 12W (24V)
<b>Environmental</b>			
OP /Storage Temp	-25°C ~ 60°C / -40°C ~ 85°C (20 ~ 90% non-condensing)		
Vibration	1.0G (SSD) and 0.5G (HDD) , Power on ; 2.16G, Packaged; 5~500Hz, IEC 60068-2-6		
Shock	15G peak acceleration, 11 ms (Power on condition), IEC 60068-2-27		
Drop	Package with Carton from 96.5 cm (1-Corner, 3-Axis, 6-Face), ISTA 2A Standard		
IP Protection	IP65 (Front) / IP20 (Rear), IEC 60529 Edition 2.1 Standard		
Certificate	CE/FCC Class A, UKCA, EN 62368-1, EN 61000-6-2 , EN 61000-6-4		

## Cut out Dimension

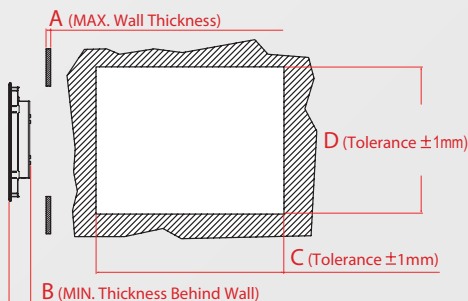

## FUDA3 Single-Touch

	A (mm)	B (mm)	C (mm)	D (mm)	Mounting Kits (pcs)
FUDA3-S1012	<10.7	46.2	297	236	x 8
FUDA3-S1212	<10.9	49.2	326	265	x 12
FUDA3-S1512	<11.3	49.6	409	313	x 16

# COMBO Quick Selection Guide

## COMBO Multi-Touch 10.1"

Model Name		COMBO-S1020
<b>Display</b>		
LCD Size		10.1" (16:9)
Resolution		WXGA 1280 x 800
Brightness		300 cd/m <sup>2</sup>
Contrast Ratio		1300 : 1
Backlight		LED type
Touch Screen		Projected Capacitive Multi-Touch
<b>System</b>		
SoC		Freescale™ i.MX6 Solo/Quad-core Processor Cortex™ A9
Memory		512MB/2GB DDR3 1066 Memory Chip on Board
BIOS		N/A
Graphics		Freescale™ i.MX6 Graphic Engine
LVDS		Single/Dual Channel 24-bit
LAN Chipset		Single Atheros AR8035 Ethernet PHY
Audio		SGTL 5000 Audio Codec
Watchdog Timer		Control by Software
Storage Device		8GB eMMC on board, 1x SD card, 1x half-size mSATA socket (Quad core sku support only)
OS		Yocto Linux™ 4.1.15 + QT 5.6.1 / Android 6.0
<b>I/O Interface</b>		
Series Port		1 x RS-232/422/485
Display		1 x HDMI input, 1 x HDMI output
USB		2 x USB 2.0, 1 x USB OTG
Ethernet		1 x Gigabit Ethernet
Others		1 x CAN 2.0B (DB9) 1 x SMA Antenna hole for WiFi, 3G, 4G LTE Solution
Expansion		1x Full-size Mini-PCIe socket
<b>Mechanical</b>		
Dimension(mm)(WxDxH)		286 x 196 x 48.6 mm
Mounting		VESA Mount 50 x 25, 75 x 75 ; Panel Mount
Weight (Kg)(N)		1.6 Kg
Weight (Kg)(G)		3.4 Kg
<b>Power</b>		
Power Supply		DC 12V ~ 24V input with 3-pin terminal block connector
Consumption (Max)		25 W
Consumption (Min)		6.2 W
<b>Environmental</b>		
OP /Storage Temp		-20 ~ 60 °C / -30 ~ 80°C (20~90% non-condensing)
Vibration		1.0G (SD/eMMC), Power on & 2.16G, Packaged; 5~500Hz, IEC 60068-2-6
Shock		15G peak acceleration, 11 ms (Power on condition), IEC 60068-2-27
Drop		Package with Carton from 96.5 cm (1-Corner, 3-Axis, 6-Face), ISTA 2A Standard
IP Protection		IP65 (Front) / IP20 (Rear), IEC 60529 Edition 2.1 Standard
Certificate		CE/FCC Class A

### Cut out Dimension

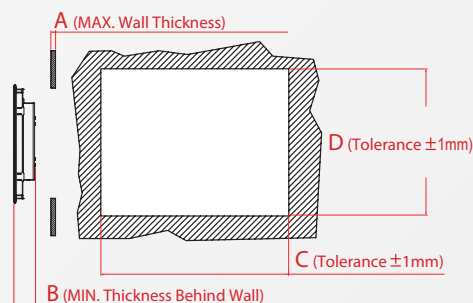

### COMBO Multi-Touch

	A (mm)	B (mm)	C (mm)	D (mm)	Mounting Kits (pcs)
COMBO-S1020	< 8.6	45	270	180	x 8

# Further Contact

**Completed Technical Service** - In order to ensure that customers can get the right and speedy service from Portwell, we do offer the following services to meet your needs.



## Logistics Service

It is not only for the scalable or world-grade customers, we offer the service to our partners who need the world-wide delivery to save time and expense.



## Consulting Service

Our engineering experts provide a free service to discuss with you the projects or technologies that you need in a short period of time. Please visit Portwell web and click the button, then the on-line service will appear for you.



## Product Service

We have the experienced product managers who can help you to get the right products in our list and also the related information to complete your solution.



## Manufacturing Service

Portwell has the most advanced manufacturing facilities to produce the quality product for your application or business. Please pay a visit to our Portwell engine, you will know how best that we can do for you.



## Design Service

If our existing products cannot meet your requirements, a customized design service can be initiated to build the exact products that you demand.

Both Portwell RDC & SIC are set for the completed service to our customers & Partners. Your any requirements or technical issues are welcome to contact us for further solution. Our service can be arranged in the following ways.

## Web Service

Portwell already set up the contact for our technology service on the air. Please just visit our web on the internet and left the message for further contact by our people. Besides, you also can get the on-line consulting service via Skype or the phone if the immediate service is needed.

## Extended Visits to PE

Some idea or issue is not easy to have the solution within short period of time. Portwell has the necessary facility and dormitory for customers or partners who need to stay with us for a period of time. Please contact us and our service people will give you the message for it.

## Direct Contact

Portwell welcomes our customers to visit our Laboratory for the regulation test or design service. We believe that it is the fastest way to solve your questions and achieve the right solution. Just call or mail us; you will have the right service immediately.



## Global Service (Telephone)

In addition, you can get immediate support via telephone. Check the web site for phone numbers.  
<https://www.portwell.com.tw/portwell-worldwide/>



## Technical Request

For technical support, you could reach our technical request website as follows  
<https://www.portwell.com.tw/support-center/technical-request/>





# Smart Automation Future

[www.portwell.com.tw](http://www.portwell.com.tw)



## Portwell, Inc. Headquarters

No. 242, Bo'AI St., Shu-Lin Dist,  
New Taipei City 238, Taiwan  
Tel: +886-2-7731-8888  
Fax: +886-2-7731-9888  
E-mail: [info@portwell.com.tw](mailto:info@portwell.com.tw)  
[www.portwell.com.tw](http://www.portwell.com.tw)

### Americas

#### American Portwell (Fremont, CA)

44200 Christy St., Fremont, CA 94538, USA  
Tel: +1-510-403-3399  
Fax: +1-510-403-3184  
E-mail: [info@portwell.com](mailto:info@portwell.com)  
[www.portwell.com](http://www.portwell.com)

### Japan

#### Portwell Japan, Inc. (Tokyo)

〒112-0011 4-27-10, Sengoku, Bunkyo-ku,  
Tokyo, Japan  
Tel: +81-3-6902-9225  
Fax: +81-3-6902-9226  
E-mail: [info@portwell.co.jp](mailto:info@portwell.co.jp)  
[www.portwell.co.jp](http://www.portwell.co.jp)

#### Portwell Japan, Inc. (Osaka)

〒532-0004 Ste.501 Nippo Shin-osaka Dai-2  
Bldg, 1-8-33 Nishi-Miyahara, Yodogawa-ku  
Osaka Japan  
Tel: +81-6-4807-7721  
Fax: +81-6-4807-7720  
E-mail: [info@portwell.co.jp](mailto:info@portwell.co.jp)  
[www.portwell.co.jp](http://www.portwell.co.jp)

### Europe

#### European Portwell

Schillingweg 3, 2153 PL  
Nieuw Vennepe, The Netherlands  
Tel: +31-252-620790  
E-mail: [info@portwell.eu](mailto:info@portwell.eu)  
[www.portwell.eu](http://www.portwell.eu)

#### KIOSK Embedded Systems GmbH

Am Technologiepark 8-10,  
D-82229 Seefeld  
Tel: +49-8152-3962-500  
E-mail: [info@portwell.eu](mailto:info@portwell.eu)  
[www.portwell.de](http://www.portwell.de)

#### Portwell UK Ltd.

Office TH2  
Trident House, Trident Park Basil  
Hill Road, Didcot, OX11 7HJ, UK  
Tel: +44(0)1235-750-760  
Fax: +44(0)1235-750-761  
E-mail: [info@portwell.eu](mailto:info@portwell.eu)  
[www.portwell.eu](http://www.portwell.eu)

### China

#### Shanghai Portwell

(201612), Room 1303-1, Building 33, No.258,  
Xinhuan Highway, Songjiang District,  
Shanghai  
Tel: +86-21-5771-2505  
Fax: +86-21-5772-2965  
E-mail: [info@portwell.com.cn](mailto:info@portwell.com.cn)  
[www.portwell.com.cn](http://www.portwell.com.cn)

### Korea

#### Portwell Korea, Inc.

O-BIZ Tower 1901, No.126,  
Beolmal-ro, Dongan-gu, Anyang-si,  
Gyeonggi-do, Korea, 431-060  
Tel: +82-31-450-3043  
Fax: +82-31-450-3044  
E-mail: [info@portwell.co.kr](mailto:info@portwell.co.kr)  
[www.portwell.co.kr](http://www.portwell.co.kr)

### India

#### Portwell India Technology Private Limited.

3rd Floor, Jeet Dynasty, Old Madras Rd,  
next to Gopalan Signature Mall, Nagavarapalya,  
Benniganahalli, Bengaluru, Karnataka 560093,  
India  
Tel: +91-80-4168-4255  
E-mail: [enquiry@portwell.in](mailto:enquiry@portwell.in)  
[www.portwell.in](http://www.portwell.in)